

1484 OPERATION INSTRUCTION

Features:

- Time Display(12 / 24H format selectable)
- Week, Date
- Daily Alarm and Chime hourly
- Stopwatch function from 00'00''00-29'59''59
- Second time function
- EL backlight

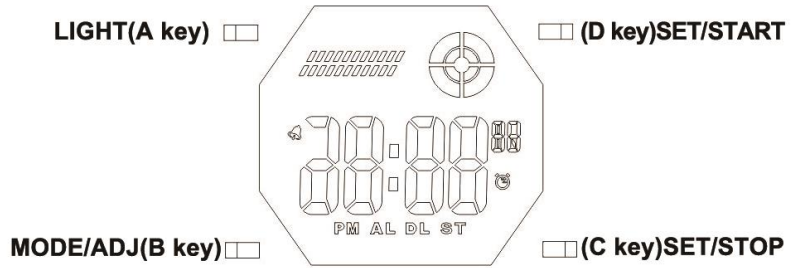

Mode Convert:

- In any Mode , press A key for EL backlight ON 3s
- Press B key to convert MODE as following :

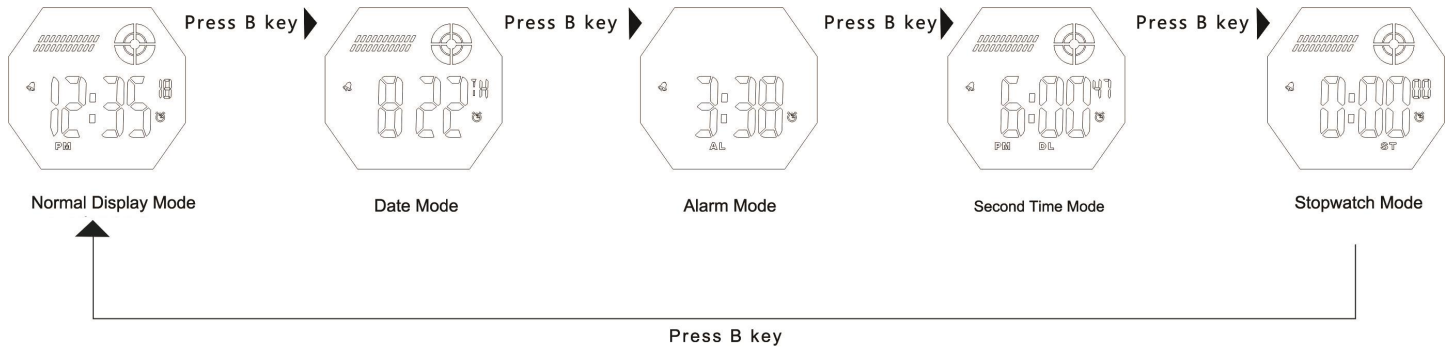

Time Setting:

- In normal Mode, press C/D Key for 2s, the "Hour" is flashing, press C/D key to select as following sequence: Hour, Minute, 12/24H format flash.
- Press B key to adjust the flashing item.
- Press C/D key to exit.

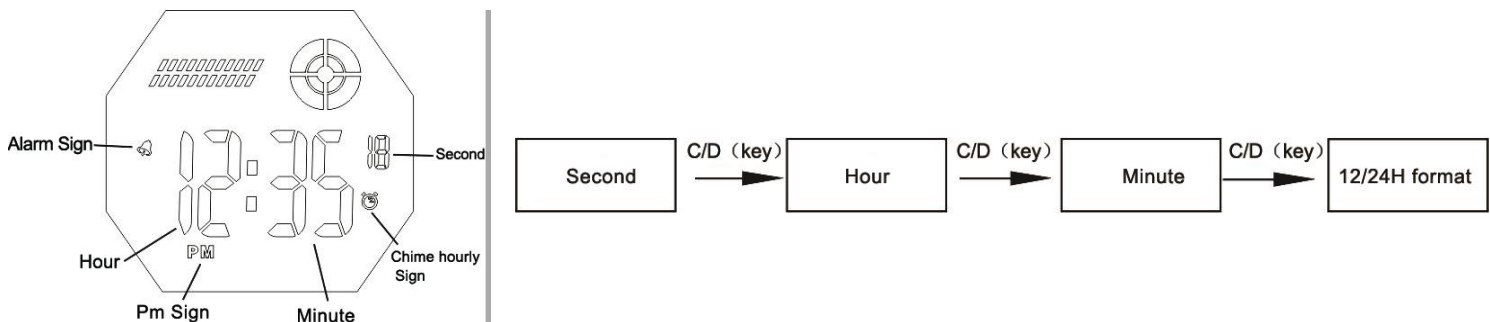

Date Setting:

In normal display Mode, press B key once enter into Date Mode

- Press and hold C/D key for 2s, the “Month” is flashing, press C/D key again, “Date”, “Week” is flashing, press B to adjust item.
- After adjustment, press C/D key to finish the setting.

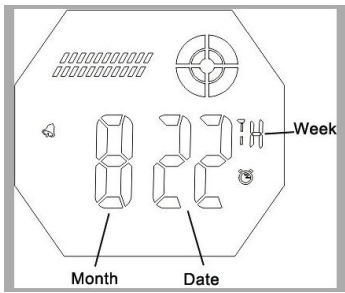

Alarm Setting:

- In normal display Mode, press B key twice enter into Alarm Mode(AL symbol display)
- Press and Hold C/D key for 2s, the Hours will flash. Press C/D key once, Ten digits flashes, press it again, digital flashes, Press B key to adjust the flashing item.
- Press C/D key the “Alarm” and “Hourly Chime” will flash, then press B key once, “Alarm” and “Hourly Chime” are displaying for Off.
- Press B twice then “Alarm” On, Press B three times “Hourly Chime” On, Press B four times, the “Alarm” and “Hourly Chime” all displaying for On.
- After setting Alarm and press C/D once to finish the setting.

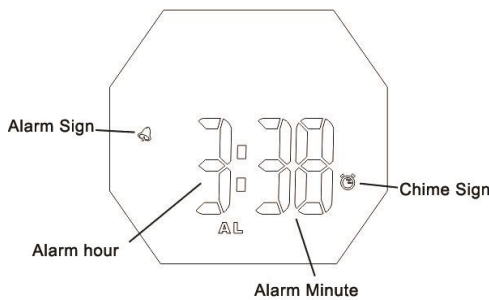

Second Time Setting:

- In normal Mode, press B key three times to enter into Second Time Mode(DL symbol display).
- Press and hold C/D key for 2s, and “Hours” will flash.
- Press C/D key to select as following sequence: Minute, 12/24H format flash.
- Press B key to adjust the flashing item.
- After setting Time, press C/D once to finish the setting.

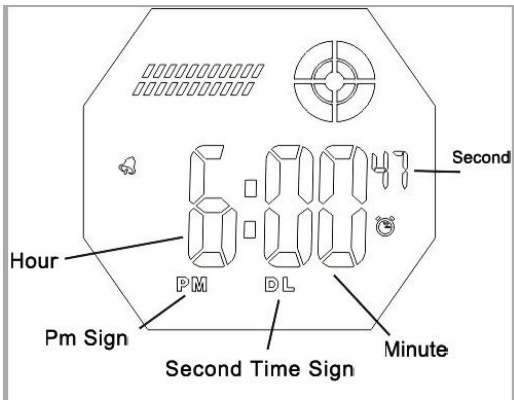

Chronograph Functions:

- In normal Mode, press B key four times to enter into Stopwatch Mode(ST symbol display).
- Press C/D key once to start running, press C/D twice stop running.
- When stop and press and Hold C/D key for 2s to zero.

