

www.neilpryde.com

RS:X CONVERTIBLE
ASSEMBLY MANUAL



WINDFOIL

NEILPRYDE

RS:X CONVERTIBLE
ASSEMBLY MANUAL
WINDFOIL

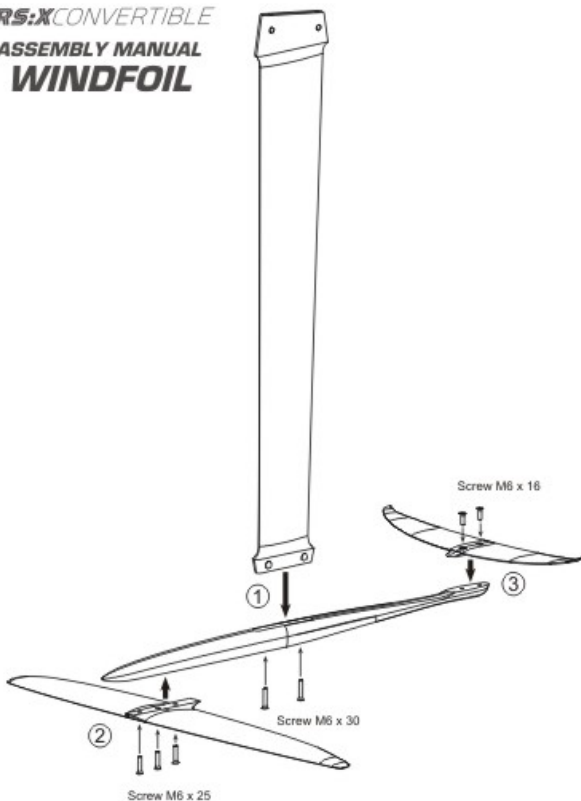

RS:X CONVERTIBLE
WINDFOIL



Assembly Notice

- ① Prepare a clean area on the floor to set the mast inside the fuselage : Embed the bottom mast inside the fuselage and push upon the mast to connect the two parts. Tighten the 2 screws M6 x 30 (The longer ones).
- ② Connect the Front wing to the fuselage by tightening the 3 screws M6 x 25 (The medium ones).
- ③ Connect the rear wing to the fuselage by tightening The 2 screws M6 X 16 (the shorter ones).
- ④ Connect the whole assembled foil to your Board by using M6 screws with correct length.

Our recommendations

To avoid corrosion of stainless insert with stainless screws, we recomand you to fill in th insert with a lubricant (WD-40 or Wax) before tightening the screws.