

The Slasher (with excavator mount) is a slashing attachment for excavators which can be used for the effective cutting and clearing of grass and low ground shrubbery.

## Features:

- Heavy duty excavator mount
- Twin blade, dual rotation, single cutting bar
- Available widths: 1000mm, 1250mm, 1500mm
- Chain curtain for debris suppression - New legislation
- Adjustable cutting height between 40 and 140mm
- Heavy duty construction - built for Australian conditions
- Also available for: mini loaders, skid steer loaders, tractors
- Rounded side skids for smoother manoeuvrability over uneven terrain



## Accessories:

Comes complete with hoses, couplers and hitch to suit your excavator. Optional multifit or side shift frame available to suit skid steer loaders

## Ideal Use:

Landscaping, agriculture, roadway maintenance, general slashing, park maintenance

## Machine Suitability:

Available to fit excavators with flows upto 100lpm and standard skid steer loaders

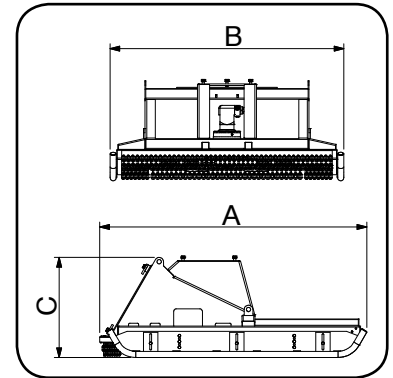

Specifications	1000mm	1250mm	1500mm
Machine Suitability	Excavator Up to 2T	Excavator Up to 5T	Excavator Up to 8T
Weight	215 Kg	295 Kg	395 Kg (No mount)
Length	1373 mm	1700 mm	1860 mm
Width (Overall)	1193 mm	1443 mm	1630 mm
Height	579 mm	600 mm	635 mm
Motor Size	6 Cubic Inch EATON Motor	4.9 Cubic Inch EATON Motor	4.9 Cubic Inch EATON Bell Motor
Rec. Flow	30- 60 lpm	50 - 100 lpm	45 - 100 lpm
Max Pressure	240 bar	240 bar	240 bar



**Contact your local professional dealer or contact Digga direct**

THE BEST DOWNUNDER

# DIGGA

**QLD, NT**

4 Octal Street  
Yatala QLD 4207  
Ph: (07) 3807 3330

**DIGGA NSW, ACT**

Unit 2, 36 Bluett Drive  
Smeaton Grange NSW 2567  
Ph: (02) 4647 1400

**DIGGA VIC, SA, TAS**

27 Metcalf Street  
South Dandenong VIC 3175  
Ph: (03) 9706 6171

**DIGGA WA**

6/15 Yampi Way  
Willeton WA 6155  
Ph: (08) 9457 1544

Email: [info@digga.com](mailto:info@digga.com) Web: [www.digga.com](http://www.digga.com)

