

CLASSIC FIELD
Wide Hex Twist

1/8" – 3/16" GROUT LINE

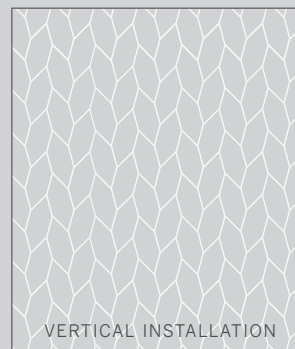
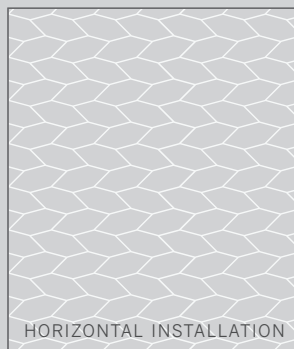

INSTALLATION: INDIVIDUAL TILE

- 1 SELECT A HORIZONTAL OR VERTICAL ORIENTATION AND DETERMINE YOUR PRIMARY GRID LINES. IT IS IMPORTANT TO KEEP THE PRIMARY GRID LINES STRAIGHT AND ALIGNED THROUGHOUT THE INSTALLATION, PARTICULARLY WHEN INSTALLING PIECE BY PIECE.

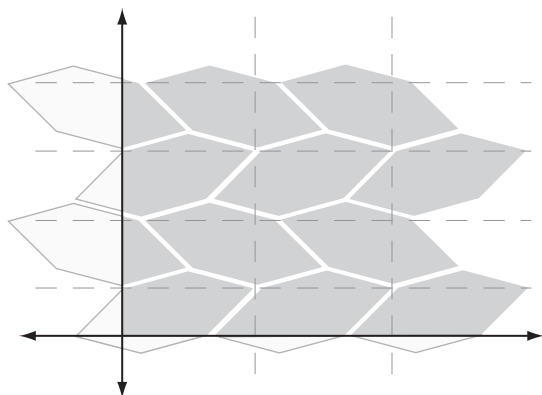

- 2 TO CREATE A FLUSH LINE AT THE INSTALLATION'S EDGE, SOME TILES WILL NEED TO BE INDIVIDUALLY CUT. THE CUT POINTS SHOULD ALL BE ALIGNED.

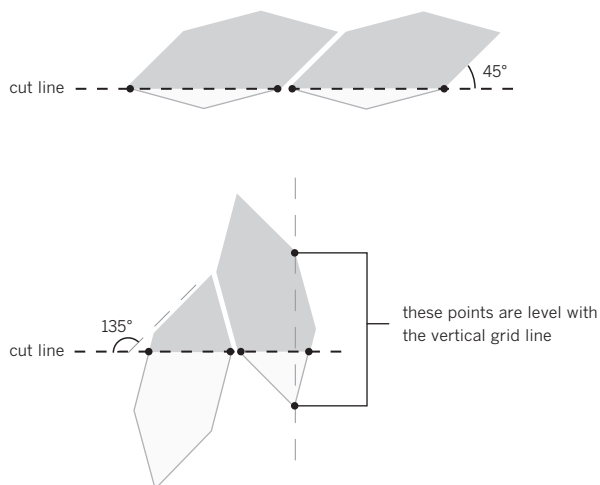

INSTALLATION: FACE-MOUNTED MODULE

- 1 SELECT A HORIZONTAL OR VERTICAL ORIENTATION AND DETERMINE YOUR PRIMARY GRID LINES. IT IS IMPORTANT TO KEEP THE PRIMARY GRID LINES STRAIGHT & ALIGNED THROUGHOUT THE INSTALLATION.

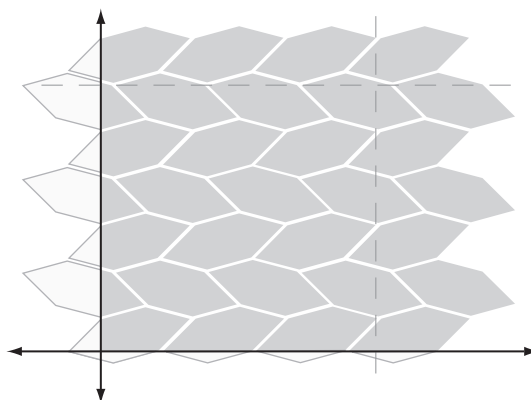

- 2 LAY OUT MODULES TO CONSTRUCT YOUR PATTERN. CUT THROUGH MOUNTING TAPE TO MAKE ADJUSTMENTS AS YOU GO.
- 3 CORRECTIONS OF INDIVIDUAL TILES WITHIN FACE-MOUNTED SHEETS MAY BE NECESSARY.

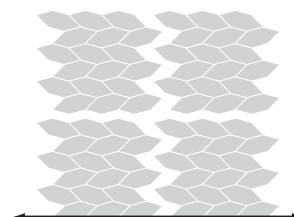

1-color pattern

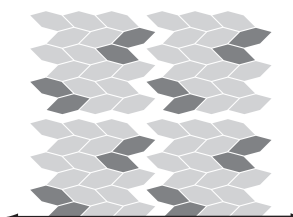

2-color pattern

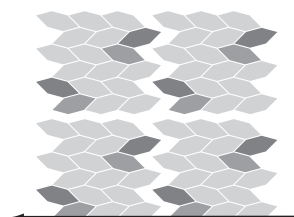

3-color pattern

CLASSIC FIELD
Wide Hex Stack

1/8" – 3/16" GROUT LINE

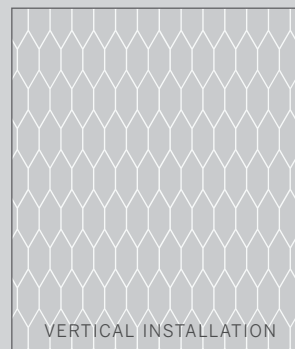
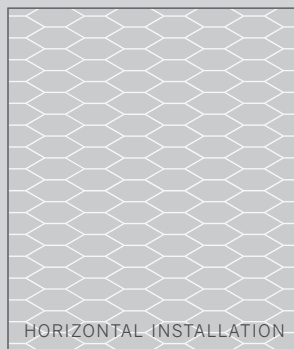

INSTALLATION: INDIVIDUAL TILE

- 1 SELECT A HORIZONTAL OR VERTICAL ORIENTATION AND DETERMINE YOUR PRIMARY GRID LINES. IT IS IMPORTANT TO KEEP THE PRIMARY GRID LINES STRAIGHT AND ALIGNED THROUGHOUT THE INSTALLATION, PARTICULARLY WHEN INSTALLING PIECE BY PIECE.

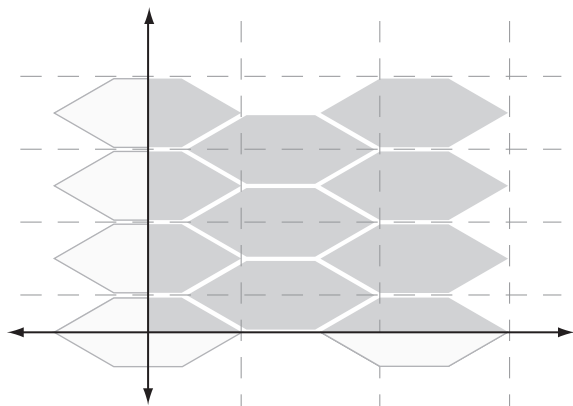

- 2 TO CREATE A FLUSH LINE AT THE INSTALLATION'S EDGE, SOME TILES WILL NEED TO BE INDIVIDUALLY CUT. THE CUT POINTS SHOULD ALL BE ALIGNED.

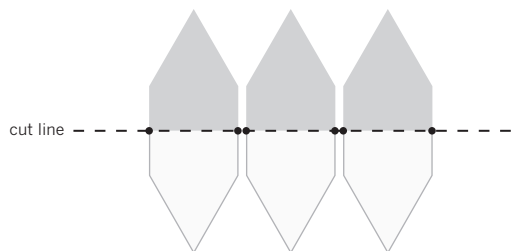
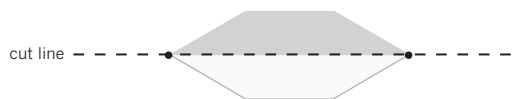

INSTALLATION: FACE-MOUNTED MODULE

- 1 SELECT A HORIZONTAL OR VERTICAL ORIENTATION AND DETERMINE YOUR PRIMARY GRID LINES. IT IS IMPORTANT TO KEEP THE PRIMARY GRID LINES STRAIGHT & ALIGNED THROUGHOUT THE INSTALLATION.

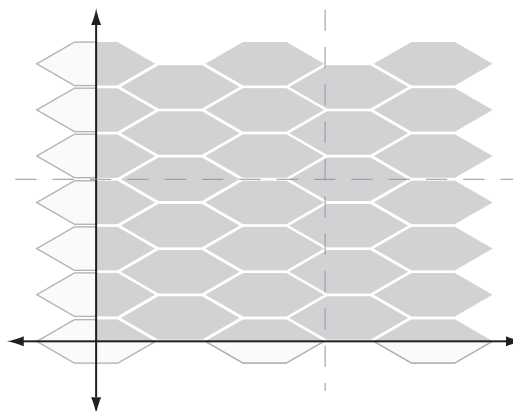

- 2 LAY OUT MODULES TO CONSTRUCT YOUR PATTERN. CUT THROUGH MOUNTING TAPE TO MAKE ADJUSTMENTS AS YOU GO.

- 3 CORRECTIONS OF INDIVIDUAL TILES WITHIN FACE-MOUNTED SHEETS MAY BE NECESSARY.

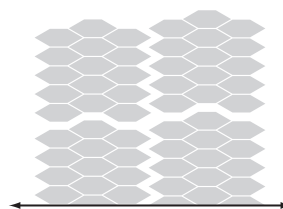
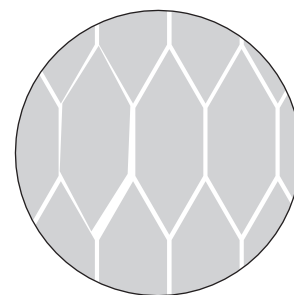

CLASSIC FIELD
Little Diamond Mix

1/8" – 3/16" GROUT LINE

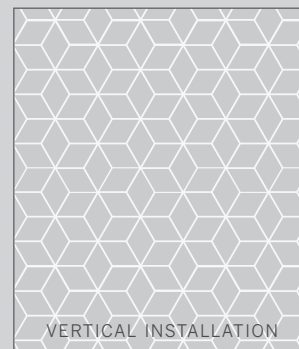
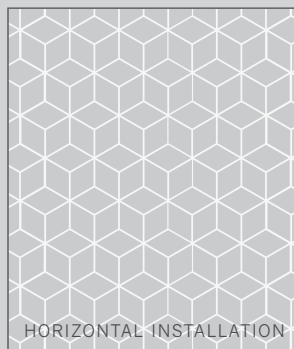

INSTALLATION: INDIVIDUAL TILE

- 1 SELECT A HORIZONTAL OR VERTICAL ORIENTATION AND DETERMINE YOUR PRIMARY GRID LINES. IT IS IMPORTANT TO KEEP THE PRIMARY GRID LINES STRAIGHT AND ALIGNED THROUGHOUT THE INSTALLATION, PARTICULARLY WHEN INSTALLING PIECE BY PIECE.

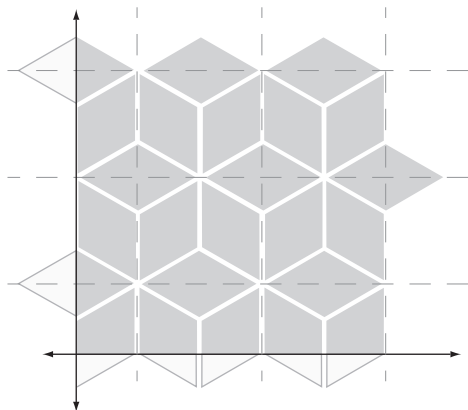

- 2 TO CREATE A FLUSH LINE AT THE INSTALLATION'S EDGE, SOME TILES WILL NEED TO BE INDIVIDUALLY CUT. THE CUT POINTS SHOULD ALL BE ALIGNED.

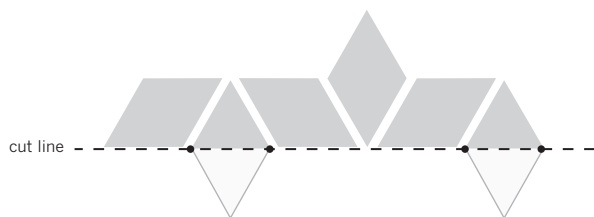
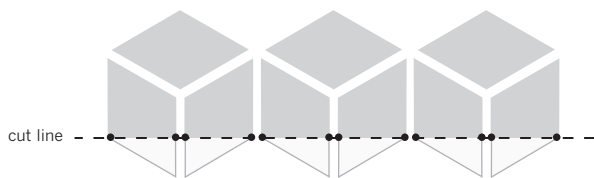

INSTALLATION: FACE-MOUNTED MODULE

- 1 SELECT A HORIZONTAL OR VERTICAL ORIENTATION AND DETERMINE YOUR PRIMARY GRID LINES. IT IS IMPORTANT TO KEEP THE PRIMARY GRID LINES STRAIGHT & ALIGNED THROUGHOUT THE INSTALLATION.

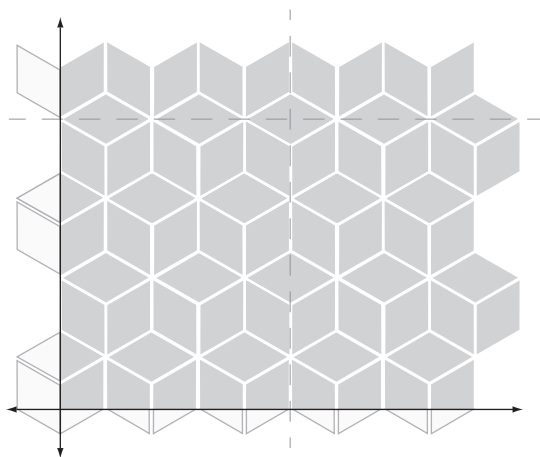

- 2 LAY OUT MODULES TO CONSTRUCT YOUR PATTERN. CUT THROUGH MOUNTING TAPE TO MAKE ADJUSTMENTS AS YOU GO.

- 3 CORRECTIONS OF INDIVIDUAL TILES WITHIN FACE-MOUNTED SHEETS MAY BE NECESSARY.

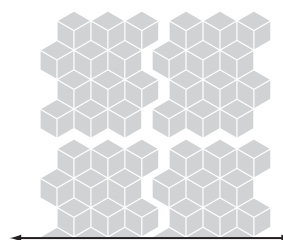

1-color pattern

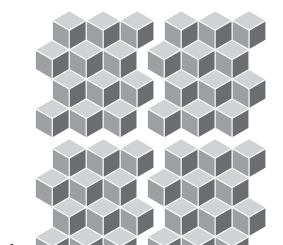

3-color pattern

CLASSIC FIELD
Half Hex Mix

1/8" – 3/16" GROUT LINE

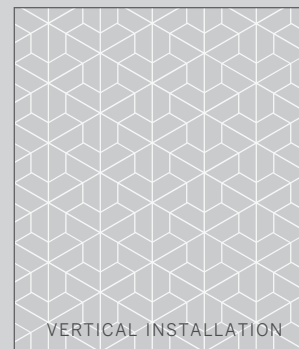
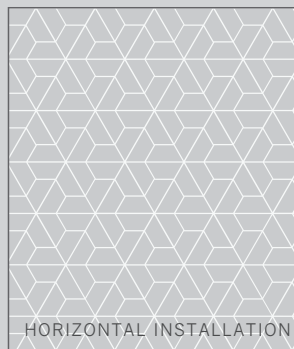

INSTALLATION: INDIVIDUAL TILE

- 1 SELECT A HORIZONTAL OR VERTICAL ORIENTATION AND DETERMINE YOUR PRIMARY GROUT LINES. IT IS IMPORTANT TO KEEP THE PRIMARY GROUT LINES STRAIGHT AND ALIGNED THROUGHOUT THE INSTALLATION, PARTICULARLY WHEN INSTALLING PIECE BY PIECE.

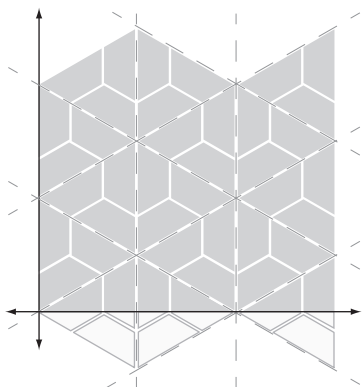

- 2 LAY OUT IN TRIANGULAR GROUPS OF 3 TILES. THERE ARE TWO DIFFERENT CONFIGURATIONS, AS INDICATED BY NUMBERS 1 & 2. NOTE HOW THE CORNERS OF THE TILES MEET.

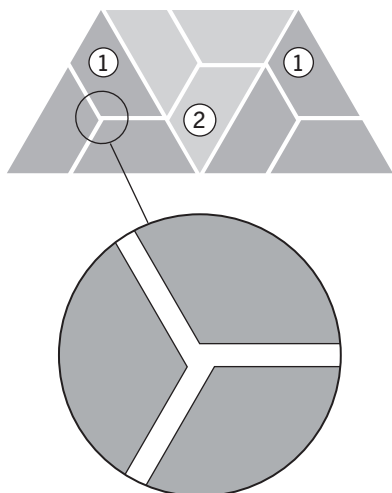

INSTALLATION: FACE-MOUNTED MODULE

- 1 SELECT A HORIZONTAL OR VERTICAL ORIENTATION AND DETERMINE YOUR PRIMARY GROUT LINES. IT IS IMPORTANT TO KEEP THE PRIMARY GROUT LINES STRAIGHT & ALIGNED THROUGHOUT THE INSTALLATION.

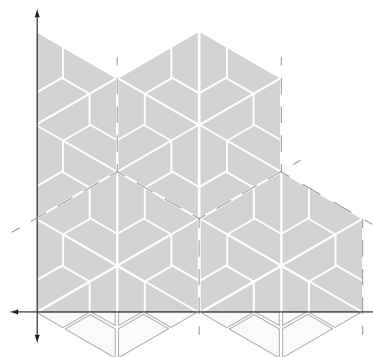

- 2 LAY OUT MODULES TO CONSTRUCT YOUR PATTERN. CUT THROUGH MOUNTING TAPE TO MAKE ADJUSTMENTS AS YOU GO.

- 3 CORRECTIONS OF INDIVIDUAL TILES WITHIN FACE-MOUNTED SHEETS MAY BE NECESSARY.

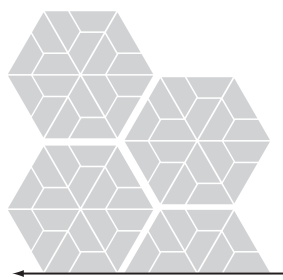

1-color pattern

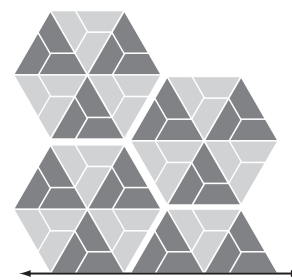

2-color pattern

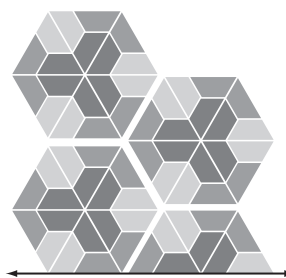

3-color pattern (a)

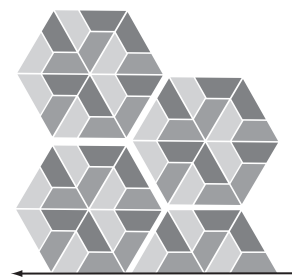

3-color pattern (b)

CLASSIC FIELD
Half Hex Stack

1/8" – 3/16" GROUT LINE

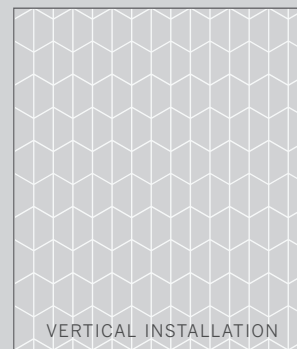
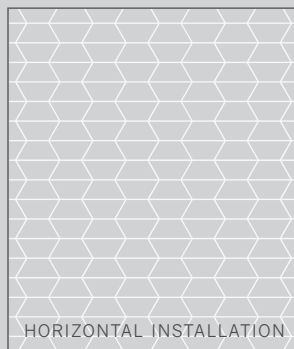

INSTALLATION: INDIVIDUAL TILE

- 1 SELECT A HORIZONTAL OR VERTICAL ORIENTATION AND DETERMINE YOUR PRIMARY GROUT LINES. IT IS IMPORTANT TO KEEP THE PRIMARY GROUT LINES STRAIGHT AND ALIGNED THROUGHOUT THE INSTALLATION, PARTICULARLY WHEN INSTALLING PIECE BY PIECE.

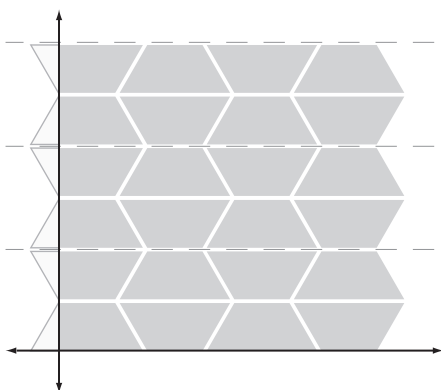

- 2 TO CREATE A FLUSH LINE AT THE INSTALLATION'S EDGE, SOME TILES WILL NEED TO BE INDIVIDUALLY CUT. THE CUT POINTS SHOULD ALL BE ALIGNED.

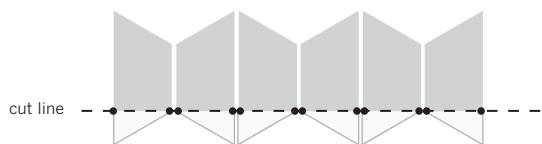

INSTALLATION: FACE-MOUNTED MODULE

- 1 SELECT A HORIZONTAL OR VERTICAL ORIENTATION AND DETERMINE YOUR PRIMARY GRID LINES. IT IS IMPORTANT TO KEEP THE PRIMARY GRID LINES STRAIGHT & ALIGNED THROUGHOUT THE INSTALLATION.

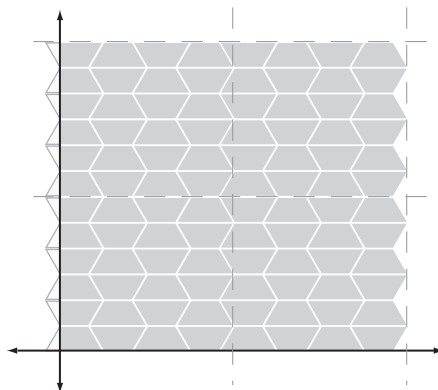

- 2 LAY OUT MODULES TO CONSTRUCT YOUR PATTERN. CUT THROUGH MOUNTING TAPE TO MAKE ADJUSTMENTS AS YOU GO.

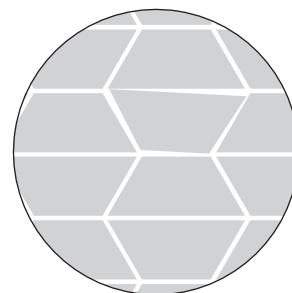

- 3 CORRECTIONS OF INDIVIDUAL TILES WITHIN FACE-MOUNTED SHEETS MAY BE NECESSARY.

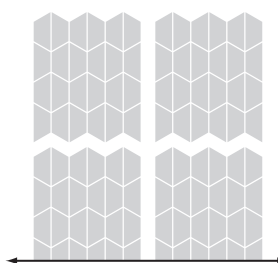

1-color pattern

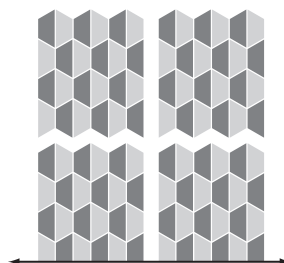

2-color pattern

CLASSIC FIELD
Half Hex Diamond Stack

1/8" – 3/16" GROUT LINE

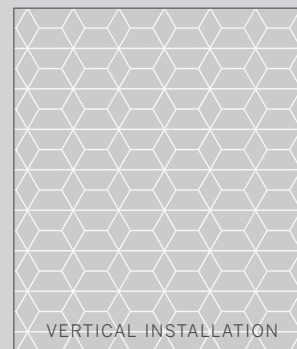

INSTALLATION: INDIVIDUAL TILE

- 1 SELECT A HORIZONTAL OR VERTICAL ORIENTATION AND DETERMINE YOUR PRIMARY GRID LINES. IT IS IMPORTANT TO KEEP THE PRIMARY GRID LINES STRAIGHT AND ALIGNED THROUGHOUT THE INSTALLATION, PARTICULARLY WHEN INSTALLING PIECE BY PIECE.

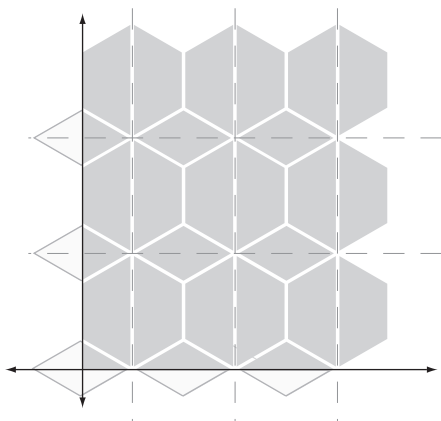

- 2 TO CREATE A FLUSH LINE AT THE INSTALLATION'S EDGE, SOME TILES WILL NEED TO BE INDIVIDUALLY CUT. THE CUT POINTS SHOULD ALL BE ALIGNED.

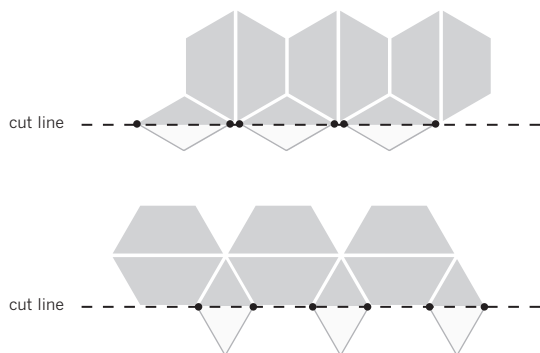

INSTALLATION: FACE-MOUNTED MODULE

- 1 SELECT A HORIZONTAL OR VERTICAL ORIENTATION AND DETERMINE YOUR PRIMARY GROUT LINES. IT IS IMPORTANT TO KEEP THE PRIMARY GROUT LINES STRAIGHT & ALIGNED THROUGHOUT THE INSTALLATION.

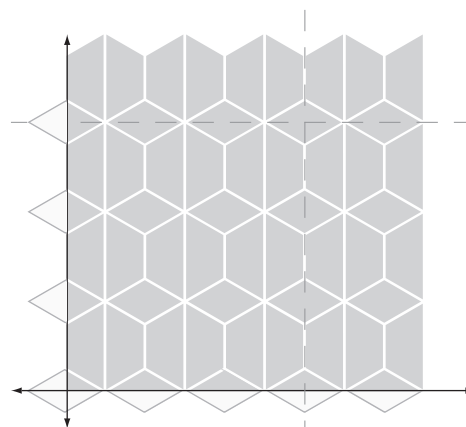

- 2 LAY OUT MODULES TO CONSTRUCT YOUR PATTERN. CUT THROUGH MOUNTING TAPE TO MAKE ADJUSTMENTS AS YOU GO.

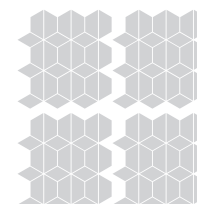

- 3 CORRECTIONS OF INDIVIDUAL TILES WITHIN FACE-MOUNTED SHEETS MAY BE NECESSARY.

1-color pattern

CLASSIC FIELD
Half Hex Wave

1/8" – 3/16" GROUT LINE

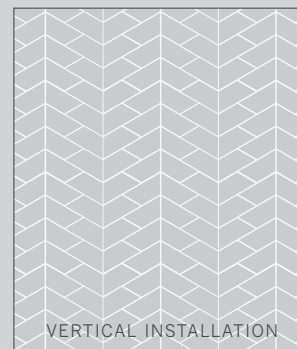
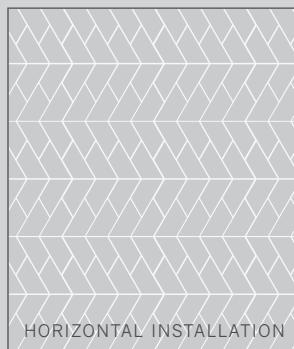

INSTALLATION: INDIVIDUAL TILE

- 1 SELECT A HORIZONTAL OR VERTICAL ORIENTATION AND DETERMINE YOUR PRIMARY GROUT LINES. IT IS IMPORTANT TO KEEP THE PRIMARY GROUT LINES STRAIGHT AND ALIGNED THROUGHOUT THE INSTALLATION, PARTICULARLY WHEN INSTALLING PIECE BY PIECE.

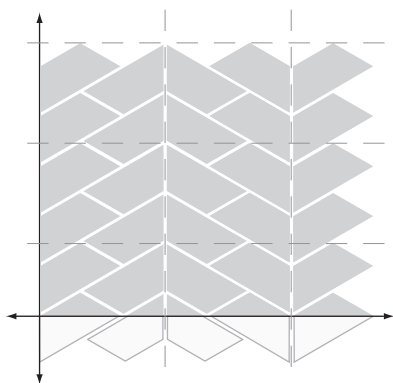

- 2 TO CREATE A FLUSH LINE AT THE INSTALLATION'S EDGE, SOME TILES WILL NEED TO BE INDIVIDUALLY CUT. THE CUT POINTS SHOULD ALL BE ALIGNED.

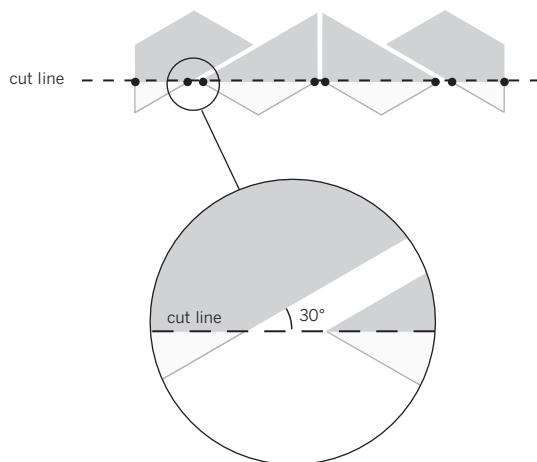

INSTALLATION: FACE-MOUNTED MODULE

- 1 SELECT A HORIZONTAL OR VERTICAL ORIENTATION AND DETERMINE YOUR PRIMARY GROUT LINES. IT IS IMPORTANT TO KEEP THE PRIMARY GROUT LINES STRAIGHT & ALIGNED THROUGHOUT THE INSTALLATION.

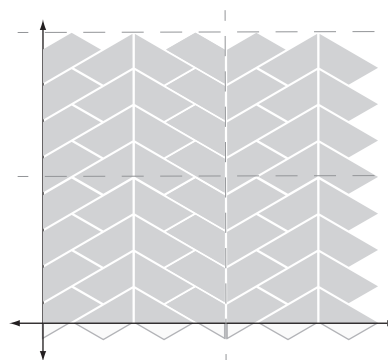

- 2 LAY OUT MODULES TO CONSTRUCT YOUR PATTERN. CUT THROUGH MOUNTING TAPE TO MAKE ADJUSTMENTS AS YOU GO.

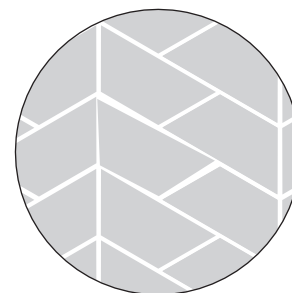

- 3 CORRECTIONS OF INDIVIDUAL TILES WITHIN FACE-MOUNTED SHEETS MAY BE NECESSARY.

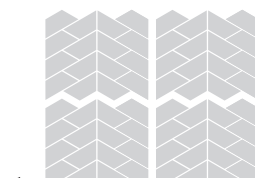

1-color pattern



2-color pattern

CLASSIC FIELD
Half Hex Twist

1/8" – 3/16" GROUT LINE

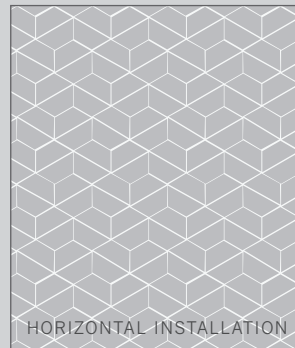

HORIZONTAL INSTALLATION



VERTICAL INSTALLATION

INSTALLATION: 1-COLOR OR 3-COLOR (B)

- 1 SELECT A HORIZONTAL OR VERTICAL ORIENTATION AND DETERMINE YOUR PRIMARY GROUT LINES. IT IS IMPORTANT TO KEEP THE PRIMARY GROUT LINES STRAIGHT & ALIGNED THROUGHOUT THE INSTALLATION.

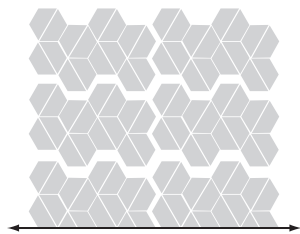
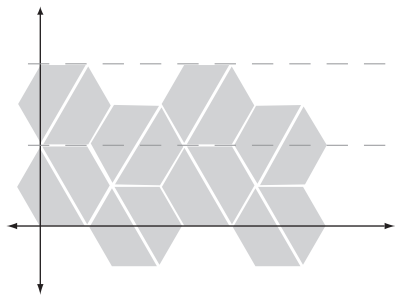

1-color pattern
MODULES ARE STACKED

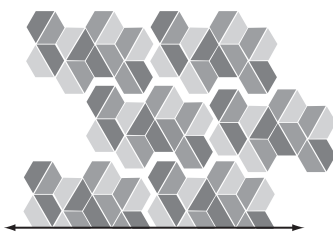

3-color (b) pattern
MODULES ARE STAGGERED

GENERAL INSTALLATION GUIDELINES

- 1 TO CREATE A FLUSH LINE AT THE INSTALLATION'S EDGE, SOME TILES WILL NEED TO BE INDIVIDUALLY CUT. THE CUT POINTS SHOULD ALL BE ALIGNED.

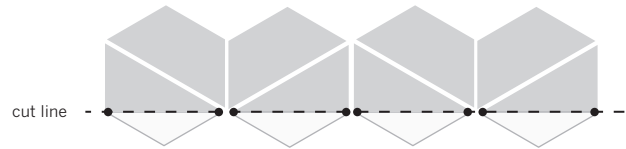
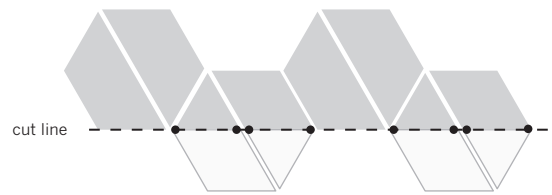

- 2 LAY OUT MODULES TO CONSTRUCT YOUR PATTERN. CUT THROUGH MOUNTING TAPE TO MAKE ADJUSTMENTS AS YOU GO. THERE WILL BE SOME VARIATION IN GROUT SPACING IN ORDER TO KEEP MODULES ALIGNED.

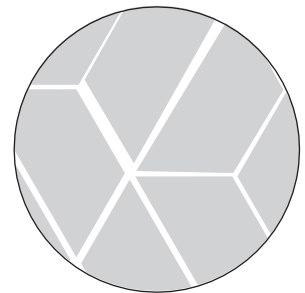

- 3 CORRECTIONS OF INDIVIDUAL TILES WITHIN FACE-MOUNTED SHEETS MAY BE NECESSARY.

CLASSIC FIELD
Half Hex Diamond Mix

1/8" – 3/16" GROUT LINE

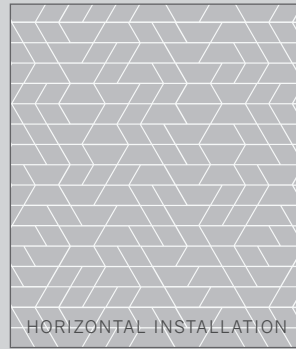

INSTALLATION: FACE-MOUNTED MODULE

1 THE COMPLETE PATTERN MODULE IS CREATED BY JOINING FOUR UNIQUE SHEETS INTO A 2x2 BLOCK AS SHOWN. EACH FACE-MOUNTED SHEET IS LABELED IN THE UPPER LEFT CORNER WITH 1A, 1B, 2A, OR 2B. THE PATTERN IS CREATED BY REPEATING THE PATTERN MODULE TO DESIRED HEIGHT OR WIDTH.

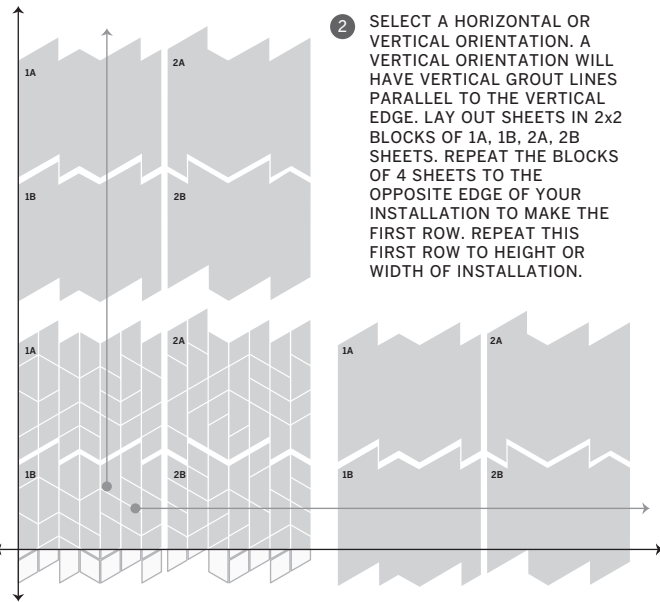
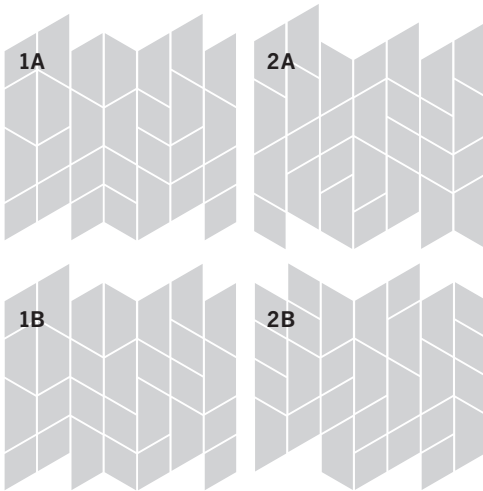

2 SELECT A HORIZONTAL OR VERTICAL ORIENTATION. A VERTICAL ORIENTATION WILL HAVE VERTICAL GROUT LINES PARALLEL TO THE VERTICAL EDGE. LAY OUT SHEETS IN 2x2 BLOCKS OF 1A, 1B, 2A, 2B SHEETS. REPEAT THE BLOCKS OF 4 SHEETS TO THE OPPOSITE EDGE OF YOUR INSTALLATION TO MAKE THE FIRST ROW. REPEAT THIS FIRST ROW TO HEIGHT OR WIDTH OF INSTALLATION.

3 TO CREATE A FLUSH LINE AT THE INSTALLATION'S EDGE, SOME TILES WILL NEED TO BE INDIVIDUALLY CUT. THE CUT POINTS SHOULD ALL BE ALIGNED. SAVE OFF-CUT TILE UNTIL LAYOUT IS COMPLETE - THEY OFTEN ARE USEFUL TO COMPLETE EDGES AT THE OPPOSITE END OF THE LAYOUT.

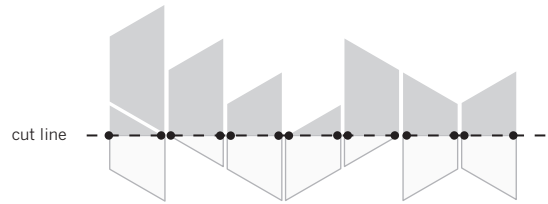

4 CUT THROUGH MOUNTING TAPE TO MAKE ADJUSTMENTS AS YOU GO. CORRECTIONS OF INDIVIDUAL TILES WITHIN FACE-MOUNTED SHEETS MAY BE NECESSARY.

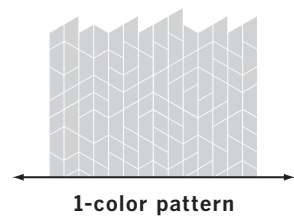
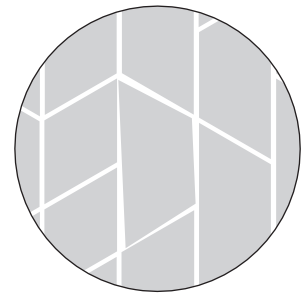

CLASSIC FIELD
Plait

1/8" - 3/16" GROUT LINE

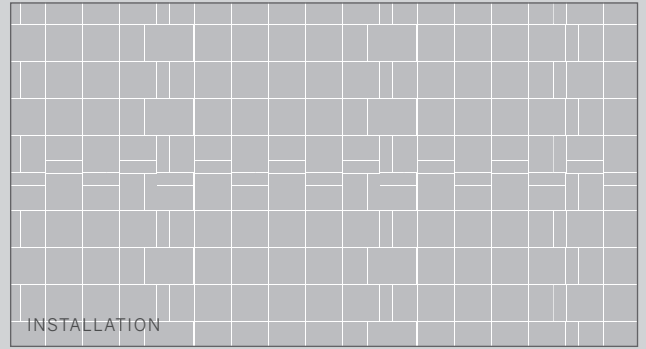

INSTALLATION: FACE-MOUNTED MODULE

- 1 SELECT A STARTING POINT AND DETERMINE YOUR PRIMARY GROUT LINES. IT IS IMPORTANT TO KEEP THE PRIMARY GROUT LINES STRAIGHT & ALIGNED THROUGHOUT THE INSTALLATION.

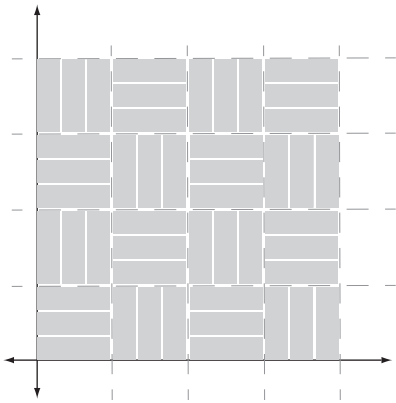

- 2 LAY OUT MODULES TO CONSTRUCT YOUR PATTERN. CUT THROUGH MOUNTING TAPE TO MAKE ADJUSTMENTS AS YOU GO. GROUT SPACING WILL SLIGHTLY INCREASE AND DECREASE IN DIFFERENT PARTS OF THE MODULE IN ORDER TO ACHIEVE A BALANCED LOOK. ONLY ADJUST SPACING THAT IS DISTRACTING OR MISALIGNED.

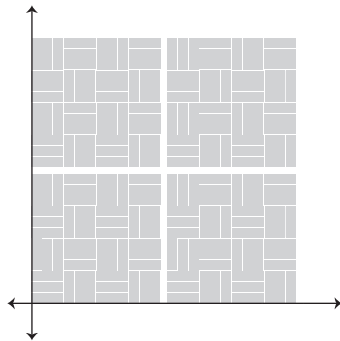

- 3 CORRECTIONS OF INDIVIDUAL TILES WITHIN FACE-MOUNTED SHEETS MAY BE NECESSARY.

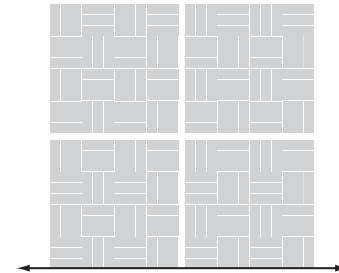
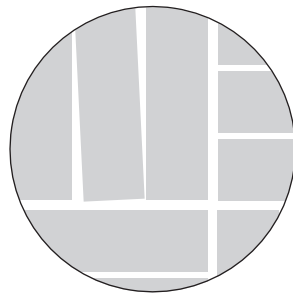

1-color pattern

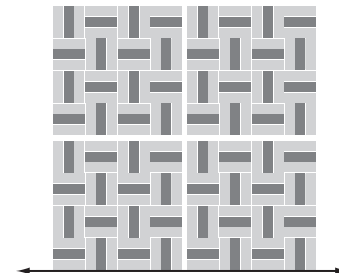

2-color pattern

CLASSIC FIELD
Basket Weave

1/8" – 3/16" GROUT LINE

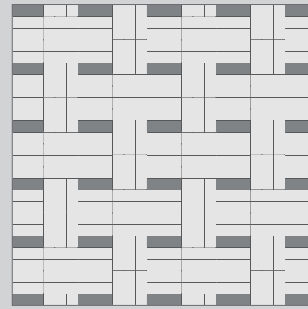

HORIZONTAL INSTALLATION

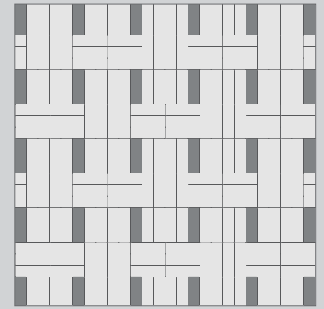

VERTICAL INSTALLATION

INSTALLATION: FACE-MOUNTED MODULE

- 1 SELECT A VERTICAL OR HORIZONTAL ORIENTATION AND DETERMINE YOUR PRIMARY GRID LINES. IT IS IMPORTANT TO KEEP YOUR PRIMARY GRID LINE STRAIGHT AND ALIGNED THROUGHOUT THE INSTALLATION.

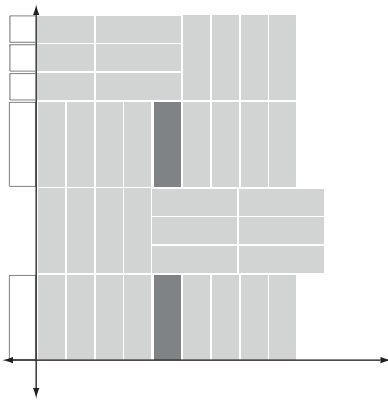

- 2 LAY OUT MODULES TO CONSTRUCT YOUR PATTERN. CUT THROUGH MOUNTING TAPE TO MAKE ADJUSTMENTS AS YOU GO. GROUT SPACING WILL SLIGHTLY INCREASE AND DECREASE IN DIFFERENT PARTS OF THE MODULE IN ORDER TO ACHIEVE A BALANCED LOOK. ONLY ADJUST SPACING THAT IS DISTRACTING OR MISALIGNED.

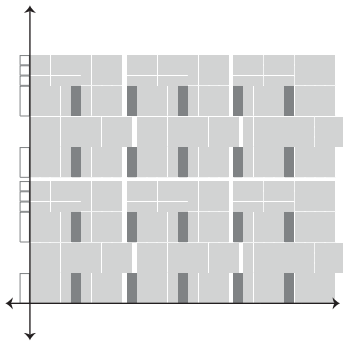

- 3 CORRECTIONS OF INDIVIDUAL TILES WITHIN FACE-MOUNTED SHEETS MAY BE NECESSARY.

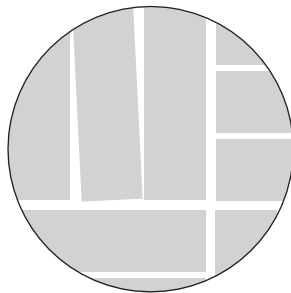

STARTING EDGE

ALTERNATIVELY YOU CAN SET YOUR PRIMARY STARTING EDGE ALIGNED TO THE SECONDARY COLOR IN THE PATTERN. THIS WILL CREATE A BORDERLESS EFFECT.

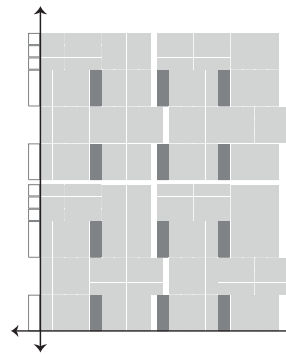

STARTING EDGE: PRIMARY COLOR

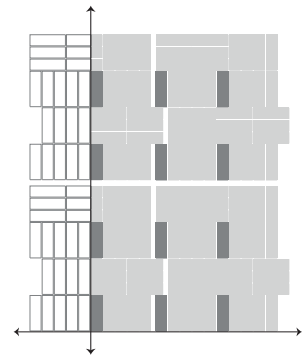

STARTING EDGE: SECONDARY COLOR

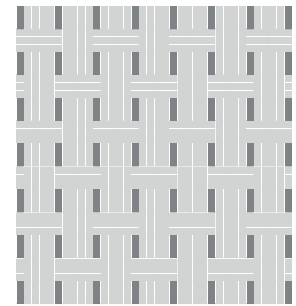
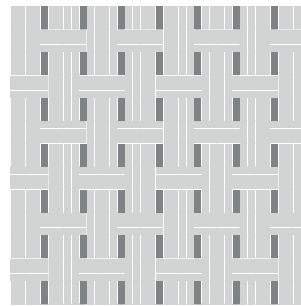



CLASSIC FIELD COLLECTION

Pre-configured, tile designs highlight the possibilities of our smallest field tile sizes. Combine glazes from our made-to-order palette to create a unique installation.

ARGYLE INSTALLATION GUIDE

Tiles come in 48pc face-mounted modules.

STEP 1

TO INSTALL PATTERN, ROTATE EVERY OTHER MODULE 180 DEGREES.

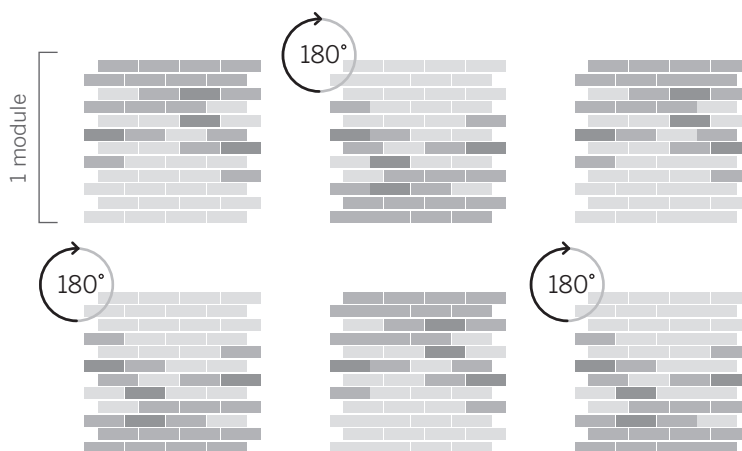

STEP 2

CUT THROUGH FACE MOUNTING TAPE TO ADJUST INDIVIDUAL TILES AS NEEDED.

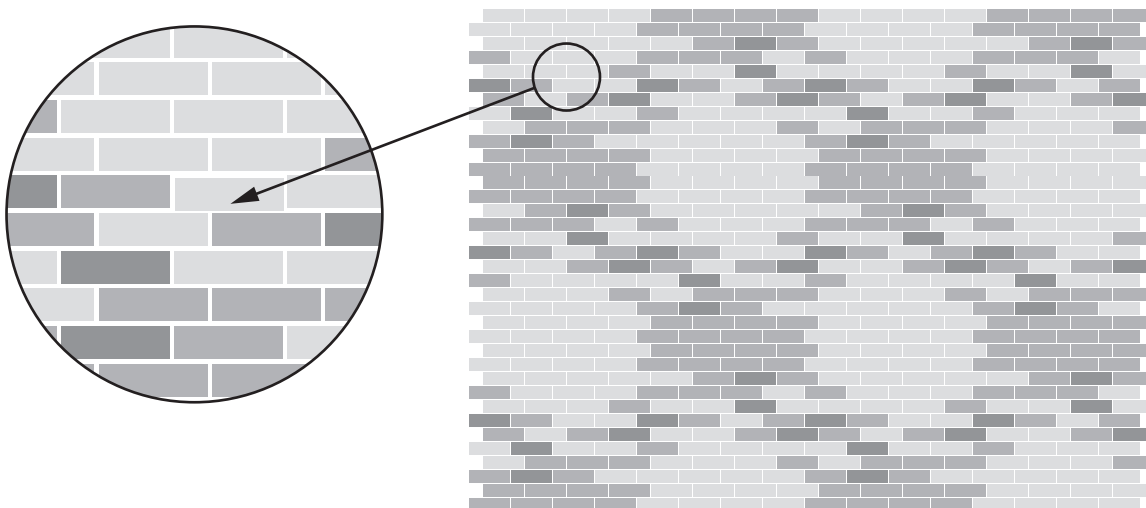



CLASSIC FIELD COLLECTION

Pre-configured, tile designs highlight the possibilities of our smallest field tile sizes. Combine glazes from our made-to-order palette to create a unique installation.

ARGYLE SPECIFICATIONS

size	face-mounting	layout	trim	grout spacing
1x3"	48 pc/module	1/3rd running bond	bullnose, Schluter edging	1/8"

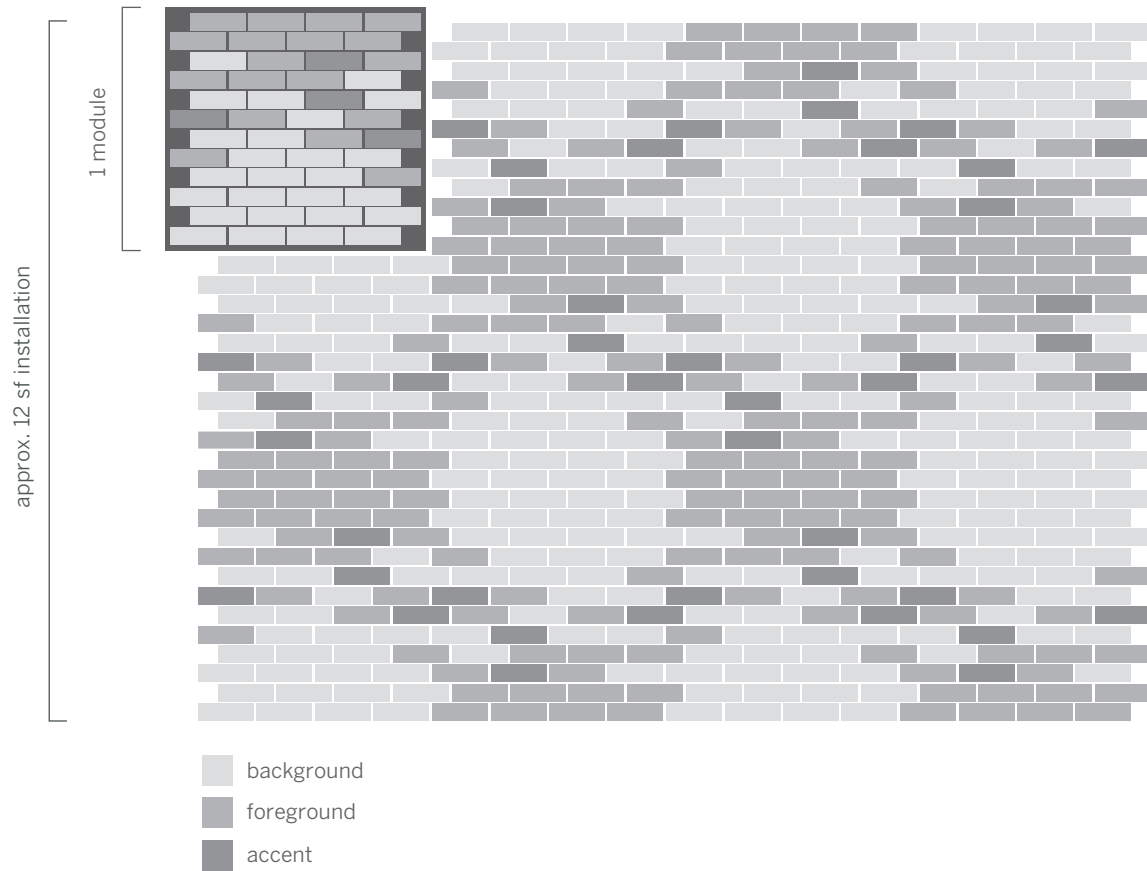

ORDER FORMULA PER [48pc] MODULE

3-color	tile size	pcs/size	% ratio
glaze 1: foreground	1x3"	18	38%
glaze 2: background	1x3"	26	54%
glaze 3: accent	1x3"	4	8%



CLASSIC FIELD COLLECTION

Pre-configured, tile designs highlight the possibilities of our smallest field tile sizes. Combine glazes from our made-to-order palette to create a unique installation.

FLEMISH BOND INSTALLATION GUIDE

Tiles come in 24pc face-mounted modules.

STEP 1

TO INSTALL PATTERN, LINE UP MODULES IN SAME ORIENTATION. 'X' DENOTES ORIENTATION.

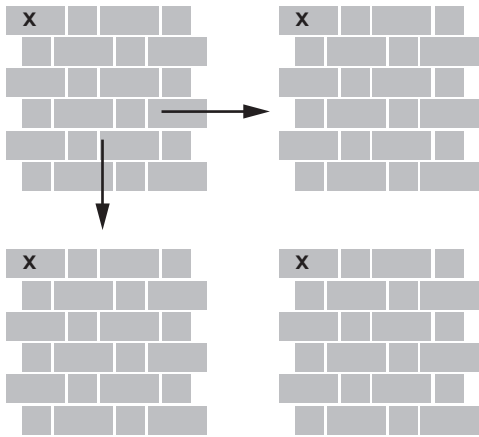

STEP 2

CUT THROUGH FACE MOUNTING TAPE TO ADJUST INDIVIDUAL TILES AS NEEDED.

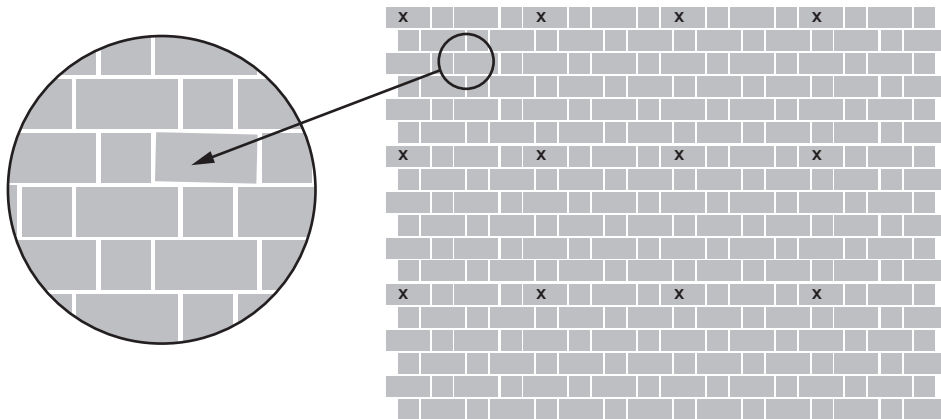



CLASSIC FIELD COLLECTION

Pre-configured, tile designs highlight the possibilities of our smallest field tile sizes. Combine glazes from our made-to-order palette to create a unique installation.

FLEMISH BOND SPECIFICATIONS

size	face-mounting	layout	trim	grout spacing
------	---------------	--------	------	---------------

2x2", 2x4"	24 pc/module	flemish bond	bullnose, Schluter edging	1/8"
-------------------	---------------------	---------------------	--------------------------------------	-------------

1 COLOR -

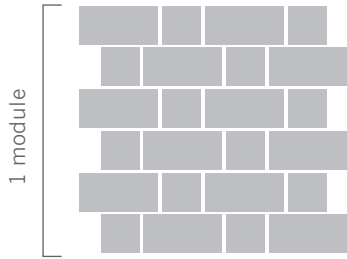

approx. 6 sf installation

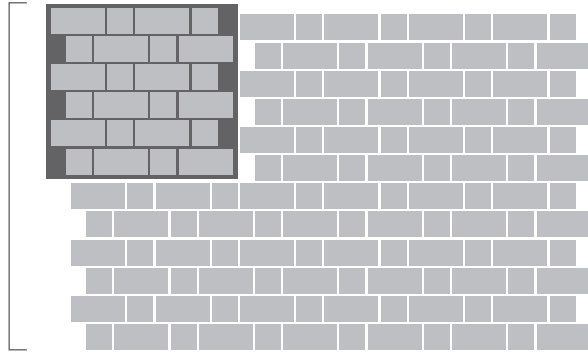



CLASSIC FIELD COLLECTION

Pre-configured, tile designs highlight the possibilities of our smallest field tile sizes. Combine glazes from our made-to-order palette to create a unique installation.

STAGGER INSTALLATION GUIDE

Tiles come in 36pc face-mounted modules.

STEP 1

TO INSTALL PATTERN, LINE UP MODULES IN SAME ORIENTATION.

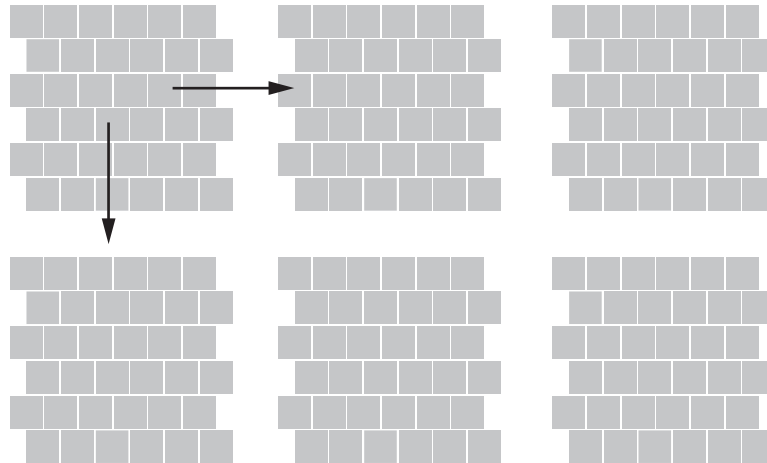

STEP 2

CUT THROUGH FACE MOUNTING TAPE TO ADJUST INDIVIDUAL TILES AS NEEDED.

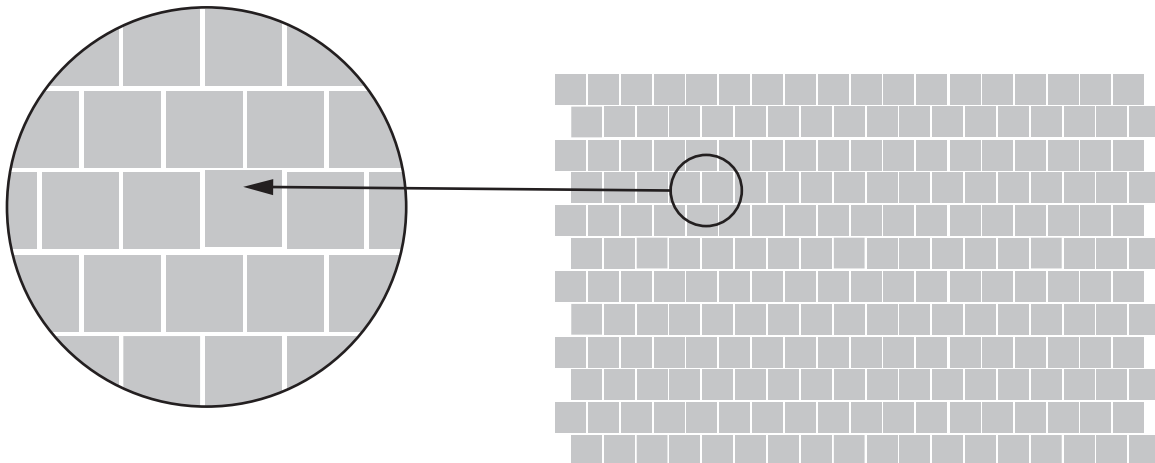



CLASSIC FIELD COLLECTION

Pre-configured, tile designs highlight the possibilities of our smallest field tile sizes. Combine glazes from our made-to-order palette to create a unique installation.

STAGGER SPECIFICATIONS

size	face-mounting	layout	trim	grout spacing
2x2"	36 pc/module	running bond	bullnose, Schluter edging	1/8"

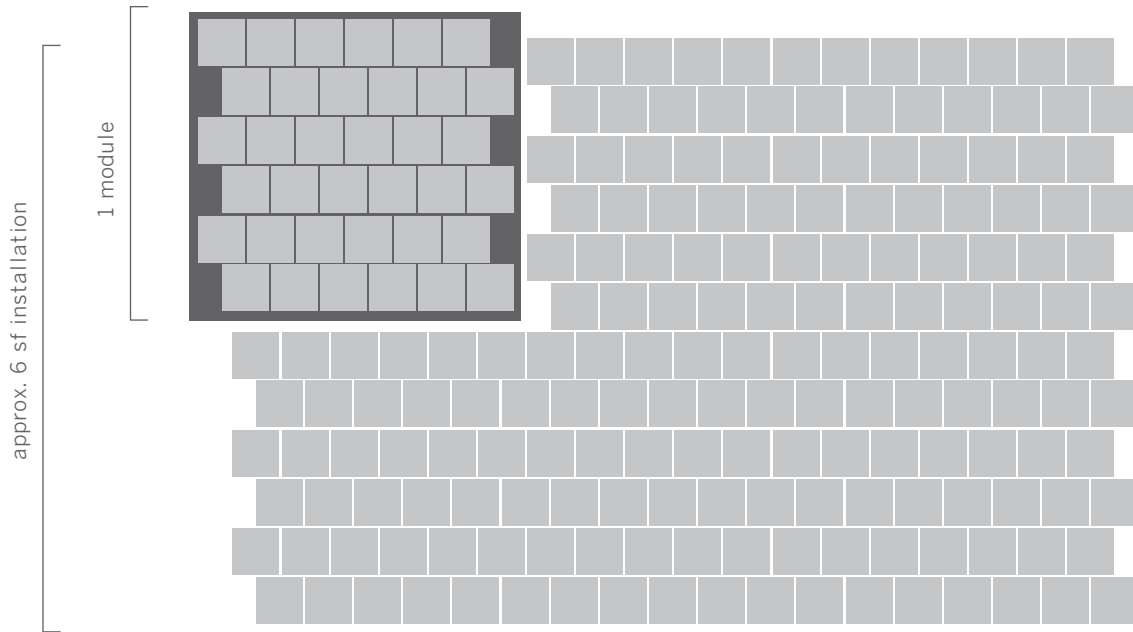



CLASSIC FIELD COLLECTION

Pre-configured, tile designs highlight the possibilities of our smallest field tile sizes. Combine glazes from our made-to-order palette to create a unique installation.

HERRINGBONE INSTALLATION GUIDE

Tiles come in 48pc face-mounted modules.

STEP 1

TO INSTALL PATTERN, LINE UP MODULES IN SAME ORIENTATION.

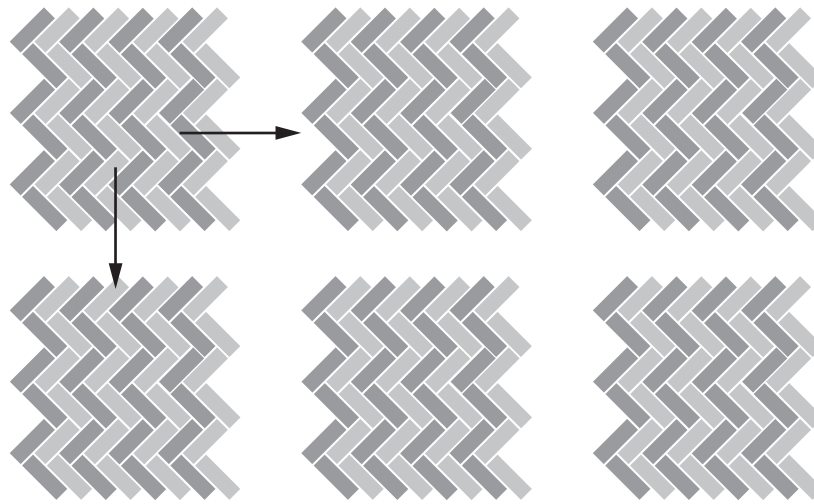

STEP 2

CUT THROUGH FACE MOUNTING TAPE TO ADJUST INDIVIDUAL TILES AS NEEDED.

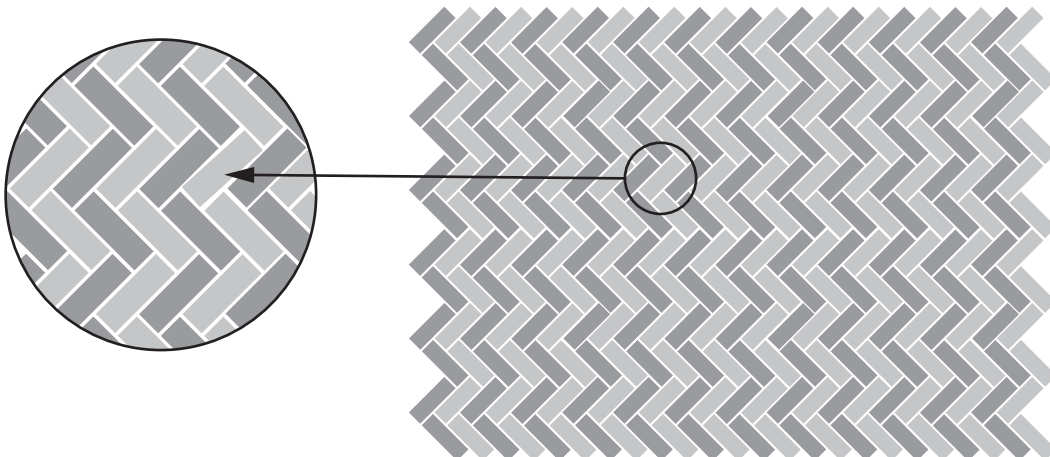



CLASSIC FIELD COLLECTION

Pre-configured, tile designs highlight the possibilities of our smallest field tile sizes. Combine glazes from our made-to-order palette to create a unique installation.

HERRINGBONE SPECIFICATIONS

size	face-mounting	layout	trim	grout spacing
1x3"	48 pc/module	herringbone	bullnose, Schluter edging	1/8"

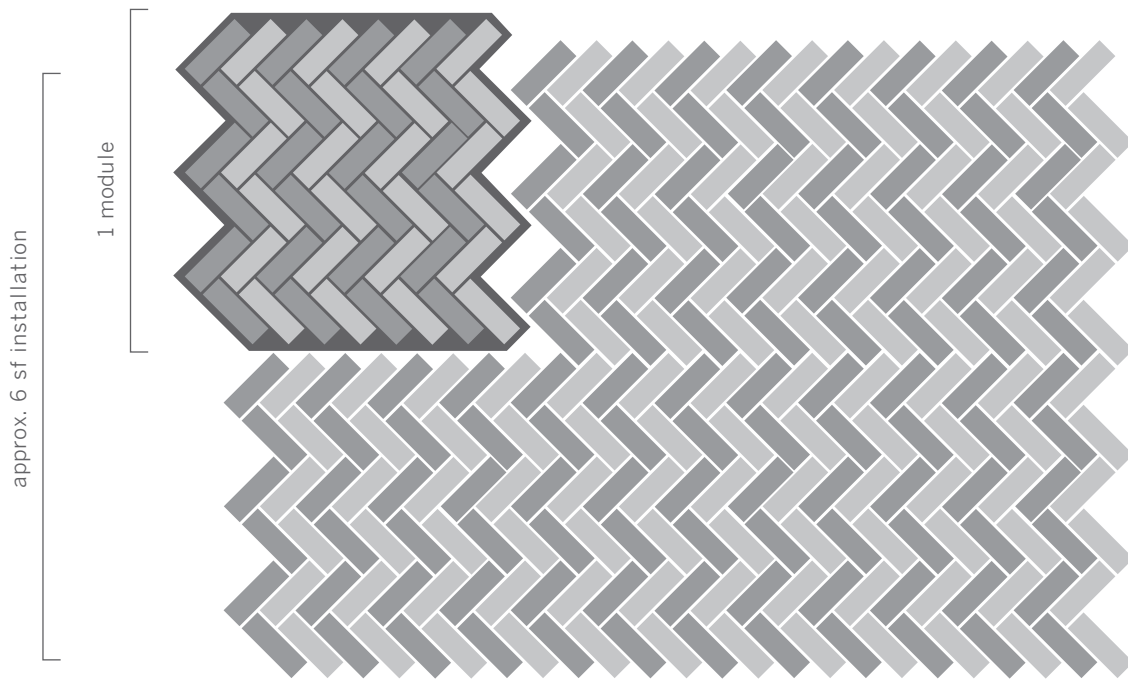

ORDER FORMULA PER [48pc] MODULE

2-color	tile size	pcs/size	% ratio
glaze 1	1x3"	24	50%
glaze 2	1x3"	24	50%