

STANLEY®

DS11 HYDRAULIC DIAMOND SAW



USER MANUAL Safety, Operation and Maintenance



© 2012 STANLEY Black & Decker, Inc.
New Britain, CT 06053
U.S.A.
62211 2/2022 Ver. 27

DECLARATION OF CONFORMITY

DECLARATION OF CONFORMITY
ÜBEREINSTIMMUNGS-ERKLÄRUNG
DECLARATION DE CONFORMITE CEE
DECLARACION DE CONFORMIDAD
DICHIARAZIONE DI CONFORMITA



I, the undersigned:
Ich, der Unterzeichnende:
Je soussigné:
El abajo firmante:
Io sottoscritto:

Nuerenberg, David

Surname and First names/Familiennname und Vornamen/Nom et prénom/Nombre y apellido/Cognome e nome

hereby declare that the equipment specified hereunder:
bestätige hiermit, daß erklaren Produkt genannten Werk oder Gerät:
déclare que l'équipement visé ci-dessous:
Por la presente declaro que el equipo se especifica a continuación:
Dichiaro che le apparecchiature specificate di seguito:

- Category: **Concrete Cutting Chainsaw, Hydraulic**
Kategorie:
Catégorie:
Categoria:
Categoria:
- Make/Marke/Marque/Marca/Marca **STANLEY**
- Type/Typ/Type/Tipo/Tipo: **DS113000, DS115000**
- Serial number of equipment:
Seriennummer des Geräts:
Numéro de série de l'équipement:
Numero de serie del equipo:
Matricola dell'attrezzatura:
All

Has been manufactured in conformity with
Wurde hergestellt in Übereinstimmung mit
Est fabriqué conformément
Ha sido fabricado de acuerdo con
E' stata costruita in conformità con

Directive/Standards Richtlinie/Standards Directives/Normes Directriz/Los Normas Direttiva/Norme	No. Nr Numéro No n.	Approved body Prüfung durch Organisme agréé Aprobado Collaudato
EN ISO	5349	Self
EN ISO	3744 (15744)	Self
EN ISO	13732-1	Self
Machinery Directive	2006/42/EC:2006	Self

- Special Provisions: **None**
Spezielle Bestimmungen:
Dispositions particulières:
Provisiones especiales:
Disposizioni speciali:
- Representative in the Union: **Patrick Vervier, Stanley Dubuis 17-19, rue Jules Berthonneau-BP 3406 41034 Blois Cedex, France.**
Vertreter in der Union/Représentant dans l'union/Representante en la Union/Rappresentante presso l'Unione

Done at/Ort/Fait à/Dado en/Fatto a STANLEY Infrastructure, Milwaukie, Oregon USA Date/Datum/le/Fecha/Data 4-30-2018

Signature/Unterschrift/Signature/Firma/Firma

Position/Position/Fonction/Cargo/Posizione North America Quality Manager

TABLE OF CONTENTS

SAFETY SYMBOLS.....	4
SAFETY PRECAUTIONS	5
TOOL STICKERS & TAGS	7
HOSE TYPES	8
HOSE RECOMMENDATIONS.....	9
HTMA / EHTMA REQUIREMENTS	10
OPERATION	11
MAINTENANCE & ADJUSTMENTS.....	14
TOOL PROTECTION & CARE.....	18
TROUBLESHOOTING	19
SPECIFICATIONS	20
ACCESSORIES	20
DS11 PARTS ILLUSTRATION	21
DS11 PARTS LIST	22
DS11 MOTOR PARTS LIST	23
DIAMOND CHAIN APPLICATIONS.....	24
UNDERWATER TOOLS DEPTH GUIDELINE.....	25

IMPORTANT

To fill out a product warranty validation form, and for information on your warranty, visit www.stanleyinfrastructure.com and select the Company tab > Warranty.

Note: The warranty validation record must be submitted to validate the warranty.

SERVICING: This manual contains safety, operation and routine maintenance instructions. STANLEY recommends that servicing of hydraulic tools, other than routine maintenance, must be performed by an authorized and certified dealer. *Please* read the following warning.

⚠ WARNING

SERIOUS INJURY OR DEATH COULD RESULT FROM THE IMPROPER REPAIR OR SERVICE OF THIS TOOL.

REPAIRS AND / OR SERVICE TO THIS TOOL MUST ONLY BE DONE BY AN AUTHORIZED AND CERTIFIED DEALER.

For the nearest certified dealer, call STANLEY Infrastructure at (503) 659-5660 and ask for a Customer Service Representative.

SAFETY PRECAUTIONS

Tool operators and maintenance personnel must always comply with the safety precautions given in this manual and on the stickers and tags attached to the tool and hose.

These precautions are given for your safety. Review them carefully before operating the tool and before performing general maintenance or repairs.

Supervising personnel should develop additional precautions relating to the specific work area and local safety regulations. Place the added precautions in the space provided.

The DS11 Concrete Chain Saw will provide safe and dependable service if operated in accordance with the instructions given in this manual. Read and understand this manual and any stickers and tags attached to the tool and hoses before operation. Failure to do so could result in personal injury or equipment damage.



- Establish a training program for all operators to ensure safe operation.
- The operator must be familiar with all prohibited work areas such as excessive slopes and dangerous terrain conditions.
- Do not operate the chain saw unless thoroughly trained or under the supervision of an instructor.
- Always wear safety equipment such as goggles, ear protection, breathing protection, head protection, leg protection, gloves, snug fitting clothing and safety shoes at all times when operating the chain saw.
- Do not overreach. Maintain proper footing and balance at all times.
- Do not inspect or clean the chain saw while the hydraulic power source is connected. Accidental engagement of the chain saw can cause serious injury.
- Always connect hoses to the chain saw hose couplers before energizing the hydraulic power source. Make sure all hose connections are tight.
- Do not operate the chain saw at fluid temperatures above 140 °F/60 °C. High temperatures can cause operator discomfort.
- Do not rely exclusively upon the safety devices built into the chain saw. As a chain saw user, several

steps must be taken to keep your cutting jobs free from accident or injury:

- a. With a basic understanding of kickbacks you can reduce or eliminate the element of surprise. Sudden surprise contributes to accidents.
 - b. Keep a good firm grip on the chain saw with both hands, the right hand on the rear handle and the left hand on the front handle, when operating the chain saw. Use a firm grip with thumbs and fingers encircling the chain saw handles. A firm grip helps reduce kickbacks and maintains control of the chain saw. Do not let go.
 - c. Make sure the area in which you are cutting is free of obstructions.
 - d. Cut at rated operating speeds (GPM).
 - e. Do not overreach or cut above shoulder height.
 - f. Only use replacement bars and chains specified by STANLEY.
- Make sure the chain guard is in place before operating the chain saw.
 - Remove or control the water slurry to prevent yourself or others from slipping while cutting.
 - Provide adequate ventilation in closed areas when operating a gas or diesel hydraulic power source.
 - Do not operate a hydraulic power source or a hydraulic diamond saw in an explosive atmosphere.
 - **WARNING:** Some dust created by power sanding, sawing, grinding, drilling, and other construction activities contains chemicals known to the State of California to cause cancer, birth defects or other reproductive harm. Some examples of these chemicals are:
 - Lead from lead-based paints,
 - crystalline silica from bricks and cement and other masonry products, and
 - arsenic and chromium from chemically-treated lumber.

Your risk from these exposures varies, depending on how often you do this type of work. To reduce your exposure to these chemicals: work in a well ventilated area, and work with approved safety equipment, such as those dust masks that are specially designed to filter out microscopic particles.

Protect yourself and those around you. Research and understand the materials you are cutting. Follow correct safety procedures and comply with all applicable national, state or provisional health and safety regulations relating to them, including,

SAFETY PRECAUTIONS

- if appropriate arranging for the safe disposal of the materials by a qualified person.
- Always be well rested and mentally alert before operating the chain saw.
- Do not allow bystanders near the chain saw when starting or cutting.
- Do not start cutting until you have a clear work area and secure footing.
- Keep all parts of the body away from the chain saw during operation, including loose clothing and long hair.
- Carry the chain saw with the tool de-energized and the bar and chain to the rear of your body.
- Do not operate a chain saw that is damaged, improperly adjusted or not completely and securely assembled. Make sure the chain stops moving when the control trigger is released.
- Keep the handle dry, clean and free of hydraulic fluid.
- Do not use the chain saw near energized transmission lines.
- Turn off the power source or move the hydraulic control valve to neutral before setting the chain saw down.
- Use a guide bar scabbard when transporting the chain saw.
- Know the location of buried or covered utilities before starting work.
- To avoid personal injury or equipment damage, all chain saw repair, maintenance and service must only be performed by authorized and properly trained personnel.
- Make sure the chain breaker and rivet spinner are securely mounted on flat, clean work surfaces. Check the mounting screws/bolts often.
- Check all chain breaker and rivet spinner components regularly for wear and general condition.
- Avoid contact with the saw bar rails as they can become very sharp during use.
- Provide adequate lighting when operating the saw in a darkened area or at night.
- Always keep critical tool markings, such as labels and warning stickers, legible. Replace stickers and decals that have become worn or damaged.
- Be observant of hydraulic and water hoses that lay about the work area, especially in trenches where they can be hidden from view due to liquids that have accumulated within the space.
- Keep all parts of the body away from the cleats that are attached to the saw, as these are sharp and can be a puncture hazard.
- Improper handling, use or maintenance can result in an oil leak or burst. Do not contact an oil leak as high pressure oil can cause injection into the body.
- Never stand in the path of the discharge, as ejection of material from the work piece can cause personal injury.
- Never use the saw in a potentially explosive atmosphere.
- **WARNING: Hydraulic fluid under pressure can cause skin injection injury. If injured by hydraulic fluid, get medical attention immediately.**

TOOL STICKERS & TAGS



28323



12535



11207

12535
Circuit "E" Decal – DS115000 Only
11207
Circuit "D" Decal – DS113000 Only



88347



88356

74804 or 74807
NAME TAG

12412
Warning Decal

88347
Composite Decal

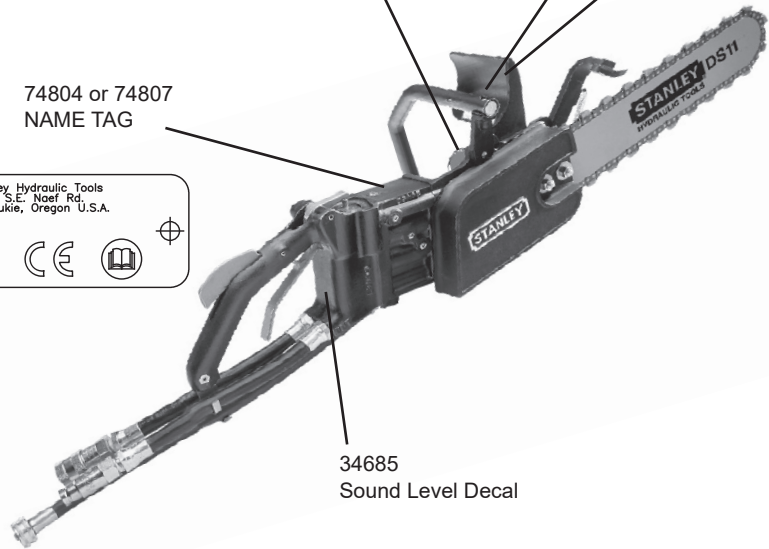

34685
Sound Level Decal

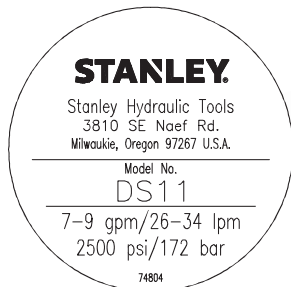

74804 DS113000 & DS113000D

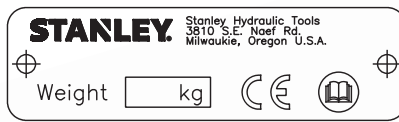

76544 CE Tool Plate



74807 DS115000 Only

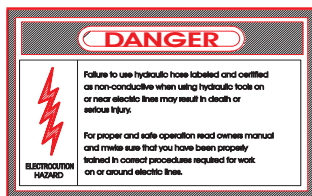

12412

Importé par: DUBUIS SAS
17-19, RUE JULES BERTHONNEAU
BP 3406 - 41034 BLOIS CEDEX - France

88345

DS113000 Only

The safety tag (p/n 88346) at right is attached to the tool when shipped from the factory. Read and understand the safety instructions listed on this tag before removal. We suggest you retain this tag and attach it to the tool when not in use.

DANGER

- NE PAS UTILISER UN FLEXIBLE HYDRAULIQUE ÉTIQUETÉ ET CERTIFIÉ NON CONDUCTEUR LORS DE L'UTILISATION D'OUTILS HYDRAULIQUES SUR OU À PROXIMITÉ DE LIGNES ÉLECTRIQUES, CELA POURRAIT ENTRAÎNER LA MORT OU DES BLESSURES GRAVES.
AVANT D'UTILISER UN FLEXIBLE ÉTIQUETÉ ET CERTIFIÉ NON CONDUCTEUR SUR OU À PROXIMITÉ DES LIGNES ÉLECTRIQUES, ASSUREZ-VOUS QUE LE FLEXIBLE EST MAINTENU COMME NON CONDUCTEUR. LE FLEXIBLE DOIT ÊTRE RÉGULIÈREMENT TESTÉ POUR SA TENUE DIELECTRIQUE CONFORMÉMENT AUX INSTRUCTIONS DE VOTRE SERVICE DE SÉCURITÉ.
- UNE FUIITE HYDRAULIQUE OU UNE EXPLOSION PEUT PROVOQUER UNE INJECTION D'HUILE DANS LE CORPS OU PROVOQUER D'AUTRES BLESSURES GRAVES.
 - NE PAS DÉPASSER LE DÉBIT ET LA PRESSION SPÉCIFIÉS POUR CET OUTIL. UN DÉBIT OU UNE PRESSION EXCESSIVE PEUT PROVOQUER UNE FUIITE OU UNE EXPLOSION.
 - NE PAS DÉPASSER LA PRESSION DE SERVICE NOMINALE DU FLEXIBLE HYDRAULIQUE UTILISÉ AVEC CET OUTIL. UNE PRESSION EXCESSIVE PEUT PROVOQUER UNE FUIITE OU UNE EXPLOSION.
 - VÉRIFIEZ QUOTIDIENNEMENT L'OUTIL. LE FLEXIBLE, LES COUPLEURS ET LES CONNECTEURS POUR DÉCELER LES FUITES. NE PAS TOUCHER LES FUITES AVEC VOS MAINS. LE CONTACT AVEC UNE FUIITE PEUT ENTRAÎNER DES BLESSURES GRAVES.
 - NE PAS SOULÉVER NI TRANSPORTER L'OUTIL PART LES FLEXIBLES. NE PAS MAL MENER LES FLEXIBLES. NE PAS UTILISER DE FLEXIBLE PLIÉ, DÉCHIRÉ OU ENDOMMAGÉ.

IMPORTANT

LIRE LE MANUEL D'UTILISATION ET LES INSTRUCTIONS DE SÉCURITÉ DE CET OUTIL AVANT DE L'UTILISER.

N'UTILISER QUE LES PIÈCES ET LES PROCÉDURES DE RÉPARATION APPROUVÉES PAR LE FABRICANT ET DÉCRITES DANS LE MANUEL D'UTILISATION.

ÉTIQUETTE À RETIRER UNIQUEMENT PAR L'OPÉRATEUR DE L'OUTIL.

VOIR L'AUTRE CÔTÉ

DANGER

- S'ASSURER QUE LES FLEXIBLES HYDRAULIQUES SOIENT CORRECTEMENT RACCORDES À L'OUTIL AVANT DE METTRE LE SYSTÈME SOUS PRESSION. LE FLEXIBLE SOUS PRESSION DOIT TOUJOURS ÊTRE RACCORDE AU PORT « IN » DE L'OUTIL. LE FLEXIBLE RETOUR PRESSION DOIT TOUJOURS ÊTRE RACCORDE AU PORT « OUT » DE L'OUTIL. L'INVERSION DU BRANCHEMENT PEUT ENTRAÎNER DES BLESSURES GRAVES.
- NE PAS RACCORDER LES OUTILS DU TYPE CENTRE FERMÉ AUX SYSTÈMES HYDRAULIQUES DU TYPE CENTRE OUVERT. CELA PEUT CAUSER UNE CHALEUR EXTRÊME DU SYSTÈME ET/OU DES BLESSURES GRAVES.
- NE PAS RACCORDER LES OUTILS DU TYPE CENTRE OUVERT AUX SYSTÈMES HYDRAULIQUES DU TYPE CENTRE FERMÉ. CELA PEUT ENTRAÎNER LA PERTE D'AUTRES FONCTIONS HYDRAULIQUES ALIMENTÉES PAR LE MÊME SYSTÈME ET/OU DES BLESSURES GRAVES.
- DES PERSONNES À PROXIMITÉ PEUVENT ÊTRE BLESSÉS DANS LA ZONE DE TRAVAIL. GARDEZ LES PERSONNES PRÉSENTES À L'ÉCART DE VOTRE AIRE DE TRAVAIL.
- PORTER UN CASQUE DE PROTECTION, DES LUNETTES DE PROTECTION, DES PROTECTIONS AUDITIVES, DES GANTS DE PROTECTIONS ET DES CHAUSSURES DE SÉCURITÉ.
- POUR ÉVITER LES BLESSURES OU DES DOMMAGES CAUSÉS À L'ÉQUIPEMENT, TOUTE RÉPARATION, ENTRETIEN ET ENTRETIEN DE L'OUTIL DOIT ÊTRE EFFECTUÉ UNIQUEMENT PAR DU PERSONNEL AUTORISÉ ET DUMENT FORMÉ.

IMPORTANT

LIRE LE MANUEL D'UTILISATION ET LES INSTRUCTIONS DE SÉCURITÉ DE CET OUTIL AVANT DE L'UTILISER.

N'UTILISER QUE LES PIÈCES ET LES PROCÉDURES DE RÉPARATION APPROUVÉES PAR LE FABRICANT ET DÉCRITES DANS LE MANUEL D'UTILISATION.

ÉTIQUETTE À RETIRER UNIQUEMENT PAR L'OPÉRATEUR DE L'OUTIL.

VOIR L'AUTRE CÔTÉ

SAFETY TAG P/N 88346 (Shown smaller than actual size)

HOSE TYPES

The rated working pressure of the hydraulic hose must be equal to or higher than the relief valve setting on the hydraulic system. There are three types of hydraulic hose that meet this requirement and are authorized for use with STANLEY hydraulic tools. They are:

Certified non-conductive — constructed of thermoplastic or synthetic rubber inner tube, synthetic fiber braid reinforcement, and weather resistant thermoplastic or synthetic rubber cover. *Hose labeled **certified non-conductive** is the only hose authorized for use near electrical conductors.*

Wire-braided (conductive) — constructed of synthetic rubber inner tube, single or double wire braid reinforcement, and weather resistant synthetic rubber cover. *This hose is **conductive** and must never be used near electrical conductors.*

Fabric-braided (not certified or labeled non-conductive) — constructed of thermoplastic or synthetic rubber inner tube, synthetic fiber braid reinforcement, and weather resistant thermoplastic or synthetic rubber cover. *This hose is **not certified non-conductive** and must never be used near electrical conductors.*

HOSE SAFETY TAGS

To help ensure your safety, the following DANGER tags are attached to all hose purchased from STANLEY. DO NOT REMOVE THESE TAGS.

If the information on a tag is illegible because of wear or damage, replace the tag immediately. A new tag may be obtained from your STANLEY Distributor.

THE TAG SHOWN BELOW IS ATTACHED TO “CERTIFIED NON-CONDUCTIVE” HOSE

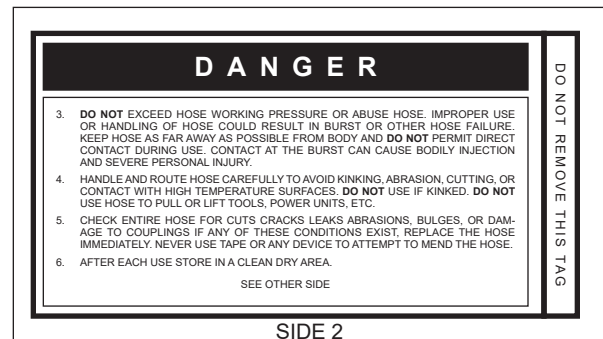
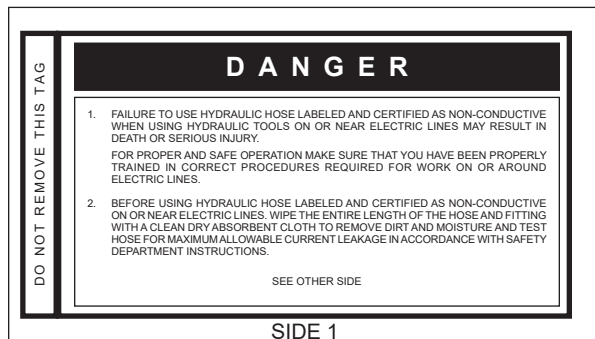

(Shown smaller than actual size)

THE TAG SHOWN BELOW IS ATTACHED TO “CONDUCTIVE” HOSE.

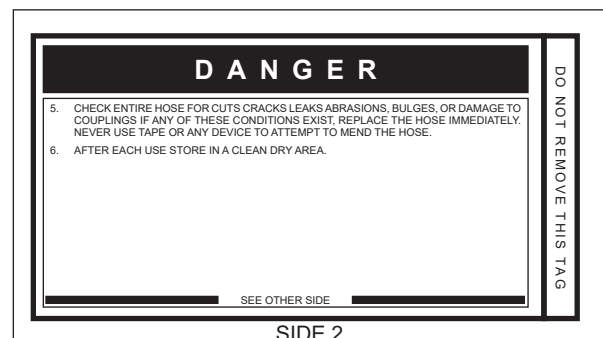
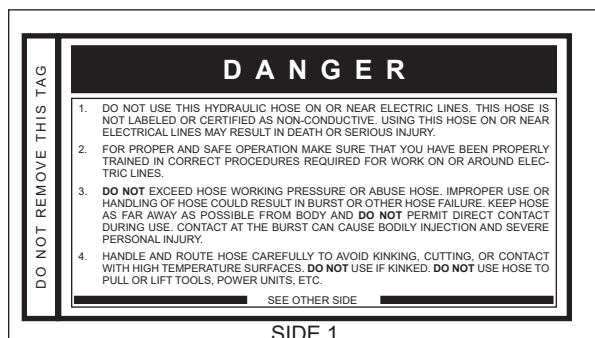

(Shown smaller than actual size)

HOSE RECOMMENDATIONS

Tool to Hydraulic Circuit Hose Recommendations

The chart to the right shows recommended minimum hose diameters for various hose lengths based on gallons per minute (GPM)/liters per minute (LPM). These recommendations are intended to keep return line pressure (back pressure) to a minimum acceptable level to ensure maximum tool performance.

This chart is intended to be used for hydraulic tool applications only based on STANLEY tool operating requirements and should not be used for any other applications.

All hydraulic hose must have at least a rated minimum working pressure equal to the maximum hydraulic system relief valve setting.

All hydraulic hose must meet or exceed specifications as set forth by SAE J517.

Oil Flow		Hose Lengths		Inside Diameter		USE (Press/Return)	Min. Working Pressure	
GPM	LPM	FEET	METERS	INCH	MM		PSI	BAR
Certified Non-Conductive Hose - Fiber Braid - for Utility Bucket Trucks								
4-9	15-34	up to 10	up to 3	3/8	10	Both	2250	155
Conductive Hose - Wire Braid or Fiber Braid - DO NOT USE NEAR ELECTRICAL CONDUCTORS								
4-6	15-23	up to 25	up to 7.5	3/8	10	Both	2500	175
4-6	15-23	26-100	7.5-30	1/2	13	Both	2500	175
5-10.5	19-40	up to 50	up to 15	1/2	13	Both	2500	175
5-10.5	19-40	51-100	15-30	5/8	16	Both	2500	175
5-10.5	19-40	100-300	30-90	5/8	16	Pressure	2500	175
10-13	38-49	up to 50	up to 15	3/4	19	Return	2500	175
10-13	38-49	51-100	15-30	5/8	16	Both	2500	175
10-13	38-49	100-200	30-60	3/4	19	Return	2500	175
13-16	49-60	up to 25	up to 8	1	25.4	Pressure	2500	175
13-16	49-60	26-100	8-30	5/8	16	Pressure	2500	175
				3/4	19	Return	2500	175
				3/4	19	Pressure	2500	175
				1	25.4	Return	2500	175

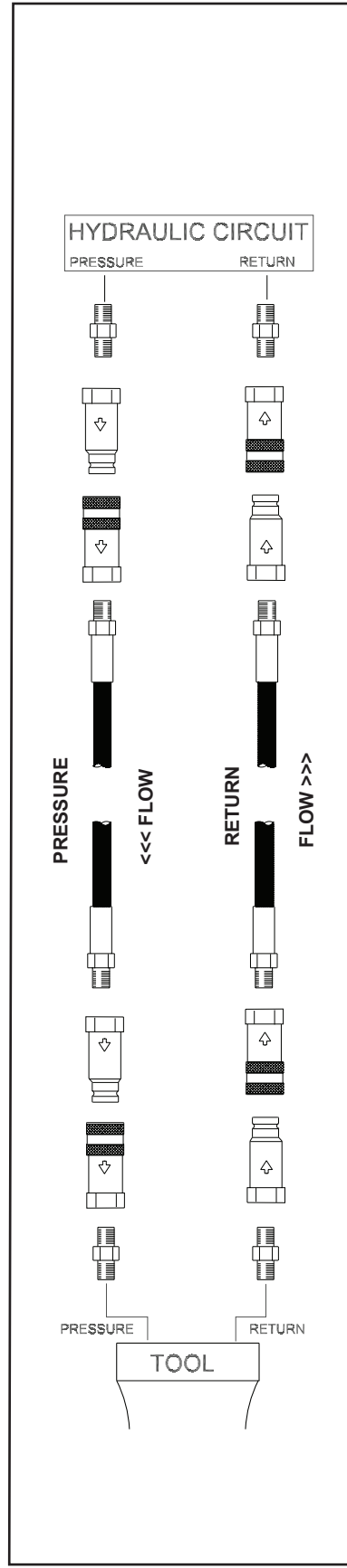

Figure 1. Typical Hose Connections





HTMA / EHTMA REQUIREMENTS

HTMA / EHTMA REQUIREMENTS

TOOL TYPE

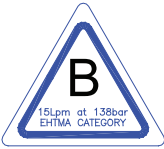
HTMA HYDRAULIC SYSTEM REQUIREMENTS	TYPE I	TYPE II	TYPE RR	TYPE III
Flow range	4-6 GPM (15-23 LPM)	7-9 GPM (26-34 LPM)	9-10.5 GPM (34-40 LPM)	11-13 GPM (42-49 LPM)
Nominal operating pressure (At the power supply outlet)	1500 psi (103 bar)	1500 psi (103 bar)	1500 psi (103 bar)	1500 psi (103 bar)
System relief valve setting (At the power supply outlet)	2100-2250 psi (145-155 bar)	2100-2250 psi (145-155 bar)	2200-2300 psi (152-159 bar)	2100-2250 psi (145-155 bar)
Maximum back pressure (At tool end of the return hose)	250 psi (17 bar)	250 psi (17 bar)	250 psi (17 bar)	250 psi (17 bar)
Measured at a max fluid viscosity of: (At minimum operating temperature)	400 ssu* (82 centistokes)	400 ssu* (82 centistokes)	400 ssu* (82 centistokes)	400 ssu* (82 centistokes)
Temperature: Sufficient heat rejection capacity to limit maximum fluid temperature to: (At maximum expected ambient temperature)	140° F (60° C)	140° F (60° C)	140° F (60° C)	140° F (60° C)
Minimum cooling capacity at a temperature difference of between ambient and fluid temps	3 hp (2.24 kW) 40° F (22° C)	5 hp (3.73 kW) 40° F (22° C)	6 hp (5.22 kW) 40° F (22° C)	7 hp (4.47 kW) 40° F (22° C)
Note: Do not operate the tool at oil temperatures above 140° F (60° C). Operation at higher temperatures can cause operator discomfort at the tool.				
Filter minimum full-flow filtration Sized for flow of at least: (For cold temp startup and maximum dirt-holding capacity)	25 microns 30 GPM (114 LPM)	25 microns 30 GPM (114 LPM)	25 microns 30 GPM (114 LPM)	25 microns 30 GPM (114 LPM)
Hydraulic fluid, petroleum based (premium grade, anti- wear, non-conductive) Viscosity (at minimum and maximum operating temps)	100-400 ssu (20-82 centistokes)	100-400 ssu (20-82 centistokes)	100-400 ssu (20-82 centistokes)	100-400 ssu (20-82 centistokes)
Note: When choosing hydraulic fluid, the expected oil temperature extremes that will be experienced in service determine the most suitable temperature viscosity characteristics. Hydraulic fluids with a viscosity index over 140 will meet the requirements over a wide range of operating temperatures.				
*SSU = Saybolt Seconds Universal				

CLASSIFICATION

EHTMA HYDRAULIC SYSTEM REQUIREMENTS					
Flow range	3.5-4.3 GPM (13.5-16.5 LPM)	4.7-5.8 GPM (18-22 LPM)	7.1-8.7 GPM (27-33 LPM)	9.5-11.6 GPM (36-44 LPM)	11.8-14.5 GPM (45-55 LPM)
Nominal operating pressure (At the power supply outlet)	1870 psi (129 bar)	1500 psi (103 bar)	1500 psi (103 bar)	1500 psi (103 bar)	1500 psi (103 bar)
System relief valve setting (At the power supply outlet)	2495 psi (172 bar)	2000 psi (138 bar)	2000 psi (138 bar)	2000 psi (138 bar)	2000 psi (138 bar)

Note: These are general hydraulic system requirements. See tool specification page for tool specific requirements.

OPERATION

PREPARATION PROCEDURES

CHECK THE POWER SOURCE

1. Using a calibrated flow meter and pressure gauge, make sure the hydraulic power source develops a flow of 7-9 GPM/26-34 LPM at 2000 psi/140 bar.
2. Make certain that the power source is equipped with a relief valve set to open at 2100-2250 psi/145-155 bar.
3. Make certain that the power source return pressure does not exceed 250 psi/17 bar.

CONNECT HYDRAULIC HOSES

1. Wipe all hose couplers with a clean lint-free cloth before making connections. If necessary, use a light-weight penetrating oil in a spray can to clean the hose couplers before each connection.
2. Connect the hoses from the hydraulic power source to the chain saw fittings or quick disconnects. It is a good practice to connect return hoses first and disconnect them last to minimize or avoid trapped pressure within the chain saw.
3. Observe the arrow on the couplers to ensure that the flow is in the proper direction. The female coupler on the chain saw is the inlet (pressure) coupler.
4. Move the hydraulic circuit control valve to the "ON" position to operate the chain saw.

Note: If uncoupled hoses are left in the sun, pressure increase inside the hoses might make them difficult to connect. Whenever possible, connect the free ends of the hoses together.

CONNECTING TO A WATER SUPPLY

1. Using a standard garden hose, connect the DS11 to a city or auxiliary water supply.
2. Holding the saw away from your body, turn the saw on and read the water pressure at the water gauge. Water pressure must be at least 35 psi/2.4 bar to avoid damage to the saw bar and chain.
3. If you plan on operating the chain saw in freezing weather, make sure you purge all the water from the system after each use.
4. If the water pressure is below 35 psi/2.4 bar, make the required adjustments to the water supply. If the required pressure cannot be achieved, you must use the STANLEY Electric Water Pump Kit (Part Number 26020 or the Power Unit Water Pump Kit P/N 29361).

CHECK CHAIN AND BAR ADJUSTMENT

1. Check the chain tension often during operation, especially during the first 1/2 hour when using a new chain. Adjust the chain accordingly when it becomes loose. Follow the procedures contained in the Maintenance and Adjustments section of this manual.
2. Make sure the chain does not exceed a clearance of 1/4 in./6 mm from the bar (see Figure 2). Exceeding the maximum clearance increases the chance of the chain being dislodged from the bar groove.

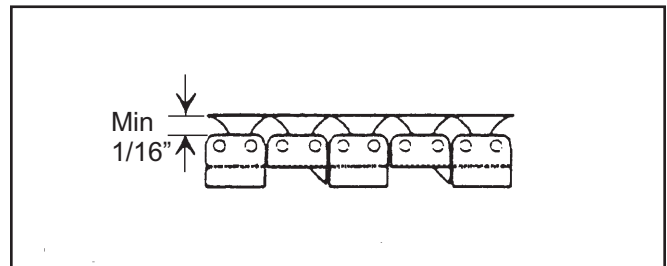

Figure 2. Maximum Chain Clearance

3. Make sure the bar attaching nuts are fully tightened and the chain guard is in place.

CHECK CHAIN SEGMENT WEAR

1. Using adjustable calipers, measure several chain segments as illustrated in Figure 3.

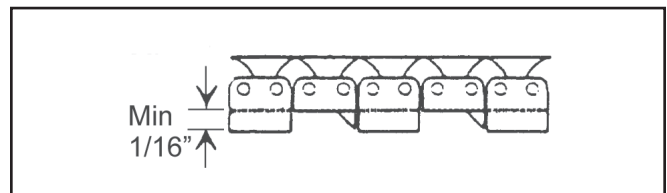

Figure 3. Chain Segment Wear

2. If the average measurement is less than 1/16-inch/1.6 mm, then the chain must be replaced. Refer to your Service Manual for chain replacement procedures.

CHECK THE WATER SUPPLY

IMPORTANT

Chain and bar damage will occur if the chain saw operates without the proper water supply.

1. Always have water running before starting the chain saw.
2. Water flow must be 4 GPM/15 LPM at 50 psi/3.5 bar

OPERATION

minimum.

OPERATING PROCEDURES

NEW SAW CHAIN BREAK-IN

1. Always make sure the bar and sprocket are in good condition.
2. Turn on the water supply.
3. Operate the chain saw for two minutes (away from the intended cut) and then check the chain tension.
4. Adjust accordingly using the procedures contained in the Maintenance and Adjustments section of this manual.

Note: The chain is designed to only operate in one direction. Make sure the chain is installed so the bumper guard proceeds each diamond segment. (See Figure 4).

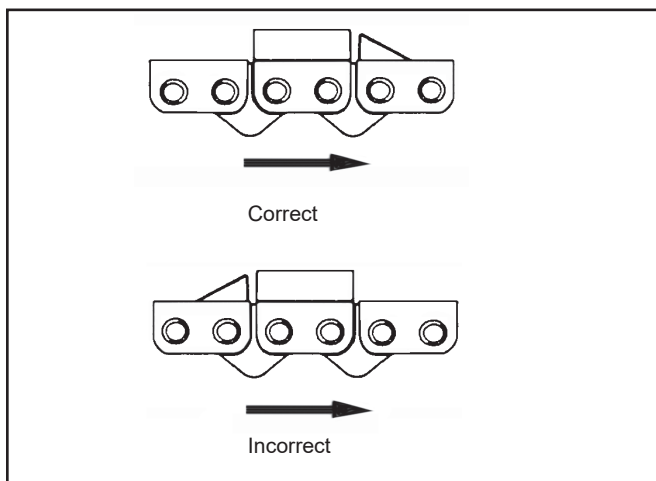

Figure 4. Chain Direction

CUTTING TIPS

NOTICE

The following are general cutting procedures and techniques. Differences in the terrain and the type of material being cut will make this information more or less valid for particular areas. For advice on specific cutting problems or techniques, consult your local STANLEY Representative. They can often provide information that will make your work safer and more productive.

PLAN THE CUT

1. Plan your cuts to prevent injury to yourself and to keep from pinching the saw bar and chain as a result of falling pieces of concrete, brick, etc.

2. Make your cuts in the order shown in Figure 5, starting with cut 1 (base horizontal cut) and proceeding with the remaining three cuts.

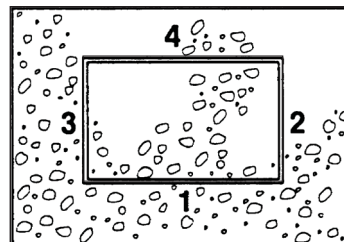

Figure 5. Making Cuts

3. Outline the concrete area with a permanent marker for a visual guide.
4. Know what kind of material and how much reinforcing you are going to cut.

TYPES OF CUTS

The DS11 can be operated using the types of cuts shown in Figure 6. When making cuts:

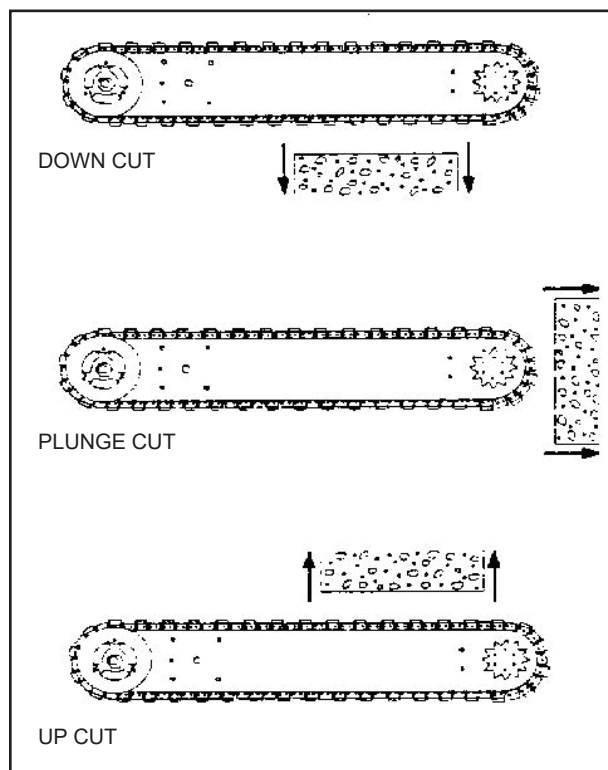

Figure 6. Types of Cuts
(Chain guard removed for clarity)

1. Do not use a cutting force in excess of 45 lbs/20 kg. Excessive force causes the chain to slow down or stall and causes premature wear of the saw bar and chain.

OPERATION

2. Always maintain a high chain speed. High chain speeds produce the best results.
3. Avoid aggressive/heavy plunge forces. Aggressive plunge force creates spalling of the concrete when the saw bar and chain exits and causes premature bar and chain wear.

COLD WEATHER OPERATION

If the saw is to be used during cold weather, preheat the hydraulic fluid at low power source speed. When using the normally recommended fluids, fluid should be at or above 50 °F/10 °C (400 ssu/82 centistokes) before use.

Damage to the hydraulic system or chain saw can result from use with fluid that is too viscous or thick.

MAINTENANCE & ADJUSTMENTS

GENERAL MAINTENANCE TIPS

Several simple maintenance tasks which, if performed, can keep a chain saw operating at a high level of efficiency. Routine maintenance also keeps replacement costs down on the parts of the chain saw, which occasionally wear out.

If any chain saw disassembly is required, refer to the Service Manual.

UNDERWATER MODEL MAINTENANCE

After each use, the movable portions of the tool that were exposed to water should be flushed with a water displacing oil, such as WD40™. Remove water and debris as follows:

1. Spray oil through the tool and displace any remaining water.
2. Spray oil into the On/Off trigger slot area
3. Dip or spray the entire tool.
4. Cycle the tool hydraulically several times before storing away.

SAW BAR RAIL

A quick check can be made to determine if saw bar rail or chain segment wear exists. Figure 6 shows a worn saw bar rail.

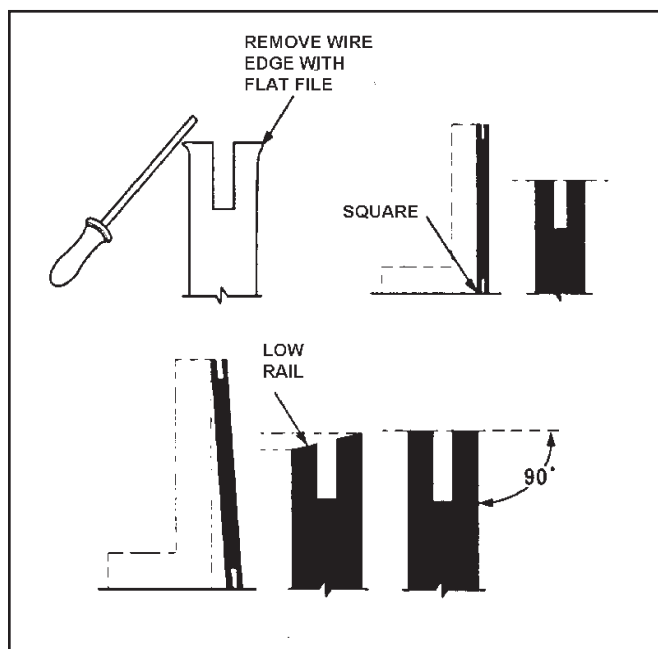

Figure 7. Rail Wear

If the saw bar rails are worn, use a flat file and dress each one until it is flat and square with the side of the saw bar (Figure 7).

Also make sure the saw bar is perfectly straight. If bows or bends are present in the saw bar, it must be replaced before dressing any rail.

ROTATING THE SAW BAR

Maximum saw bar life can be achieved by occasionally turning the bar over so the top and bottom bar surfaces wear evenly. Refer to the saw bar disassembly procedures in the Service Manual for further details.

CHAIN TENSION ADJUSTMENT

Correct chain tension is very important throughout the life of the chain. Check the chain tension often during use (when the chain saw is stopped and the saw bar and chain have cooled off). The chain should move easily around the saw bar when pulled by hand. To adjust the chain tension:

5. Turn off the water and power supplies.
6. Loosen the two saw bar attachment nuts (Item 62, Parts Illustration).
7. Using the saw bar adjustment screw (Item 65, Parts Illustration), tighten the chain until you are still able to rotate it one full revolution by hand (Figure 8).

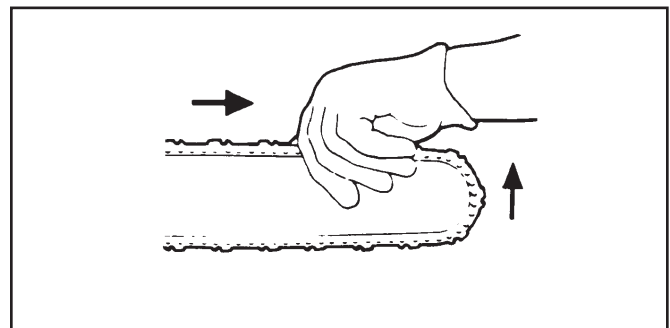

Figure 8. Pulling the Chain

8. Using hand and finger protection pull the chain around the saw bar to make sure it properly fits the sprocket and saw bar. The chain should be easily pulled.
9. Fully tighten the two saw bar attachment nuts.

Note: Adjust the chain tension each time the drive link tang hangs fully exposed from the groove at the bottom of the saw bar (Figure 9).

MAINTENANCE & ADJUSTMENTS

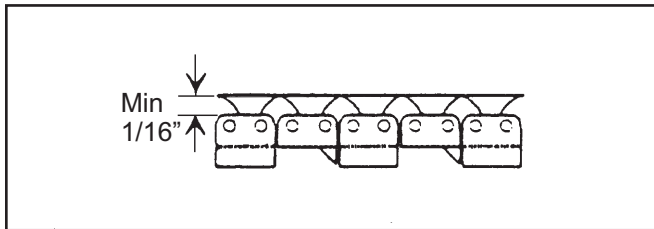

Figure 9. Exposed Drive Link Tang

SERVICING THE CHAIN

The following procedures explain how to break a chain using the STANLEY bench mounted chain breaker (P/N 20858) to remove a worn or damaged segment.

1. Mount the chain breaker flush with the side or front of a flat, clean work surface (Figure 10).

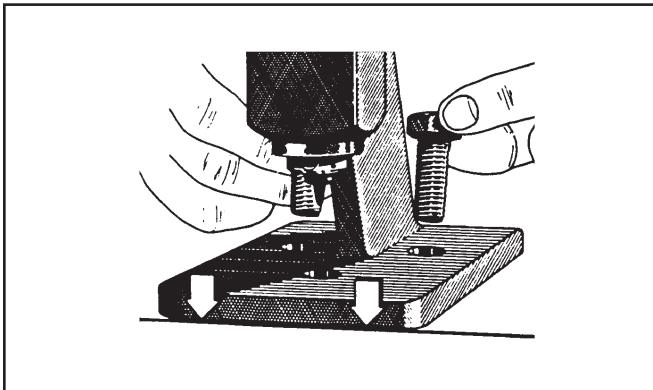

Figure 10. Chain Breaker Mounting

NOTE: The STANLEY chain breaker is only designed to remove rivet heads from the connecting links, not from a chain segment. The rivet heads shown in the shaded areas of Figure 11 are the only ones that can be removed.

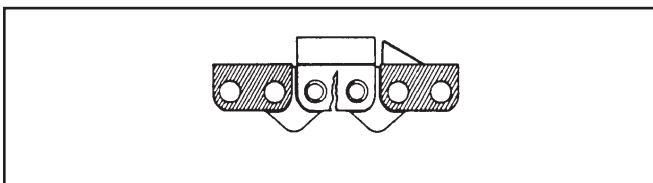

Figure 11. Removable Rivet Heads

2. Place the chain (the portion that you want broken) into the slot of the anvil pushing it forward until the bottom connecting link is flush with the far side of the slot (Figure 12).

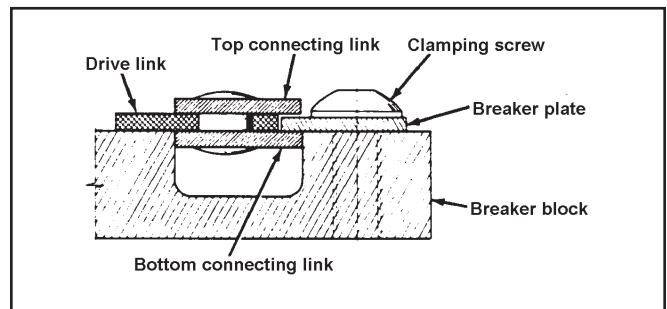
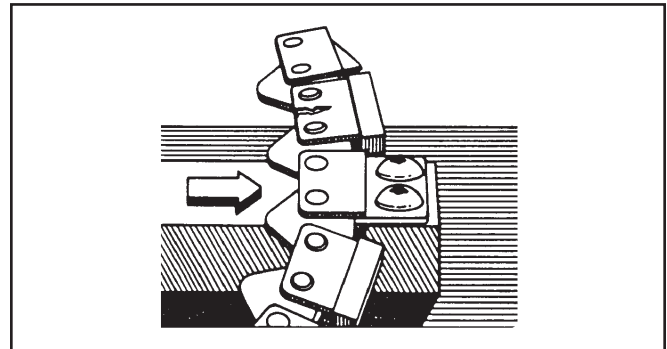

Figure 12. Inserting the Chain

3. Position the rivet head you want removed directly under the chain breaker punch and then pull the handle down far enough to remove the rivet (Figure 13). Do not use excessive force.

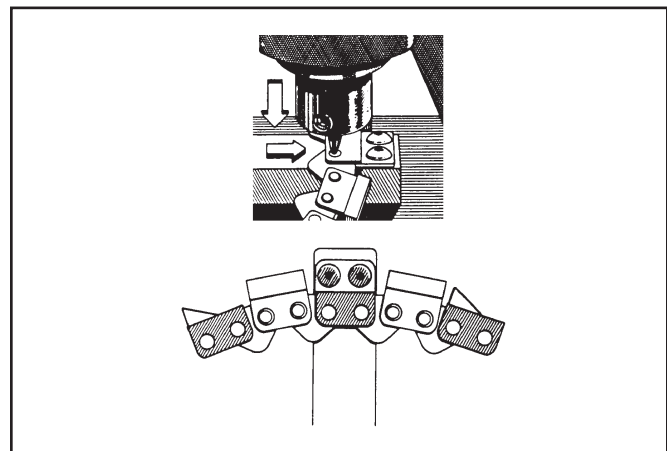

Figure 13. Removing a Rivet

REPLACING THE CHAIN BREAKER PUNCH

If the chain breaker punch (P/N 22801) becomes worn or damaged, use the following procedures for replacement.

4. Remove the punch by loosening the set screw (Figure 14).

MAINTENANCE & ADJUSTMENTS

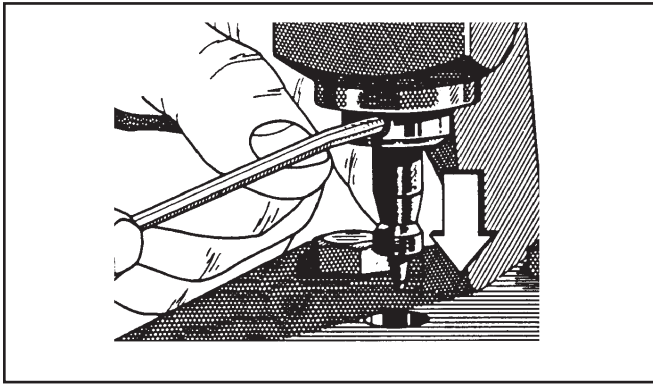

Figure 14. Removing the Punch

5. Insert a new punch into the holder and push it up until it is fully seated (Figure 15). Secure the punch to the chain breaker holder by fully tightening the set screw.

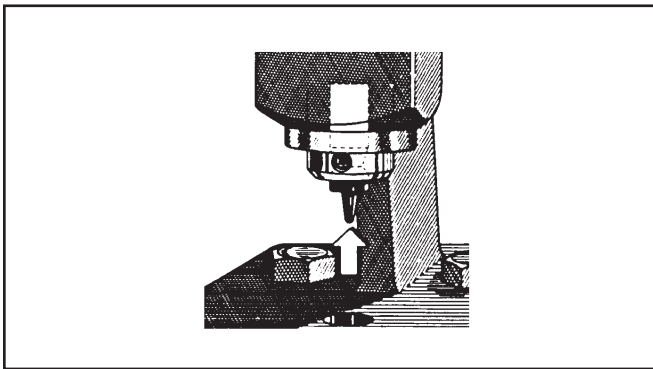

Figure 15. Replacing the Punch

SPINNING RIVETS

The following procedures explain how to spin rivets using the STANLEY bench-mounted rivet spinner (P/N 20857) to assembly the chain.

1. Mount the rivet spinner flush with the side or front of a flat, clean work surface (Figure 16).

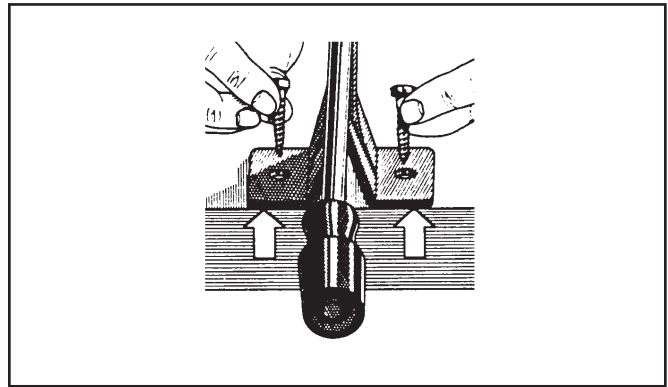

Figure 16. Rivet Spinner Mounting

2. Lay the chain across the plastic chain supports and then rotate the supports so the rivet head is centered between the take-up handle pocket and the spinner anvil (Figure 17).

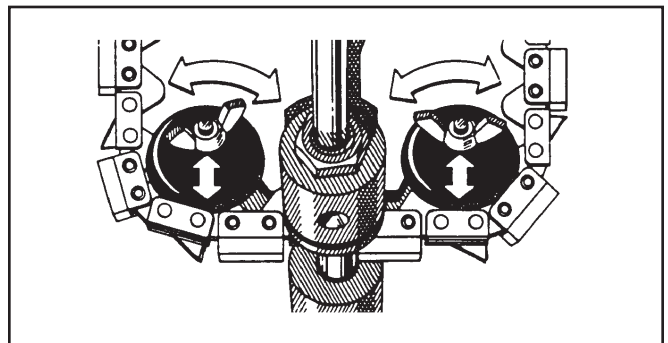

Figure 17. Positioning the Chain

3. Turn the take-up handle until the chain is tight against the spinner anvil (Figure 18).

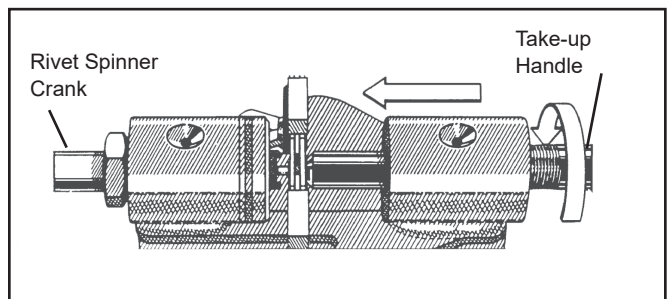

Figure 18. Securing the Chain

4. Turn the rivet spinner crank a few times to center the rivet hub in the spinner anvil (Figure 19).

MAINTENANCE & ADJUSTMENTS

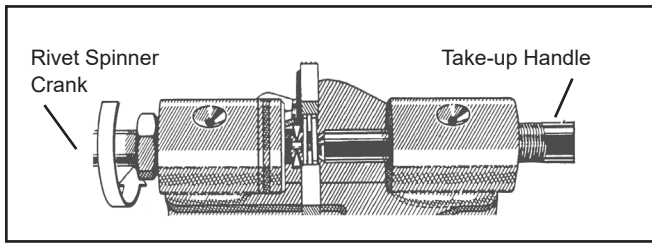

Figure 19. Centering the Rivet Hub

5. Apply a few drops of oil to the rivet hub (Figure 20).

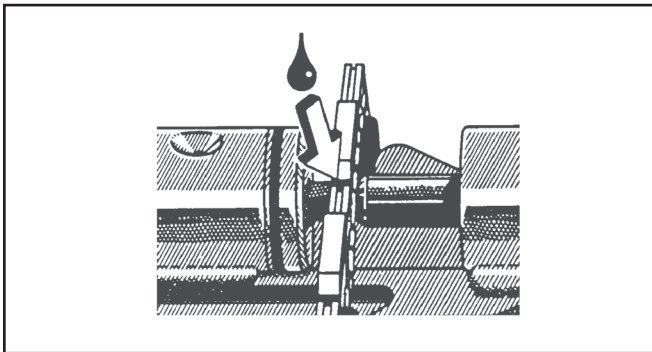

Figure 20. Applying the Oil

6. Turn the spinner crank while slowly running the take-up handle inward (approximately one full revolution) until the rivet head is formed (Figure 21).

Note: The take-up handle provides pressure while the spinner anvil forms the rivet head.

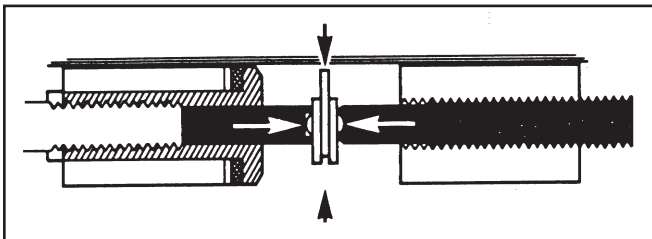

Figure 21. Forming a Rivet Head

Note: The rivet spinner is equipped with oiling chambers and should be maintained periodically with a light-weight oil (Figure 22).

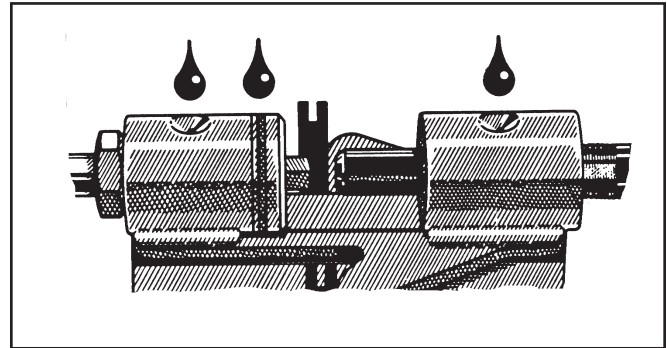

Figure 22. Spinner Oiling Chambers

TOOL PROTECTION & CARE

NOTICE

In addition to the safety precautions found in this manual, observe the following for equipment protection and care.

- Make sure all couplers are wiped clean before connection.
- The hydraulic circuit control valve must be in the "OFF" position when coupling or uncoupling hydraulic tools. Failure to do so may result in damage to the quick couplers and cause overheating of the hydraulic system.
- Always store the tool in a clean dry space, safe from damage or pilferage.
- Make sure the circuit PRESSURE hose (with male quick disconnect) is connected to the "IN" port. The circuit RETURN hose (with female quick disconnect) is connected to the opposite port. Do not reverse circuit flow. This can cause damage to internal seals.
- Always replace hoses, couplings and other parts with replacement parts recommended by STANLEY. Supply hoses must have a minimum working pressure rating of 2500 psi/172 bar.
- Do not exceed the rated flow and pressure. Rapid failure of the internal seals may result. "SPECIFICATIONS" on page 20 for correct flow rate and pressure.
- Always keep critical tool markings, such as warning stickers and tags, legible.
- Tool repair should be performed by experienced personnel only.
- Make certain that the recommended relief valves are installed in the pressure side of the system.
- Do not use the tool for applications for which it was not intended.

TROUBLESHOOTING

If symptoms of poor performance develop, the following chart can be used as a guide to correct the problem. When diagnosing faults in operation of the tool, always check that the hydraulic power source is supplying the correct hydraulic flow and pressure to the tool as listed in the following table. Use a flow meter known to be accurate. Check the flow with the hydraulic fluid temperature at least 80 °F/27 °C.

PROBLEM	CAUSE	REMEDY
Excessive vibration and cuts rough.	Loose chain tension.	Re-tension the chain.
	Excessive feed force.	Reduce feed force.
Chain saw will not cut straight.	Operator feed force not applied directly over center line of saw. Accumulated saw bar wear and uneven chain segment profile wear.	Move left hand closer to center line of saw bar. Turn the saw bar over and dress rails square. Replace the saw bar and chain.
Loss of power.	Drive sprocket slipping on Trantorque® adapter.	Adjust and tighten Trantorque® adapter, (35 ft lbs/47 Nm).
Tool does not run.	Power source not functioning.	Check power source for proper flow and pressure (7–9 GPM/26–34 LPM @ 2000 psi/140 bar).
	Coupler or hoses are blocked.	Remove obstruction.
	Mechanical failure.	Disassemble the chain saw and inspect for damage.
Tool runs backwards.	Pressure and return hoses reversed.	Connect for proper flow direction. Motor shaft must rotate clockwise.
Trigger is hard to press.	Pressure and return hoses reversed.	Connect to proper flow direction. Motor shaft must rotate clockwise.
	Back pressure too high.	Should not exceed 250 psi/17 bar @ 9 GPM/34 LPM measured at the end of the chain saw's operating hoses.
Fluid leakage around drive sprocket.	Motor shaft seal failure.	Replace as required.
Fluid leakage between the rear gear housing and the chain saw adaptor.	Motor face seal failure.	Replace as required.
Fluid leakage between the valve handle and the extension housing.	Oil tube seal failure.	Replace as required.
Fluid leakage between the extension housing assembly and the chain saw adaptor.	Oil tube seal failure.	Replace as required.
Chain saw cuts slowly.	Insufficient hydraulic fluid flow or low relief valve setting.	Adjust proper hydraulic fluid flow to proper GPM. For optimum performance, adjust relief valve to 2100–2250 psi/145–155 bar.
	Back pressure too high.	Should not exceed 250 psi/17 bar @ 9 GPM/34 LPM measured at the end of the chain saw's operating hoses.
	Loss of diamond segment side clearance.	Replace the chain.
	Hydraulic fluid mixed in water supply.	Check motor for leaks.
	Chain segment dulled because of continuous use in hard material or rebar.	Redress segment by cutting in abrasive material (i.e., concrete, build-block, etc.). Note: This indicates that the wrong chain is being used.
	Wrong chain for application.	Scale down to a lower numbered chain.
	Wire edged bar rails.	Dress rails square.
Excessive vibration and cuts rough.	Segment(s) broken or missing from chain.	Remove and repair broken segment or replace chain.

SPECIFICATIONS

Cutting Depths.....	15 or 18 inch / 38 or 46 cm
Bar Lengths	15 or 18 inch / 38 or 46 cm
Input Flow Range	
DS113000.....	7-9 GPM / 26-34 LPM
DS115000.....	12 GPM/45 LPM
Input Pressure	2000 psi / 140 bar
Chain Type	3/8 inch Pitch
Weight (with bar)	26 lbs / 12 kg
Length.....	35 or 38 inches / 89 or 97 cm
Width	9 inches / 23 cm
Lubrication / Cooling.....	Internal Water Channels in Bar
Porting	-8 SAE O-ring
Connection	3/8 inch Flush-Face Quick Disconnect Coupler
Hose Whips	Yes
Sound Power Level	103 dBa
Sound Pressure Levels	95.1 dBa
Vibration Level, 3 axis (Trigger Handle)	2.3 m/sec ²
Vibration Level, 3 axis (Non-Trigger Handle).....	2.5 m/sec ²
Uncertainty, K	1.1 m/sec ²

ACCESSORIES

Chain Repair Spinner	20857
Diamond Chain Repair Breaker.....	20858
Diamond Chain Repair Kit (includes P/N 20857 & 20858).....	20856
Wall Walker (Standard Equipment on Newer Models)	23176
Drive Sprocket.....	20470
Replacement Nose Sprocket.....	22800
Sprocket Wrench	23517
3/8 inch Flush-Face Coupler Set.....	03971
1/2 inch Flush-Face Coupler Set.....	03974
25 feet, 1/2 inch Dual Hose with Flush-Face Couplers	31972
50 feet, 1/2 inch Dual Hose with Flush-Face Couplers	31848
15 inch Bar, Sprocket Nose	30305
18 inch Bar, Sprocket Nose	30306
Diamond Ultra-32, Sealed Chain for 15 inch Bar	56801
Diamond Pinnacle-32, Sealed Chain for 15 inch Bar	56803
Diamond Ultra-37, Sealed Chain for 18 inch Bar	56802
Diamond Pinnacle-37, Sealed Chain for 18 inch Bar	58632
Water Pump, 12 VDC, DC Plug.....	DCP30100
Water Pump, 12 VDC, Battery Clips.....	DCP30101

DS11 PARTS ILLUSTRATION

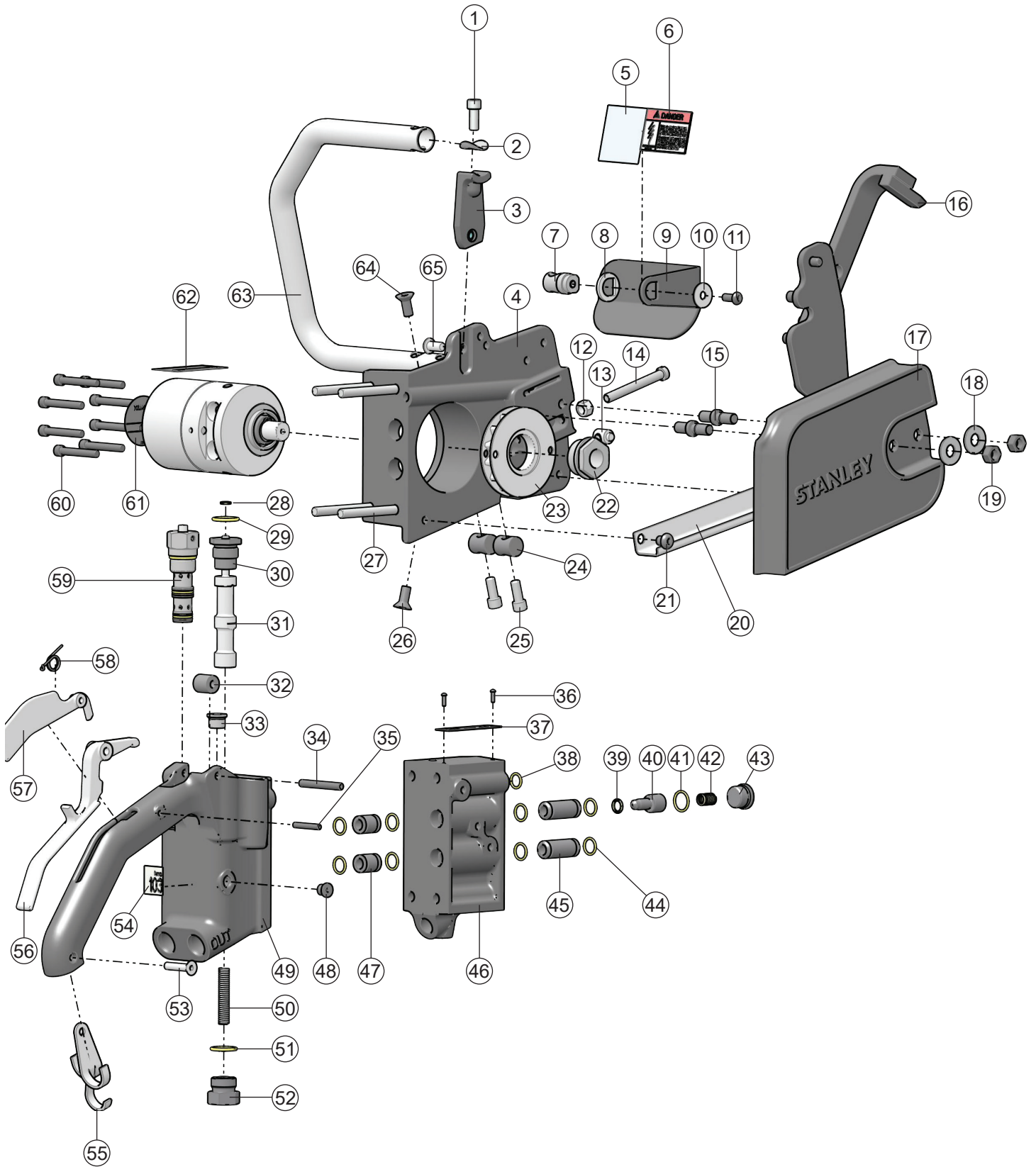

DS11 PARTS LIST

ITEM	PART NO.	QTY	DESCRIPTION
1.	02764	3	CAP SCREW - 5/16-18 X 3/4
2.	02643	3	WASHER
3.	20461	1	HANDLE STRUT
4.	22713	1	CHAIN SAW ADAPTOR
5.	88347	1	COMPOSITE SAFETY STICKER
6.	12412	1	ELECTRICAL DANGER STICKER
7.	81779	1	HANDLE RETAINER
8.	73583	1	HANDLE SPACER
9.	73582	1	HAND GUARD
10.	33261	1	WASHER
11.	33260	1	CAP SCREW - 1/4-20 X 5/8
12.	22752	1	NYLOCK NUT - 5/16-18 UNC
13.	22702	1	BAR ADJUSTMENT NUT
14.	22714	1	SCREW - 5/16-18 X 2.750
15.	20465	2	STUD
16.	23176	1	WALL WALKER
17.	22711	1	CHAIN GUARD
18.	02766	2	WASHER
19.	03276	2	HEX NUT - 3/8-16 UNC
20.	22945	1	CHAIN COVER
21.	23196	2	CAP SCREW - 5/16 UNC X 3/8 HSBH
22.	20471	1	TRANTORQUE ADAPTER - TORQUE TO 23-30 FT. LBS.
23.	20470	1	DRIVE SPROCKET
24.	02649	2	HANDLE RETAINER
25.	02764	3	CAP SCREW - 5/16-18 X 3/4
26.	03006	4	CAP SCREW - 5/16-18 X 3/4 HSFT
27.	01758	4	CAP SCREW - 5/16-18 X 3-1/2
28.	00112	1	QUAD RING - 1/4 X 3/8 X 1/16-010*
29.	01604	2	O-RING - .755 X .949 X .097-910*
30.	02931	1	ON-OFF VALVE CAP
31.	02925	1	VALVE SPOOL
32.	02920	1	ON-OFF VALVE SPACER
33.	08104	1	PLUG
34.	31804	1	ROLL PIN
35.	74841	1	ROLL PIN
36.	02004	2	DRIVE SCREW
37.	76544	1	CE TOOL PLATE
38.	00018	1	O-RING - 7/16 X 9/16 X 1/16-013*
39.	25260	1	QUAD RING - 3/8 X 1/2 X 1/16-012*
40.	20463	1	WATER VALVE
41.	01211	1	O-RING - 5/8 X 3/4 X 1/16-016*
42.	20458	1	SPRING
43.	350237	1	PLUG
44.	00175	8	O-RING - 1/2 X 5/8 X 1/16-014*
45.	02912	2	OIL TUBE
46.	20453	1	EXTENSION HOUSING

ITEM	PART NO.	QTY	DESCRIPTION
47.	00174	2	OIL TUBE
48.	350023	1	PLUG
49.	28552	1	HANDLE ASSEMBLY - INCLUDES PART 08104 - MUST PURCHASE WITH PART 74841.
50.	02916	1	SPRING
51.	01604	2	O-RING - .755 X .949 X .097-910*
52.	09437	1	PLUG
53.	00787	1	CAP SCREW - 1/4-20 X 1-1/4 HSFT SST
54.	88356	1	SOUND POWER STICKER
55.	20459	1	HOSE CLIP
56.	22707	1	TRIGGER
57.	22704	1	SAFETY CATCH
58.	22701	1	SPRING
59.	71799	1	FLOW REGULATOR CARTRIDGE (DS113000)
	71835	1	FLOW REGULATOR CARTRIDGE (DS115000)
60.	00208	8	CAP SCREW - 1/4-20 X 1-3/4
61.	74804	1	TOOL NAME TAG (DS113000)
	74807	1	TOOL NAME TAG (DS115000)
62.	09612	1	GENERAL CAUTION STICKER
63.	02936	1	HANDLE (DS113000)
	23754	1	HANDLE (DS115000)
64.	03006	4	CAP SCREW - 5/16-18 X 3/4 HSFT
65.	22715	1	CAP SCREW - 5/16-18 X 5/8
66.	11207	1	CIRCUIT TYPE "D" STICKER (DS113000) - NOT SHOWN
	12535	1	CIRCUIT TYPE "E" STICKER (DS115000) - NOT SHOWN

*SEAL KIT P/N 22798

00018	O-RING	1
00112	QUAD RING	1
00173	QUAD RING	1
00175	O-RING	8
00178	O-RING	1
00669	QUAD RING	1
01211	O-RING	2
01604	O-RING	2
01605	O-RING	3
02905	O-RING	1
03110	TEFLON SEAL	1
03847	HOSE WASHER	1
25260	QUAD RING	1
350771	O-RING	1

DS11 MOTOR PARTS LIST

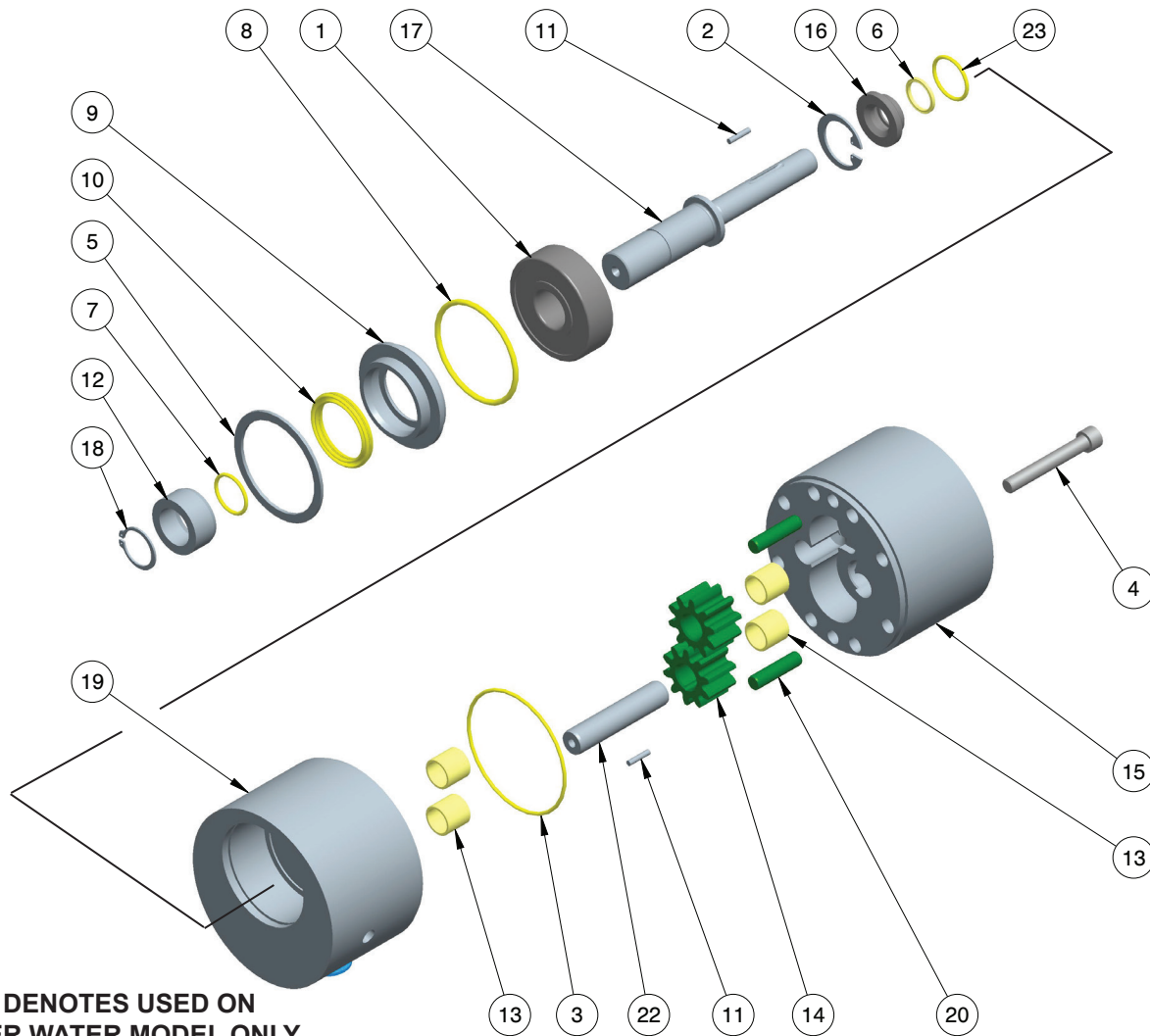

U/W - DENOTES USED ON UNDER WATER MODEL ONLY

ITEM	PART NO..	QTY	DESCRIPTION
1	00148	1	BEARING
2	00170	1	RETAINING RING
3	00178	1	O-RING*
4	00208	8	HSHCS 1/4-20 X 1-3/4
	00612	8	CAPSCREW (U/W DS115000)
5	00633	1	RET RING SPIROLOX INTERNAL
6	00669	1	QUAD RING*
7	01211	1	O-RING*
8	02905	1	O-RING*
9	03104	1	KEEPER-SEAL & BEARING
10	03110	1	ROTARY SHAFT SEAL *
11	03227	2	DOWEL PIN
	06881	2	DOWEL PIN (U/W DS115000)
12	03280	1	SPACER, SEAL RACE
13	06316	2	BUSHING, GARLOCK
14	06838	2	DRIVE GEAR
	06853	2	DRIVE GEAR (U/W DS115000)

ITEM	PART NO..	QTY	DESCRIPTION
15	06861	1	GEAR HOUSING ASSY (INCLUDES ITEMS 13 & 20)
	31849	1	GEAR HOUSING ASSY (U/W DS115000) Incds Items 13 & 20
16	19884	1	SEAL GLAND
17	20466	1	MOTOR SHAFT
	23752	1	MOTOR SHAFT (U/W)
18	20472	1	RETAINING RING EXTERNAL
19	21436	1	FRONT BEARING HOUSING ASSY (INCLUDES ITEM 13 & EXPANDER PLUGS)
20	25444	2	DOWEL PIN 1/4 X 1
	73308	1	IDLER SHAFT KEYED
	73309	1	IDLER SHAFT KEYED (U/W DS115000)
23	350771	1	O-RING*

* Part of Seal Kit 22798

DS11 PARTS LIST

ITEM	P/N	QTY	DESCRIPTION
25	03972	1	COUPLER 3/8 FEM 3/8 NPT (COUPLER SET P/N-03971)
	03975	1	COUPLER 3/8 FEM 1/2 NPT (FLUSH FACE SET P/N-03974)
26	03973	1	COUPLER 3/8 MALE 3/8 NPT (COUPLER SET P/N-03971)
	03976	1	COUPLER 3/8 MALE 1/2 NPT (FLUSH FACE SET P/N-03974)
40	20497	1	WATER HOSE ASSY
53	23517	1	SPROCKET WRENCH
60	56725	2	HOSE ASSY 18 INCH
	06830	2	HOSE ASSY 18 INCH

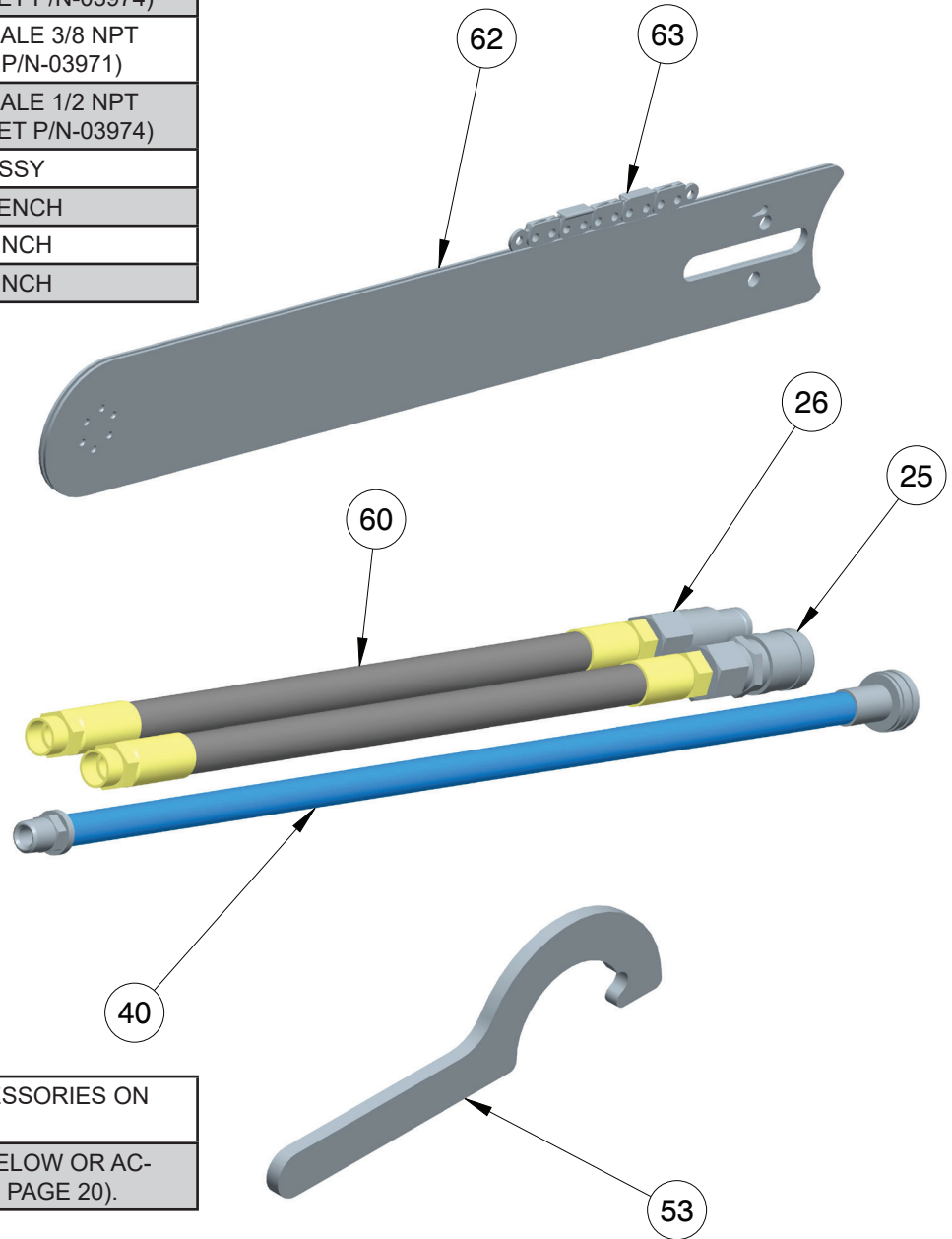

62	-----	1	BAR (SEE ACCESSORIES ON PAGE 20)
63	-----	1	CHAINS (SEE BELOW OR ACCESSORIES ON PAGE 20).

DIAMOND CHAIN APPLICATIONS

MODEL	BAR LENGTH	P/N	CORRECT APPLICATIONS
PINNACLE-32 PINNACLE-37	15 INCH 18 INCH	56803 58632	VERY HARD AGGREGATE CONCRETES (FLINT, CHERT, GRANITE, ETC). HEAVY STEEL REINFORCING, 5/8 INCH/16 MM DIAMETER AND LARGER. MEDIUM/HARD AGGREGATE CONCRETES (GRANITE, QUARTZ, RIVER ROCK, ETC). MODERATE STEEL REINFORCING (WIRE MESH 3/8-1/2 INCH/10-12 MM DIAMETER). SOFT AGGREGATE CONCRETE, CONCRETE BLOCK, MASONRY, "GREEN" CONCRETE, HIGHLY ABRASIVE CONDITIONS.
ULTRA-32 ULTRA-37	15 INCH 18 INCH	56801 56802	MEDIUM/HARD AGGREGATE CONCRETES (GRANITE, QUARTZ, RIVER ROCK, ETC). MODERATE STEEL REINFORCING (WIRE MESH 3/8-1/2 INCH/10-12 MM DIAMETER). SOFT AGGREGATE CONCRETE, CONCRETE BLOCK, MASONRY, "GREEN" CONCRETE, HIGHLY ABRASIVE CONDITIONS.

UNDERWATER TOOLS DEPTH GUIDELINE

UNDERWATER MODELS ONLY

⚠ CAUTION

Do not use hydraulic tools underwater that are not designated as an “underwater” model, or this will result in damage to the tool.

For underwater hydraulic tools the applications are broken down into four quadrants depending on type of tool and method of operation.

The types of tools are percussive and rotational, each with different characteristics allowing for different depth operation. With percussive tools, the nitrogen accumulator PSI must counter the increase in ambient pressure found at lower depths. Since there is a maximum PSI for percussive tools they are limited to certain depths. Rotational tools do not have accumulators and thus are capable of deeper depths.

The methods are broken into diver operated or remote operated vehicle (ROV). ROV's can reach lower depths and with an onboard hydraulic power source that is depth compensated, can operate hydraulic tools at depths of thousands of feet. ROV operation is still limited to the tool, for example a percussive tool has the same depth limitation whether ROV or diver operated.

OPERATION OVERVIEW

	PERCUSSIVE	ROTATIONAL
DIVER	Tools: Breakers, Hammer Drills and Chipping Hammers Max Depth: 500' - limitations due to accumulator PSI max (increase 40 PSI for every 100')	Tools: Grinders, Saws, Chain Saws Max Depth: 1000' - Reference hose sizing guide below
ROV	Tools: Breakers, Hammer Drills and Chipping Hammers Max Depth: 500' - limitations due to accumulator PSI max (increase 40 PSI for every 100')	Tools: Grinders, Saws, Chain Saws Max Depth: 1000' - Reference hose sizing guide below

RECOMMENDED HOSE DIAMETERS

DEPTH (FT)	8 GPM	12 GPM
100	5/8"	5/8"
300	3/4"	1"
600	1"	1"
1000	1"	1-1/4"



STANLEY®

STANLEY Infrastructure
6430 SE Lake Road
Portland, Oregon 97222 USA
(503) 659-5660 / Fax (503) 652-1780
www.stanleyinfrastructure.com