

STANLEY®

CS25/28 HYDRAULIC POLE CHAIN SAW



USER MANUAL Safety, Operation and Maintenance



© 2017 STANLEY Black & Decker, Inc.
New Britain, CT 06053
U.S.A.
66205 5/2020 Ver. 18

TABLE OF CONTENTS

SAFETY SYMBOLS.....	4
SAFETY PRECAUTIONS	5
ELECTRICAL HAZARDS	7
TOOL STICKERS & TAGS	9
HOSE TYPES	10
HOSE RECOMMENDATIONS.....	11
HTMA / EHTMA REQUIREMENTS	12
OPERATION	13
TOOL PROTECTION & CARE.....	17
TROUBLESHOOTING	18
SPECIFICATIONS	19
CS25 / CS28 PARTS ILLUSTRATION.....	20
CS25 / CS28 PARTS LIST.....	21

IMPORTANT

To fill out a product warranty validation form, and for information on your warranty, visit www.stanleyinfrastructure.com and select the Company tab > Warranty.

Note: The warranty validation record must be submitted to validate the warranty.

SERVICING: This manual contains safety, operation and routine maintenance instructions. STANLEY Infrastructure recommends that servicing of hydraulic tools, other than routine maintenance, must be performed by an authorized and certified dealer. Please read the following warning.

⚠ WARNING

SERIOUS INJURY OR DEATH COULD RESULT FROM THE IMPROPER REPAIR OR SERVICE OF THIS TOOL.

REPAIRS AND / OR SERVICE TO THIS TOOL MUST ONLY BE DONE BY AN AUTHORIZED AND CERTIFIED DEALER.

For the nearest certified dealer, call STANLEY Infrastructure at (503) 659-5660 and ask for a Customer Service Representative.

SAFETY PRECAUTIONS

Tool operators and maintenance personnel must always comply with the safety precautions given in this manual and on the stickers and tags attached to the tool and hose.

These safety precautions are given for your safety. Review them carefully before operating the tool and before performing general maintenance or repairs.

Supervising personnel should develop additional precautions relating to the specific work area and local safety regulations. If so, place the added precautions in the space provided in this manual.

The CS25/28 Hydraulic Pole Chain Saw will provide safe and dependable service if operated in accordance with the instructions given in this manual. Read and understand this manual and any stickers and tags attached to the tool and hoses before operation. Failure to do so could result in personal injury or equipment damage.



- Operator must start in a work area without bystanders. The operator must be familiar with all prohibited work areas such as excessive slopes and dangerous terrain conditions.
- Establish a training program for all operators to ensure safe operation.
- Do not operate the tool unless thoroughly trained or under the supervision of an instructor.
- Always wear safety equipment such as goggles, ear protection, head protection and safety shoes at all times when operating the tool.
- Do not overreach. Maintain proper footing and balance at all times.
- Do not inspect or clean the tool while the hydraulic power source is connected. Accidental engagement of the tool can cause serious injury.
- Supply hoses must have a minimum working pressure rating of 2500 psi/175 bar.
- Be sure all hose connections are tight.
- The hydraulic circuit control valve must be in the **OFF** position when coupling or uncoupling the tool. Wipe all couplers clean before connecting. Use only lint-free cloths. Failure to do so may result in damage to the quick couplers and cause overheating of the

hydraulic system.

- Do not operate the tool at oil temperatures above 140 °F/60 °C. Operation at higher oil temperatures can cause operator discomfort and may damage the tool.
- Do not operate a damaged, improperly adjusted or incompletely assembled tool.
- To avoid personal injury or equipment damage, all tool repair, maintenance and service must only be performed by authorized and properly trained personnel.
- Do not exceed the rated limits of the tool or use the tool for applications beyond its design capacity.
- Always keep critical tool markings, such as labels and warning stickers legible.
- Always replace parts with replacement parts recommended by STANLEY.
- Check fastener tightness often and before each use daily.
- Do not wear loose fitting clothing when operating the tool.
- **WARNING:** Some dust created by power sanding, sawing, grinding, drilling, and other construction activities contains chemicals known to the State of California to cause cancer, birth defects or other reproductive harm. Some examples of these chemicals are:
 - Lead from lead-based paints,
 - crystalline silica from bricks and cement and other masonry products, and
 - arsenic and chromium from chemically-treated lumber.

Your risk from these exposures varies, depending on how often you do this type of work. To reduce your exposure to these chemicals: work in a well ventilated area, and work with approved safety equipment, such as those dust masks that are specially designed to filter out microscopic particles.

Protect yourself and those around you. Research and understand the materials you are cutting. Follow correct safety procedures and comply with all applicable national, state or provisional health and safety regulations relating to them, including, if appropriate arranging for the safe disposal of the materials by a qualified person.

SAFETY PRECAUTIONS

POLE CHAIN SAW SPECIFIC SAFETY PRECAUTIONS

- Do not rely exclusively upon the safety devices built into the saw. As a pole saw user, several steps must be taken to keep your cutting jobs free from accident or injury.
- With basic understanding of kickback, you can reduce or eliminate the element of surprise. Sudden surprise contributes to accidents.
- Keep a good firm grip on the pole chain saw with both hands. Place your right hand on the rear handle and your left hand on the outer tube assembly when operating. Use a firm grip with your thumbs and fingers encircling the chain saw handle and outer tube assembly. A firm grip helps reduce kickback and maintains control of the pole chain saw. Do not let go.
- Make sure the area in which you are cutting is free of obstructions. Never allow the nose of the guide bar to contact a branch or any other obstruction that can be accidentally hit while operating the saw.
- Cut at the rated operating speeds (gpm).
- Follow the manufacturer's sharpening and maintenance instructions for the saw chain.
- Only use replacement bars and chains specified by STANLEY or equivalent.
- Make sure you're well rested and mentally alert before operating the pole chain saw.
- Do not start cutting until you have a clear work area, secure footing and a planned drop area for falling branches.
- Keep all parts of the body away from the saw chain during operation.
- Carry the saw with the unit de-energized.
- Do not operate a pole chain saw that is damaged, improperly adjusted or not completely and securely assembled. Make sure the chain stops moving when the control trigger is released.
- Use extreme caution when cutting small branches. Twigs may catch the saw chain and be whipped toward the operator or pull the operator off balance.
- When cutting a limb that is under tension, be aware of spring back so you will not be struck when the tension on the limb is released. Always cut on the outside arc or curve.
- Keep the handle dry, clean and free of hydraulic fluid.
- When using tools near energized transmission lines, make sure to use only hoses labeled and certified non-conductive.
- Turn off the power unit or move the hydraulic control valve to neutral before setting the pole chain saw down.
- Use a chain bar scabbard when transporting the saw.
- Know the location of buried or covered electrical services before starting work.
- To avoid personal injury or equipment damage, all tool repair, maintenance and service must only be performed by authorized and properly trained personnel.

ELECTRICAL HAZARDS

The following guidelines must be followed to prevent accidental contact with overhead electrical conductors and/or communication wires and cables. (Ref. ANSI Z133.1-2000)

WORKING IN PROXIMITY TO ELECTRICAL HAZARDS

An inspection shall be made by a qualified arborist to determine whether an electrical hazard exists before climbing, or otherwise entering, or performing work in or on a tree.

Only qualified line-clearance arborists or qualified line-clearance arborist trainees shall be assigned to work where an electrical hazard exists. Qualified line-clearance arborist trainees shall be under the direct supervision of qualified line-clearance arborist.

A second qualified line-clearance arborists or line-clearance arborist trainees shall be within vision or voice communication during line-clearing operations aloft when line-clearance arborists or line-clearance arborist trainees must approach closer than 10 feet (3.05 meters) to any energized electrical conductor in excess of 750 volts (primary conductor) or when:

1. Branches or limbs being removed cannot first be cut (with a pole pruner/pole saw) to sufficiently clear electrical conductors, so as to avoid contact.
2. Roping is required to remove branches or limbs from such electrical conductors. This does not apply to individuals working on behalf of, or employed by, electrical system owners/operators engaged in line-clearing operations incidental to their normal occupation.

Qualified line-clearance arborists and line-clearance arborist trainees shall maintain minimum approach distances from energized electrical conductors in accordance with Table 1.

All other arborists shall maintain a minimum approach distance from energized electrical conductors in accordance with Table 2.

Branches hanging on an energized electrical conductor shall be removed using non-conductive equipment.

Table 1 – Minimum approach distances from energized conductors for qualified line-clearance arborists and qualified line-clearance arborist trainees.

Nominal Voltage (kV phase-to-phase)	Includes 1910.269 elevation factor, sea level to 5000 ft ¹⁾		Includes 1910.269 elevation factor, 5001 – 10,000 ft ¹⁾		Includes 1910.269 elevation factor, 10,000 – 14,000 ft ¹⁾	
	ft-in	m	ft-in	m	ft-in	m
0.05 to 1.0	Avoid contact		Avoid contact		Avoid contact	
1.1 to 15.0	2-04	0.71	2-08	0.81	2-10	0.86
15.1 to 36.0	2-09	0.84	3-02	0.97	3-05	1.04
36.1 to 46.0	3-00	0.92	3-05	1.04	3-09	1.14
46.1 to 72.5	3-09	1.14	4-03	1.30	4-07	1.40
72.6 to 121.0	4-06	1.37	5-02	1.58	5-07	1.70
138.0 to 145.0	5-02	1.58	5-11	1.80	6-05	1.96
161.0 to 169.0	6-00	1.83	6-10	2.08	7-05	2.26
230.0 to 242.0	7-11	2.41	9-00	2.75	9-09	2.97
345.0 to 362.0	13-02	4.02	15-00	4.58	16-03	4.96
500.0 to 550.0	19-00	5.80	21-09	6.63	23-06	7.17
765.0 to 800.0	27-04	8.34	31-03	9.53	33-10	10.32

1) Exceeds phase-to-ground; elevation factor per 29 CFR 1910.269.

ELECTRICAL HAZARDS

Table 2 – Minimum approach distances to energized conductors for persons other than qualified line-clearance arborists and qualified line-clearance arborist trainees.

Nominal Voltage kV phase-to-phase ¹⁾	Distance	
	ft-in	m
0.0 – 1.0	10–00	3.05
1.1 – 15.0	10–00	3.05
15.1 – 36.0	10–00	3.05
36.1 – 50.0	10–00	3.05
50.1 – 72.5	10–09	3.28
72.6 – 121.0	12–04	3.76
138.0 – 145.0	13–02	4.00
161.0 – 169.0	14–00	4.24
230.0 – 242.0	16–05	4.97
345.0 – 362.0	20–05	6.17
500.0 – 550.0	26–08	8.05
785.0 – 800.0	35–00	10.55
¹⁾ Exceeds phase-to-ground.		

The tie-in position should be above the work area and located in such a way that a slip would swing the arborist away from any energized electrical conductors or other identified hazard.

While climbing, the arborist should climb on the side of the tree that is away from energized electrical conductors as required in Tables 1 and 2.

Footwear, including lineman’s overshoes, having electrical-resistant soles, shall not be considered as providing any measure of safety from electrical hazards.

Rubber gloves, with or without leather or other protective covering, shall not be considered as providing any measure of safety from electrical hazards.

Ladders, platforms and aerial devices, including insulated aerial devices, shall be subject to minimum approach distances in Table 1 and 2.

Aerial devices and attached equipment (such as chippers) contacting energized electrical conductors shall be considered energized. Contact shall be avoided, except where emergency rescue procedures are being carried out. Emergency rescue should be performed in accordance with 4.3.

STORM WORK AND EMERGENCY CONDITIONS-LINE CLEARANCE

Line clearance shall not be performed during adverse weather conditions such as thunderstorms, high winds and snow and ice storms.

Qualified line-clearance arborists and qualified line-

clearance arborists trainees performing line clearance in the aftermath of a storm or under similar conditions shall be trained in the special hazards associated with this type of work.

Line-clearance operations shall be suspended when storm work or emergency conditions develop involving energized electrical conductors. Electrical system owners/operators shall be notified immediately.

TOOL STICKERS & TAGS

THIS CHAIN SAW IS EQUIPPED WITH AN AUTOMATIC CHAIN OILER.

SEE YOUR PARTS & SERVICE BOOK FOR PROPER ADJUSTING PROCEDURES

04746
Automatic Oiler Decal



74752- CS25 Name Tag



74754
Stanley Logo Decal

CLOSED CENTER

FOR USE ON CLOSED-CENTER HYDRAULIC SYSTEM

03693
Closed Center Decal



74753- CS28 Name Tag



03786
7-9 GPM Decal

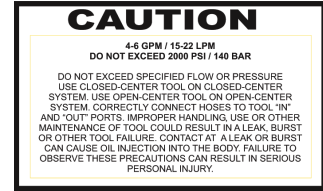

03782
4-6 GPM Decal

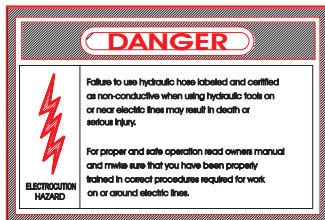

12412
Electrical Warning Decal

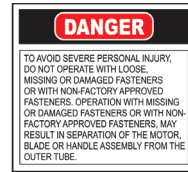

15863
Danger Decal

NOTE:

THE INFORMATION LISTED ON THE STICKERS SHOWN, MUST BE LEGIBLE AT ALL TIMES.

REPLACE DECALS IF THEY BECOME WORN OR DAMAGED. REPLACEMENTS ARE AVAILABLE FROM YOUR LOCAL STANLEY DISTRIBUTOR.

The safety tag (P/N 15875) at right is attached to the tool when shipped from the factory. Read and understand the safety instructions listed on this tag before removal. We suggest you retain this tag and attach it to the tool when not in use.

DANGER

- FAILURE TO USE HYDRAULIC HOSE LABELED AND CERTIFIED AS NON-CONDUCTIVE WHEN USING HYDRAULIC TOOLS ON OR NEAR ELECTRICAL LINES MAY RESULT IN DEATH OR SERIOUS INJURY.

BEFORE USING HOSE LABELED AND CERTIFIED AS NON-CONDUCTIVE ON OR NEAR ELECTRICAL LINES BE SURE THE HOSE IS MAINTAINED AS NON-CONDUCTIVE. THE HOSE SHOULD BE REGULARLY TESTED FOR ELECTRIC CURRENT LEAKAGE IN ACCORDANCE WITH YOUR SAFETY DEPARTMENT INSTRUCTIONS.

- A HYDRAULIC LEAK OR BURST MAY CAUSE OIL INJECTION INTO THE BODY OR CAUSE OTHER SEVERE PERSONAL INJURY.
 - DO NOT EXCEED SPECIFIED FLOW AND PRESSURE FOR THIS TOOL. EXCESS FLOW OR PRESSURE MAY CAUSE A LEAK OR BURST.
 - DO NOT EXCEED RATED WORKING PRESSURE OF HYDRAULIC HOSE USED WITH THIS TOOL. EXCESS PRESSURE MAY CAUSE A LEAK OR BURST.
 - CHECK TOOL HOSE COUPLERS AND CONNECTORS DAILY FOR LEAKS. DO NOT FEEL FOR LEAKS WITH YOUR HANDS. CONTACT WITH A LEAK MAY RESULT IN SEVERE PERSONAL INJURY.

IMPORTANT

READ OPERATION MANUAL AND SAFETY INSTRUCTIONS FOR THIS TOOL BEFORE USING IT.

USE ONLY PARTS AND REPAIR PROCEDURES APPROVED BY STANLEY AND DESCRIBED IN THE OPERATION MANUAL.

TAG TO BE REMOVED ONLY BY TOOL OPERATOR.

SEE OTHER SIDE

DANGER

- DO NOT LIFT OR CARRY TOOL BY THE HOSES. DO NOT ABUSE HOSE. DO NOT USE KINKED, TORN OR DAMAGED HOSE.
- MAKE SURE HYDRAULIC HOSES ARE PROPERLY CONNECTED TO THE TOOL BEFORE PRESSURING SYSTEM. SYSTEM PRESSURE HOSE MUST ALWAYS BE CONNECTED TO TOOL "IN" PORT. SYSTEM RETURN HOSE MUST ALWAYS BE CONNECTED TO TOOL "OUT" PORT. REVERSING CONNECTIONS MAY CAUSE REVERSE TOOL OPERATION WHICH CAN RESULT IN SEVERE PERSONAL INJURY.
- DO NOT CONNECT OPEN-CENTER TOOLS TO CLOSED-CENTER HYDRAULIC SYSTEMS. THIS MAY RESULT IN LOSS OF OTHER HYDRAULIC FUNCTIONS POWERED BY THE SAME SYSTEM AND/OR SEVERE PERSONAL INJURY.
- BYSTANDERS MAY BE INJURED IN YOUR WORK AREA. KEEP BYSTANDERS CLEAR OF YOUR WORK AREA.
- WEAR HEARING, EYE, FOOT, HAND AND HEAD PROTECTION.
- TO AVOID PERSONAL INJURY OR EQUIPMENT DAMAGE, ALL TOOL REPAIR MAINTENANCE AND SERVICE MUST ONLY BE PERFORMED BY AUTHORIZED AND PROPERLY TRAINED PERSONNEL.

IMPORTANT

READ OPERATION MANUAL AND SAFETY INSTRUCTIONS FOR THIS TOOL BEFORE USING IT.

USE ONLY PARTS AND REPAIR PROCEDURES APPROVED BY STANLEY AND DESCRIBED IN THE OPERATION MANUAL.

TAG TO BE REMOVED ONLY BY TOOL OPERATOR.

SEE OTHER SIDE

SAFETY TAG P/N 15875 (Shown smaller than actual size)

HOSE TYPES

The rated working pressure of the hydraulic hose must be equal to or higher than the relief valve setting on the hydraulic system. There are three types of hydraulic hose that meet this requirement and are authorized for use with STANLEY hydraulic tools. They are:

Certified non-conductive — constructed of thermoplastic or synthetic rubber inner tube, synthetic fiber braid reinforcement, and weather resistant thermoplastic or synthetic rubber cover. *Hose labeled **certified non-conductive** is the only hose authorized for use near electrical conductors.*

Wire-braided (conductive) — constructed of synthetic rubber inner tube, single or double wire braid reinforcement, and weather resistant synthetic rubber cover. *This hose is **conductive** and must never be used near electrical conductors.*

Fabric-braided (not certified or labeled non-conductive) — constructed of thermoplastic or synthetic rubber inner tube, synthetic fiber braid reinforcement, and weather resistant thermoplastic or synthetic rubber cover. *This hose is **not certified non-conductive** and must never be used near electrical conductors.*

HOSE SAFETY TAGS

To help ensure your safety, the following DANGER tags are attached to all hose purchased from STANLEY. DO NOT REMOVE THESE TAGS.

If the information on a tag is illegible because of wear or damage, replace the tag immediately. A new tag may be obtained from your STANLEY Distributor.

THE TAG SHOWN BELOW IS ATTACHED TO “CERTIFIED NON-CONDUCTIVE” HOSE

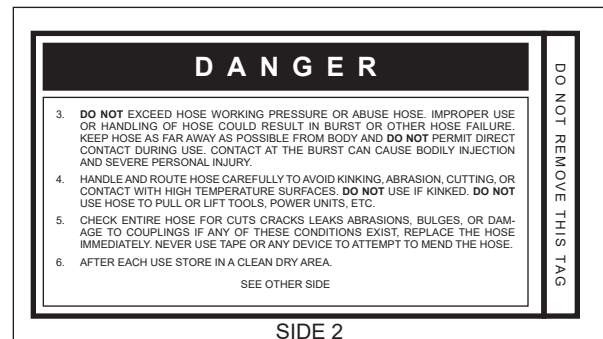
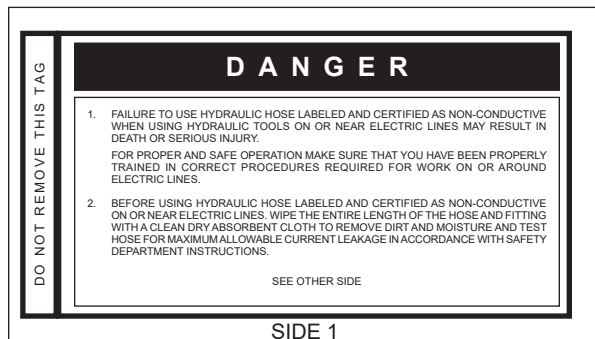

(Shown smaller than actual size)

THE TAG SHOWN BELOW IS ATTACHED TO “CONDUCTIVE” HOSE.

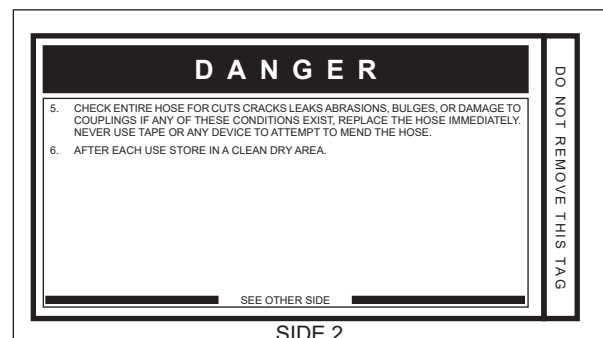
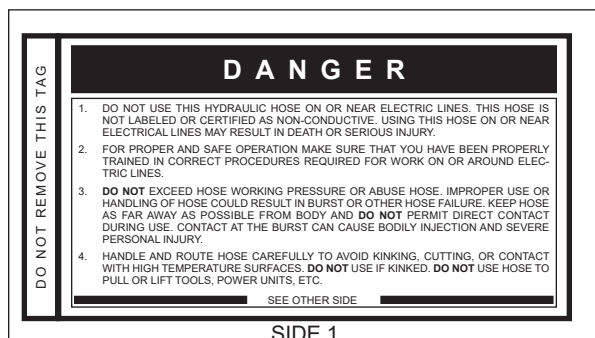

(Shown smaller than actual size)

HOSE RECOMMENDATIONS

Tool to Hydraulic Circuit Hose Recommendations

The chart to the right shows recommended minimum hose diameters for various hose lengths based on gallons per minute (GPM)/liters per minute (LPM). These recommendations are intended to keep return line pressure (back pressure) to a minimum acceptable level to ensure maximum tool performance.

This chart is intended to be used for hydraulic tool applications only based on STANLEY tool operating requirements and should not be used for any other applications.

All hydraulic hose must have at least a rated minimum working pressure equal to the maximum hydraulic system relief valve setting.

All hydraulic hose must meet or exceed specifications as set forth by SAE J517.

Oil Flow		Hose Lengths		Inside Diameter		USE (Press/Return)	Min. Working Pressure	
GPM	LPM	FEET	METERS	INCH	MM		PSI	BAR
Certified Non-Conductive Hose - Fiber Braid - for Utility Bucket Trucks								
4-9	15-34	up to 10	up to 3	3/8	10	Both	2250	155
Conductive Hose - Wire Braid or Fiber Braid - DO NOT USE NEAR ELECTRICAL CONDUCTORS								
4-6	15-23	up to 25	up to 7.5	3/8	10	Both	2500	175
4-6	15-23	26-100	7.5-30	1/2	13	Both	2500	175
5-10.5	19-40	up to 50	up to 15	1/2	13	Both	2500	175
5-10.5	19-40	51-100	15-30	5/8	16	Both	2500	175
5-10.5	19-40	100-300	30-90	5/8	16	Pressure	2500	175
10-13	38-49	up to 50	up to 15	3/4	19	Return	2500	175
10-13	38-49	51-100	15-30	5/8	16	Both	2500	175
10-13	38-49	100-200	30-60	3/4	19	Pressure	2500	175
13-16	49-60	up to 25	up to 8	1	25.4	Return	2500	175
13-16	49-60	26-100	8-30	5/8	16	Pressure	2500	175
				3/4	19	Return	2500	175
				3/4	19	Pressure	2500	175
				1	25.4	Return	2500	175

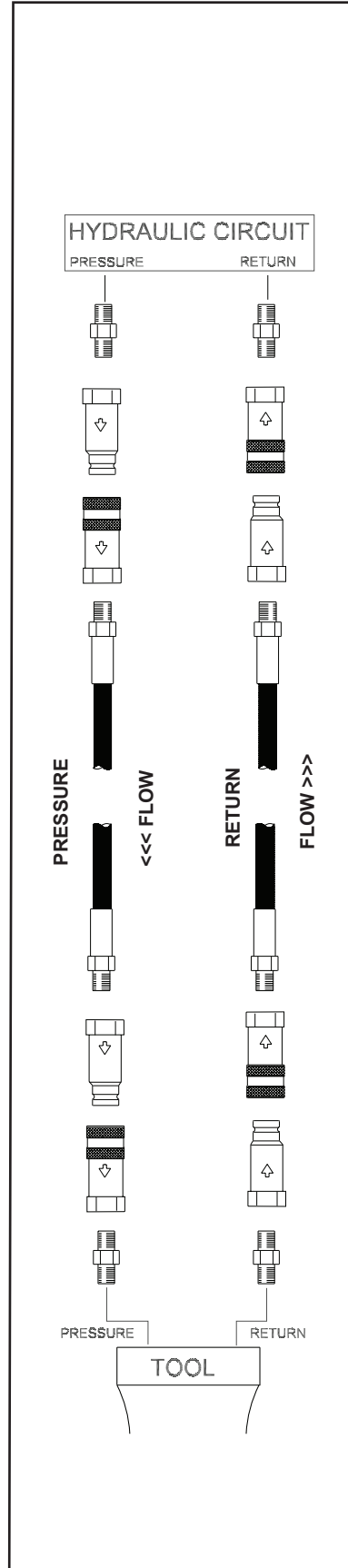

Figure 1. Typical Hose Connections





HTMA / EHTMA REQUIREMENTS

HTMA / EHTMA REQUIREMENTS

TOOL TYPE

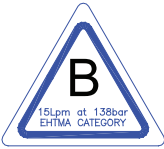
HTMA HYDRAULIC SYSTEM REQUIREMENTS	TYPE I	TYPE II	TYPE RR	TYPE III
Flow range	4-6 GPM (15-23 LPM)	7-9 GPM (26-34 LPM)	9-10.5 GPM (34-40 LPM)	11-13 GPM (42-49 LPM)
Nominal operating pressure (At the power supply outlet)	1500 psi (103 bar)	1500 psi (103 bar)	1500 psi (103 bar)	1500 psi (103 bar)
System relief valve setting (At the power supply outlet)	2100-2250 psi (145-155 bar)	2100-2250 psi (145-155 bar)	2200-2300 psi (152-159 bar)	2100-2250 psi (145-155 bar)
Maximum back pressure (At tool end of the return hose)	250 psi (17 bar)	250 psi (17 bar)	250 psi (17 bar)	250 psi (17 bar)
Measured at a max fluid viscosity of: (At minimum operating temperature)	400 ssu* (82 centistokes)	400 ssu* (82 centistokes)	400 ssu* (82 centistokes)	400 ssu* (82 centistokes)
Temperature: Sufficient heat rejection capacity to limit maximum fluid temperature to: (At maximum expected ambient temperature)	140° F (60° C)	140° F (60° C)	140° F (60° C)	140° F (60° C)
Minimum cooling capacity at a temperature difference of between ambient and fluid temps	3 hp (2.24 kW) 40° F (22° C)	5 hp (3.73 kW) 40° F (22° C)	6 hp (5.22 kW) 40° F (22° C)	7 hp (4.47 kW) 40° F (22° C)
Note: Do not operate the tool at oil temperatures above 140° F (60° C). Operation at higher temperatures can cause operator discomfort at the tool.				
Filter minimum full-flow filtration Sized for flow of at least: (For cold temp startup and maximum dirt-holding capacity)	25 microns 30 GPM (114 LPM)	25 microns 30 GPM (114 LPM)	25 microns 30 GPM (114 LPM)	25 microns 30 GPM (114 LPM)
Hydraulic fluid, petroleum based (premium grade, anti- wear, non-conductive) Viscosity (at minimum and maximum operating temps)	100-400 ssu (20-82 centistokes)	100-400 ssu (20-82 centistokes)	100-400 ssu (20-82 centistokes)	100-400 ssu (20-82 centistokes)
Note: When choosing hydraulic fluid, the expected oil temperature extremes that will be experienced in service determine the most suitable temperature viscosity characteristics. Hydraulic fluids with a viscosity index over 140 will meet the requirements over a wide range of operating temperatures.				
*SSU = Saybolt Seconds Universal				

CLASSIFICATION

EHTMA HYDRAULIC SYSTEM REQUIREMENTS					
Flow range	3.5-4.3 GPM (13.5-16.5 LPM)	4.7-5.8 GPM (18-22 LPM)	7.1-8.7 GPM (27-33 LPM)	9.5-11.6 GPM (36-44 LPM)	11.8-14.5 GPM (45-55 LPM)
Nominal operating pressure (At the power supply outlet)	1870 psi (129 bar)	1500 psi (103 bar)	1500 psi (103 bar)	1500 psi (103 bar)	1500 psi (103 bar)
System relief valve setting (At the power supply outlet)	2495 psi (172 bar)	2000 psi (138 bar)	2000 psi (138 bar)	2000 psi (138 bar)	2000 psi (138 bar)

Note: These are general hydraulic system requirements. See tool specification page for tool specific requirements.

OPERATION

PREPARATION PROCEDURES

CHECK POWER SOURCE

1. Using a calibrated flowmeter and pressure gauge, make sure the hydraulic power source develops a flow of 4-6 gpm /15-22 lpm at 1500-2000 psi/105/140 bar for the CS25 or a flow of 7-9 gpm/26-34 lpm at 1000-2000 psi/70-140 bar for the CS28.
2. Make sure the power source is equipped with a relief valve set to open at 2100-2250 psi/145-155 bar.
3. Check that the dual spool valve is set to the hydraulic system type (open-center (CC) or closed-center (CC) operation).

CHECK TOOL

1. Make sure all tool accessories are correctly installed. Failure to install tool accessories properly can result in damage to the tool or personal injury.
2. There should be no signs of leaks.
3. The tool should be clean, with all fittings and fasteners tight.

CHECK TRIGGER MECHANISM

1. Check that the trigger operates smoothly and is free to travel between the **ON** and **OFF** positions.

SETTING THE DUAL SPOOL FOR OPERATION

IMPORTANT

This tool is furnished with a on-off spool commonly referred to as a “dual spool” which permits adjustment so the tool may be operated on either a open-center hydraulic system or a closed-center hydraulic system. The dual spool is normally set to the open-center (OC) position at time of manufacture. The dual spool can also be disabled so that the tool may be set to open-center only operation or closed-center only operation. For more details, please refer to the following instructions.

SETTING FOR OPEN-CENTER (OC) OR CLOSED-CENTER (CC) OPERATION

To set the tool for OC system operation turn the selector screw located in the top of the valve spool fully out (counter-clockwise) until it hits the stop.

To set the tool for CC system operation turn the selector screw located in the top of the valve spool fully in (clockwise) until it bottoms.

TO DISABLE DUAL SPOOL OPERATION AND CONVERT TO OC ONLY OPERATION

Turn the selector screw located in the top of the valve spool fully out (counter-clockwise) until it hits the stop.

1. Insert the small plug from the kit (furnished with the tool) into the hole located in the top of the selector screw. Tap the plug down using a small punch and hammer. **DO NOT USE ANY ADHESIVES.**

TO DISABLE DUAL SPOOL OPERATION AND CONVERT TO CC ONLY OPERATION

1. Turn the selector screw located in the top of the valve spool fully in (clockwise) until it bottoms.
2. Insert the small plug from the kit (furnished with the tool) into the hole located in the top of the selector screw. Tap the plug down using a small punch and hammer. **DO NOT USE ANY ADHESIVES.**

CONNECTING HOSES

1. Wipe all hose couplers with a clean lint-free cloth before making connections.
2. Connect the hoses from the hydraulic power source to the tool fittings or quick disconnects. It is a good practice to connect return hoses first and disconnect them last to minimize or avoid trapped pressure within the tool.
3. Observe the arrow on the couplers to ensure that the flow is in the proper direction. The female coupler on the tool is the inlet (pressure) coupler.
4. Move the hydraulic circuit control valve to the ON position to operate the tool.

Note: If uncoupled hoses are left in the sun, pressure increase inside the hoses can make them difficult to connect. If possible, connect the free ends of the hoses together.

OPERATION

TOOL OPERATION

! WARNING

The following are general woodcutting procedures and techniques. Differences in the terrain, vegetation and type of wood will make this information more or less valid for particular areas. For advice on specific wood cutting problems or techniques for your area, consult your local STANLEY representative or your county agent. They can often provide information that will make your work safer and more productive.

CUTTING TIPS

5. Check the lean of the tree. Tie a weight to a piece of string about 2 feet long. Hang the weight in your line of sight. The string is a good vertical line to help you judge the lean of a tree. The tree should fall the way the string is leaning. Trees that are straight (leaning no more than 5°) generally can be felled in any direction.
6. Check the weight distribution. A tree is heavier on the side with the most limbs. It will try to fall on its heavy side. Trim a few limbs to balance the tree.
7. Clear the work area. You need a clean area all around the tree. Get everything out of the area where the limbs might fall. Do not cut trees near structures. Because of the danger of electrocution, use extreme care when cutting trees near power lines.
8. The chain saw should cut with very little pressure applied to the handle. If you have to force the cut or if the cut is not straight, cease cutting immediately to prevent further saw chain and bar damage. See the Service manual for chain replacement, sharpening and adjustment procedures.

FELLING OR TOPPING

1. Observe safety precautions.

NOTCHING OR UNDERCUTTING

2. The notching or undercutting cut is made on the side you want the tree to fall.
3. Start the cut horizontally. Cut to about one-quarter of the tree's diameter.

! WARNING

Watch for falling limbs.

4. Make a diagonal cut down to meet the horizontal cut and remove the wood from the notch.

FELLING OR BACK CUT

5. The felling or back cut is made on the side opposite and at least 2 inches above the horizontal undercut (the felling cut is made higher as the size of the tree increases).
6. Start the cut horizontally parallel to the notch cut. Cut until the saw is about 1 or 2 inches from the notch. **DO NOT CUT THROUGH THE NOTCH.**

Note: The uncut wood between the felling and notch cuts is called the hinge. The hinge controls the fall of the tree and should be of uniform thickness.

7. As the saw nears the back cut, watch the tree-top and the cut for signs of movement. Be alert as soon as the tree starts to move, turn off the saw, pull it from the tree and move away quickly on your escape route.

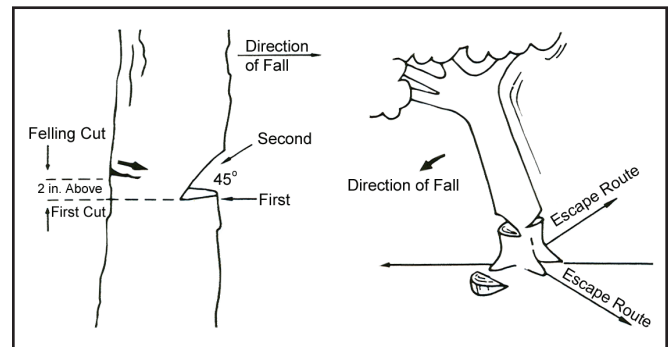

Figure 2. Felling a Tree

LOGS/LIMBS WITH PRESSURE ON BOTTOM

1. Observe all safety precautions.
2. Begin with a bottom-cut. The depth of the cut should be about one-third of the log diameter.
3. Finish with an upper cut, down from the top. The saw cuts should meet.

PRUNING & TRIMMING

1. Observe all safety precautions.
2. Use both hands. Keep a firm grip.
3. Be alert for kickback. Do not allow the tip of the bar

OPERATION

to touch anything while the chain is in motion.

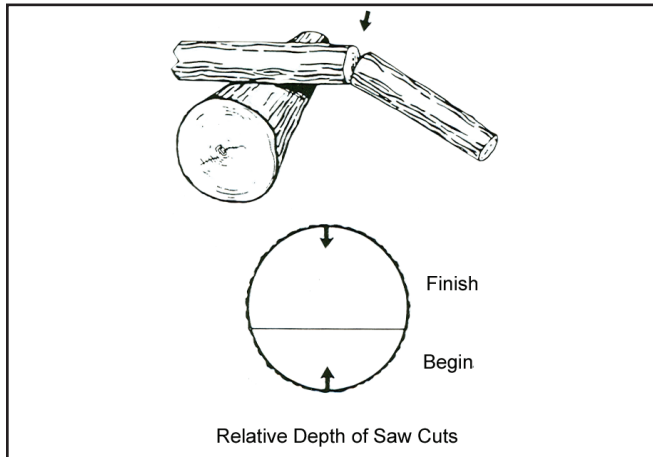

Figure 3. Crosscutting Logs/Limbs with Pressure on Bottom

4. Pole chain saws must be hung securely in a vertical position to prevent dislodgement. Pole chain saws must not be hung on utility wires or cables and must not be left in the tree overnight. Pole chain saws must be hung so the sharp edge is away from the worker, if possible.
5. Warnings, when necessary, must be given by the worker in the tree before a limb is dropped. “Timber” or “heads up” are common terms used for this purpose.
6. A separate line should be attached to limbs that cannot be dropped safely or are too heavy to be controlled by hand. The line should be held by workers on the ground end of the rope. Use of the same crotch for both the safety rope and the work rope should be avoided.
7. The safety line or climbing rope must not be used for any purpose but for climbing.
8. Cut branches must not be left in trees overnight.

TOPPING/LOWERING LIMBS

1. Observe all safety precautions.
2. Use both hands. Keep a firm grip.
3. Workers performing topping operations should make sure the trees are able to stand the strain of a topping procedure. If not, some other means of lowering the branches should be provided, such as a tree crane.
4. If large limbs are lowered in sections, the worker in the tree should be above the limb being lowered.
5. Guidelines, hand lines, or tag lines must be used

when conditions warrant their use.

LIMBING AND BUCKING

1. Observe all safety precautions.
2. Use both hands. Keep a firm grip.
3. When it is possible to do so, the tree worker must work on the side opposite the side on which the limb is being cut.
4. Branches bent under tension must be considered hazardous.

COLD WEATHER OPERATION

If the pole chain saw is to be used during cold weather, preheat the hydraulic fluid at low engine speed. When using the normally recommended fluids, fluid should be at or above 50 °F/10 °C (400 ssu/82 centistokes) before use.

Damage to the hydraulic system or pole chain saw can result from use with fluid that is too viscous or thick.

Cutting frozen wood causes the cutters to wear, crack and break at the back rivet hole unless proper precautions are taken. To extend chain life when cutting in cold weather:

- Be sure the automatic oiler is working.
- Keep the chain tensioned and check often.
- Keep the chain properly sharpened. Touch up at least every hour. Never force a dull chain to cut.
- Clean out the bar groove and keep the oil hole open. Turn the bar over to equalize wear on the rails.
- Always install a new sprocket with a new chain.

AUTOMATIC OILER ADJUSTMENT

1. Observe all safety precautions.
2. The automatic oiler is located in the front of the motor housing. The oil volume can be adjusted with a 3/16 inch Allen wrench by turning the plug counter-clockwise to increase output and turning clockwise to decrease output.

Note: Oil output varies proportionally to load and operating pressure. It should be adequate for most operations as adjusted from the factory.

3. Initial oiler adjustment is made with the saw bar and chain removed.

The following step can be hazardous. Failure to heed the instructions could result in serious injury.

4. Connect the pole chain saw to a hydraulic power source and check for proper operation. **READ THE FOLLOWING CAREFULLY BEFORE**

OPERATION

PROCEEDING.

- a. Make sure the hydraulic power source is running at the lowest gpm/lpm rate it can while still producing full pressure.
- b. Secure the pole chain saw firmly in a bench vise and place the correct size wrench on the 1/2-20 nut securing the sprocket.
- c. Connect the hydraulic power source to the pole chain saw and turn the circuit control valve to the **ON** position.
- d. With a firm grip on the pole chain saw and wrench, **SLOWLY** squeeze the trigger to activate it.
- e. Adjust the oiler for a flow of approximately one drop every one to two seconds.
- f. Release the trigger and remove the wrench.

Note: Never break in a new chain under a heavy cutting load.

10. Watch the chain tension carefully for the first half-hour of cutting.

CHAIN TENSION ADJUSTMENT

1. Observe all safety precautions.
2. When the chain appears loose, lubricate it well and let it cool for a few minutes to allow for contraction of the chain. Disconnect the pole chain saw from its hydraulic power source.

Note: Perform Steps 3 through 6 while holding the top end of the saw bar upward.

3. Loosen the two saw bar nuts slightly.
4. Tighten the chain tension screw until the bottoms of the tie straps and cutters just touch the saw bar rails of the bottom of the saw bar.
5. Pull the chain around the saw bar by hand to be sure it fits the sprocket and saw bar properly. The chain should move easily.
6. Hold the saw bar tip up as you tighten the two saw bar nuts.
7. Connect the pole chain saw to a hydraulic power source. Operate the chain at low speed (gpm) for a minute or two while pumping extra oil on the chain.
8. Stop the pole chain saw and check the tension.

If it has loosened, disconnect the pole chain saw from the hydraulic power source and perform Steps 3 through 6 again to tighten the chain to the correct tension.

9. Reconnect the pole chain saw to the hydraulic power source. Operate the saw and make a few easy cuts. Check chain tension and readjust if necessary (disconnect it from the hydraulic power source and perform Steps 3 through 6).

TOOL PROTECTION & CARE

NOTICE

In addition to the safety precautions found in this manual, observe the following for equipment protection and care.

- Make sure all couplers are wiped clean before connection.
- The hydraulic circuit control valve must be in the **OFF** position when coupling or uncoupling hydraulic tools. Failure to do so may result in damage to the quick couples and cause overheating of the hydraulic system.
- Always store the tool in a clean dry space, safe from damage or pilferage.
- Make sure the circuit **PRESSURE** hose (with male quick disconnect) is connected to the **IN** port. The circuit **RETURN** hose (with female quick disconnect) is connected to the opposite port. Do not reverse circuit flow. This can cause damage to internal seals.
- Always replace hoses, couplings and other parts with replacement parts recommended by STANLEY. Supply hoses must have a minimum working pressure rating of 2500 psi/172 bar.
- Do not exceed the rated flow. Rapid failure of the internal seals may result. See “SPECIFICATIONS” on page 19 for correct flow rate and model number.
- Always keep critical tool markings, such as warning stickers and tags, legible.
- Do not use the tool for applications it was not designed for. The chain saw is intended to cut wood only.
- Keep chain sharp for maximum tool performance.
- Tool repair should be performed by experienced personnel only.
- Make certain that the recommended relief valves are installed in the pressure side of the system.
- Do not use the tool for applications for which it was not intended.

TROUBLESHOOTING

If symptoms of poor performance develop, the following chart can be used as a guide to correct the problem.

When diagnosing faults in operation of the pole chain saw, always make sure the hydraulic power source is supplying the correct hydraulic flow and pressure as listed in the table. Use a flowmeter know to be accurate. Check the flow with the hydraulic fluid temperature at least 80 °F/27 °C.

PROBLEM	CAUSE	SOLUTION
Cuts slow.	Insufficient fluid flow or low relief valve setting.	Adjust fluid flow to proper gpm. For optimum performance adjust relief valve to 2250 psi/155 bar.
	Chain dull.	Sharpen per instructions or replace.
	Back-pressure too high.	Should not exceed 250 psi/17 bar at rated flow measured at the end of the tool operating hoses.
Bar turns color.	Insufficient oiler flow.	Adjust oiler per service instructions.
Tool does not run.	Power unit not functioning.	Check power unit for proper flow and pressure 4–6 gpm/15–22 lpm at 1500 psi/104 bar minimum for CS28. 7–9 gpm/26–34 lpm at 1000 psi/70 bar minimum for the CS25.
	Coupler or hoses blocked.	Remove obstruction.
	Mechanical failure.	Disassemble tool and inspect for damage.
Tool runs backwards.	Pressure and return hoses reversed.	Correct for proper flow direction. Motor shaft rotates clockwise.
Oil leakage around drive sprocket.	Motor shaft seal failure.	Replace as required. Make sure that oil present is not the result of excess oiler flow.
On/Off trigger is hard to press.	Pressure and return hoses reversed.	Correct for proper flow direction.
	Back-pressure too high.	Should not exceed 250 psi/17 bar at rated flow measured at the end of the tool operating hoses.
Motor sections oil leakage.	Motor face seal failure.	Replace as required.

SPECIFICATIONS

Capacity	
CS25 and CS28	12 and 15 inch/30 and 38 cm Cut Lengths
Weight (w/o Bar and Chain)	Models CS28511, CS2581106, CS28811 - 11 lbs/5 kg
.....	Models CS25112P, CS25812, CS258812 - 8 lbs/3.6 kg
Overall Length	
10 inch Bar	75 inches/190 cm
12 inch Bar	90 inches/229 cm
15 inch Bar	92 inches/234 cm
Pressure	
CS25	1500–2000 psi/105–140 bar
CS28	1000–2000 psi/70–140 bar
Flow Range	
CS25	4–6 gpm/15–22 lpm
CS28	7–9 gpm/26–34 lpm
Optimum Flow	
CS25	5 gpm/19 lpm
CS28	8 gpm/30 lpm
Porting	-8 (1/2 inch) SAE O-ring
Connect Size and Type	Adapter w/ Male
Hose Whips	No

SOUND AND VIBRATION DECLARATION	
Test conducted on CS2881101, S/N 112 operated at standard 8 gpm input	
Measured A-weighted sound power level, Lwa (ref. 1pW) in decibels	106 dBA
Uncertainty, Kwa, in decibels	3 dBA
Measured A-weighted sound pressure level, Lpa (ref. 20 µPa) at operator's position, in decibels	98 dBA
Uncertainty, Kpa, in decibels	3 dBA
Values determined according to noise test code given in ISO 15744, using the basic standard ISO 3744	
NOTE: The sum of a measured noise emission value and its associated uncertainty represents an upper boundary of the range of values which is likely to occur in measurements.	
Declared vibration emission value in accordance with EN 12096	
Measured vibration emission value: Trigger hand	1.1 m/sec ²
Measured vibration emission value: Assist hand	3.9 m/sec ²
Uncertainty: K	.5 m/sec ²
Values determined according to ISO 8662-1, ISO 5349-1,2	

ACCESSORIES

Description	Part Number
12 inch/30 cm Saw Bar.....	08347
15 inch/38 cm Saw Bar.....	07638
Saw Chain for 12 inch/30 cm Bar 34SL (56 Drive Links)	08348
Saw Chain for 15 inch/38 cm Bar 34SL (64 Drive Links)	07641
Sprocket 7T, .325 Pitch.....	07629
Chain Guard for 18 inch/46 cm Bar Length	05144
Flat File.....	11294
Scrench	11464

SERVICE TOOLS

O-ring Tool Kit.....	04337
----------------------	-------

CS25 / CS28 PARTS ILLUSTRATION

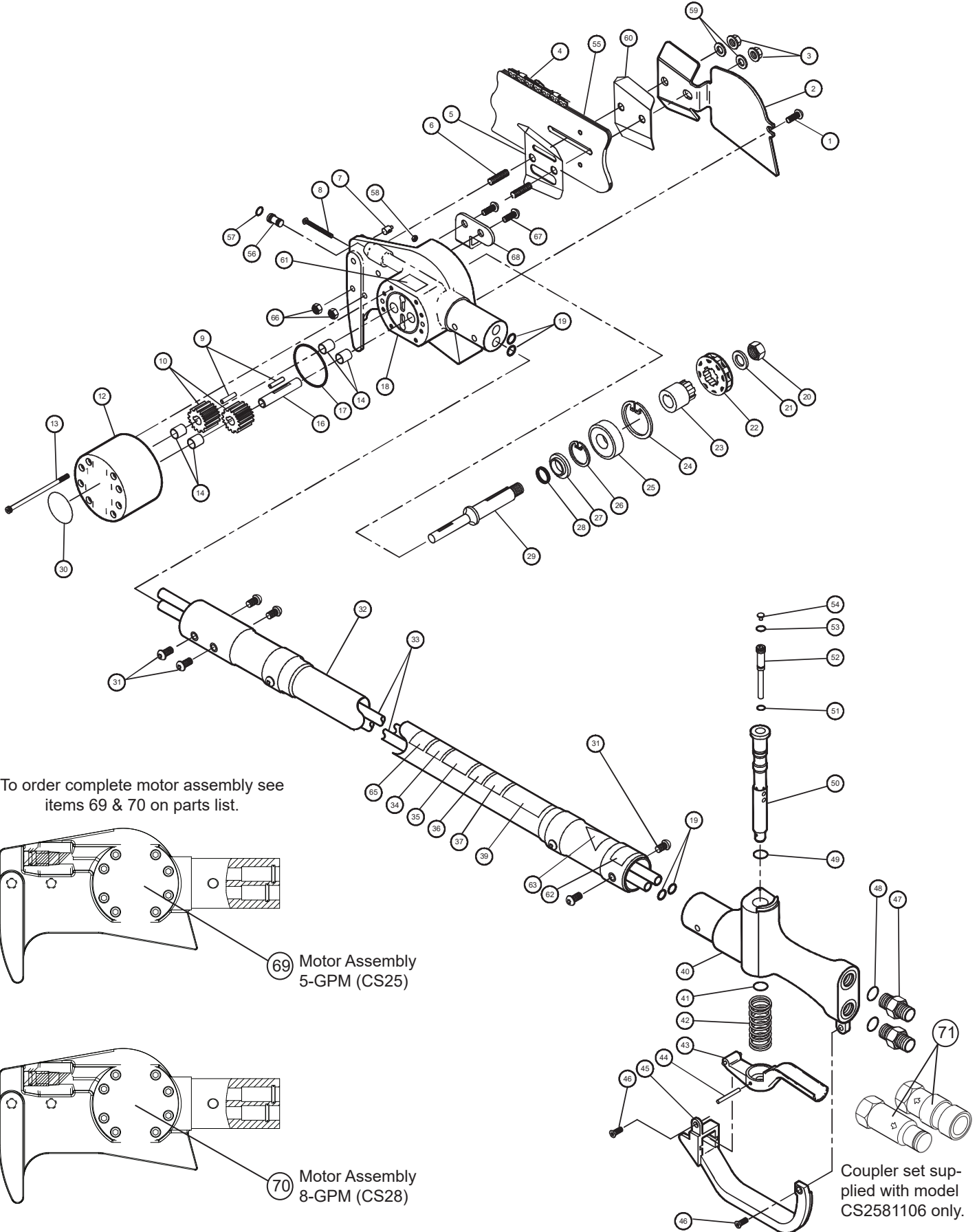

To order complete motor assembly see items 69 & 70 on parts list.

69 Motor Assembly 5-GPM (CS25)

70 Motor Assembly 8-GPM (CS28)

Coupler set supplied with model CS2581106 only.

CS25 / CS28 PARTS LIST

ITEM	PART NO.	QTY	DESCRIPTION
1	19212	1	CAPSCREW
2	76599	1	CHAIN GUARD
3	07631	2	NUT
4	08348	1	SAW CHAIN – 12 INCH
	07641	1	SAW CHAIN – 15 INCH
5	66577	1	CHAIN GUIDE PLATE
6	07630	2	STUD
7	07620	1	BAR ADJUSTMENT NUT
8	07632	1	SCREW
9	04044	2	NEEDLE ROLLER
10	04106	2	DRIVER GEAR (8 GPM)
	07832	2	DRIVER GEAR (5 GPM)
11	—	—	NO ITEM
12	07652	1	REAR GEAR HOUSING ASSY (8 GPM)
	07834	1	REAR GEAR HOUSING ASSY (5 GPM)
13	00753	8	CAPSCREW
14	04041	4	BUSHING
15	—	—	NO ITEM
16	07612	1	IDLER SHAFT
17	00020	1	O-RING*
18	66201	1	MOTOR HOUSING SERVICE ASSY
19	16668	4	O-RING*
20	00453	1	NUT
21	07617	1	WASHER
22	07629	1	RIM SPROCKET
23	07616	1	SPROCKET ADAPTER
24	06635	1	RETAINING RING
25	00335	1	BEARING
26	04856	1	RETAINING RING
27	07615	1	SEAL BACK-UP WASHER
28	04037	1	SEAL*
29	60975	1	MOTOR SHAFT
30	74752	1	NAME TAG – CS25
	74753	1	NAME TAG – CS28
31	18089	6	CAPSCREW
32	65937	1	OUTER TUBE ASSY – CS258X1
	65936	1	OUTER TUBE ASSY – CS258X2
	60973	1	OUTER TUBE ASSY – CS288X1
	62237	1	OUTER TUBE ASSY – CS288X2
33	00042	2	OIL TUBE ASSY – CS2X8X1
	62238	2	OIL TUBE ASSY – CS2X8X2
34	NA	1	DIELECTRIC TEST DECAL
35	15863	1	WARNING DECAL
36	74754	1	STANLEY DECAL
37	03786	1	7-9 GPM DECAL

ITEM	PART NO.	QTY	DESCRIPTION
	03782	1	4-6 GPM DECAL
39	12412	1	ELECTRIC WARNING DECAL
40	24833	1	HANDLE ASSY (NOTE: DOES NOT COME WITH SPOOL OR O-RING)
41	07627	1	O-RING*
42	19868	1	SPRING
43	51183	1	TRIGGER
44	01534	1	ROLL PIN
45	51182	1	TRIGGER GUARD
46	22147	2	CAPSCREW
47	00936	2	ADAPTER
48	01605	2	O-RING*
49	07626	1	O-RING*
50	19874	1	VALVE SPOOL
51	00026	1	O-RING*
52	19875	1	SELECTOR SPOOL
53	16070	1	RETAINING RING*
54	26414	1	LOCK OUT KIT
55	08347	1	SAW BAR – 12 IN
	07638	1	SAW BAR – 15 IN
56	02921	1	AUTOMATIC OILER
57	01362	1	O-RING*
58	06971	1	LOCK NUT
59	02634	2	WASHER
60	66578	1	CHAIN GUIDE
61	04746	1	AUTOMATIC OILER DECAL
66	00038	2	NUT, 8 FT. LBS. TORQUE - LOCTITE 263
67	33260	2	CAPSCREW, 4 FT. LBS. TORQUE - LOCTITE 263
68	76819	1	CHAIN CATCHER
69	73196	1	CS25 MOTOR ASSY (5-GPM) SEE NOTE BELOW
70	73195	1	CS28 MOTOR ASSY (8-GPM) SEE NOTE BELOW
71	03971	1	COUPLER SET (MALE & FEMALE)
	03693	1	CLOSED-CENTER DECAL (NOT ILLUSTRATED)
SK	21053	1	SEAL KIT

* Denotes Part in Seal Kit

Note: To order the full motor assembly which includes the following items: 6 thru 29 and 56 thru 58.

STANLEY®

STANLEY Infrastructure
6430 SE Lake Road
Portland, Oregon 97222 USA
(503) 659-5660 / Fax (503) 652-1780
www.stanleyinfrastructure.com