

# CO25 Hydraulic Cut-off Saw

34962 User Manual 2/2022 Ver. 29

**DECLARATION OF CONFORMITY  
ÜBEREINSTIMMUNGS-ERKLÄRUNG  
DECLARATION DE CONFORMITE CEE  
DECLARACION DE CONFORMIDAD  
DICHIARAZIONE DI CONFORMITÀ**

**STANLEY**  
Infrastructure  
**CE**

I, the undersigned:  
Ich, der Unterzeichnende:  
Je soussigné:  
El abajo firmante:  
Io sottoscritto:

**Nuerenberg, David**

Surname and First names/Familienname und Vornamen/Nom et prénom/Nombre y apellido/Cognome e nome

hereby declare that the equipment specified hereunder:  
**bestätige hiermit, daß erklaren Produkt genannten Werk oder Gerät:**  
**déclare que l'équipement visé ci-dessous:**  
**Por la presente declaro que el equipo se especifica a continuación:**  
**Dichiaro che le apparecchiature specificate di seguito:**

- Category: **Cut-Off-Saw, Hydraulic**  
Kategorie:  
Catégorie:  
Categoria:  
Categoria:
- Make/Marke/Marque/Marca/Marca **STANLEY**
- Type/Typ/Type/Tipo/Tipo: **CO2554101, CO2514101**
- Serial number of equipment:  
Seriennummer des Geräts:  
Numéro de série de l'équipement:  
Numero de serie del equipo:  
Matricola dell'attrezzatura: **All**

**Has been manufactured in conformity with  
Wurde hergestellt in Übereinstimmung mit  
Est fabriqué conformément  
Ha sido fabricado de acuerdo con  
E' stata costruita in conformità con**

Directive/Standards Richtlinie/Standards Directives/Normes Directriz/Los Normas Direttiva/Norme	No. Nr Numéro No n.	Approved body Prüfung durch Organisme agréé Aprobado Collaudato
EN ISO	3744 (15744)	Self
EN ISO	20643	Self
Machinery Directive	2006/42/EC	Self
EN ISO	11148-12, Cl. 5.5	Self
EN ISO	11148-12, Cl. 5.6	Self
EN ISO	13732-1	Self

- Special Provisions: **None**  
Spezielle Bestimmungen:  
Dispositions particulières:  
Provisiones especiales:  
Disposizioni speciali:
- Representative in the Union: **Patrick Vervier, Stanley Dubuis 17-19, rue Jules Berthonneau-BP 3406 41034 Blois Cedex, France.**  
Vertreter in der Union/Représentant dans l'union/Representante en la Union/Rappresentante presso l'Unione

Done at/Ort/Fait à/Dado en/Fatto a STANLEY Infrastructure, Milwaukie, Oregon, USA Date/Datum/le/Fecha/Data 4-27-2018

Signature/Unterschrift/Signature/Firma/Firma

*David Nuerenberg*  
North America Quality Manager

Position/Position/Fonction/Cargo/Posizione

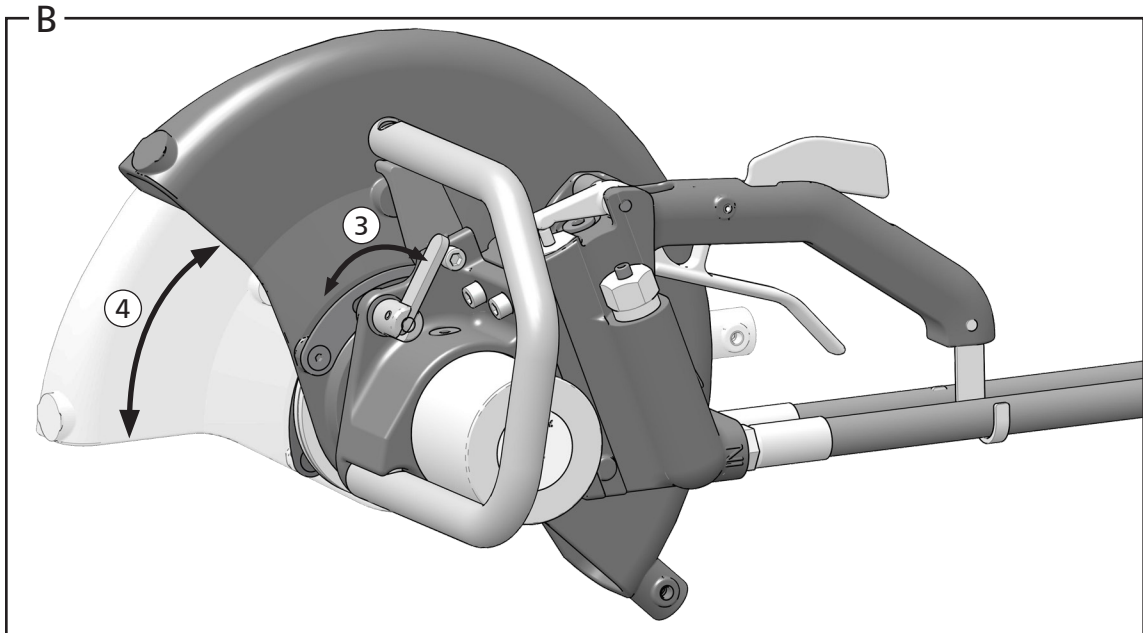
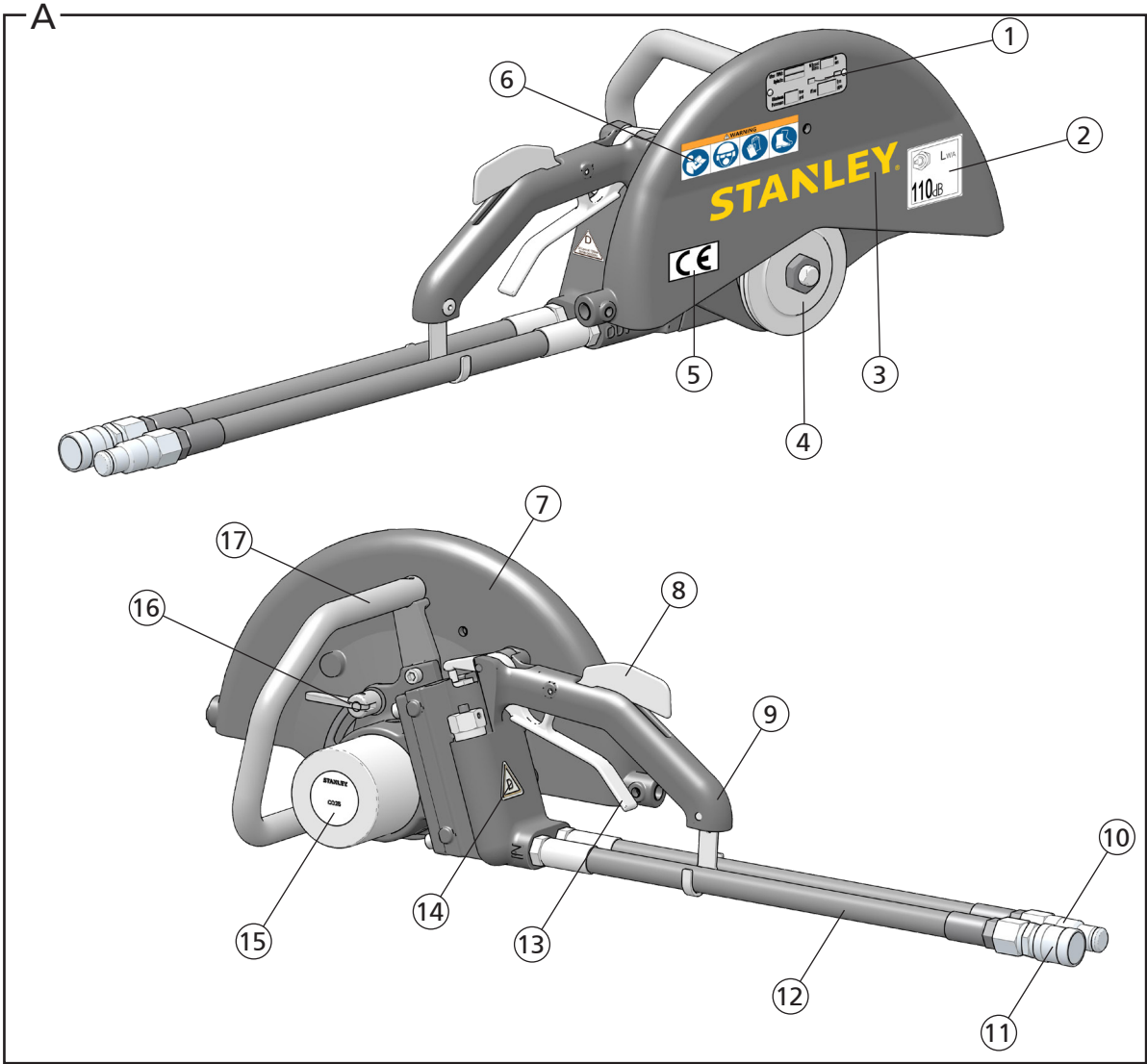

C

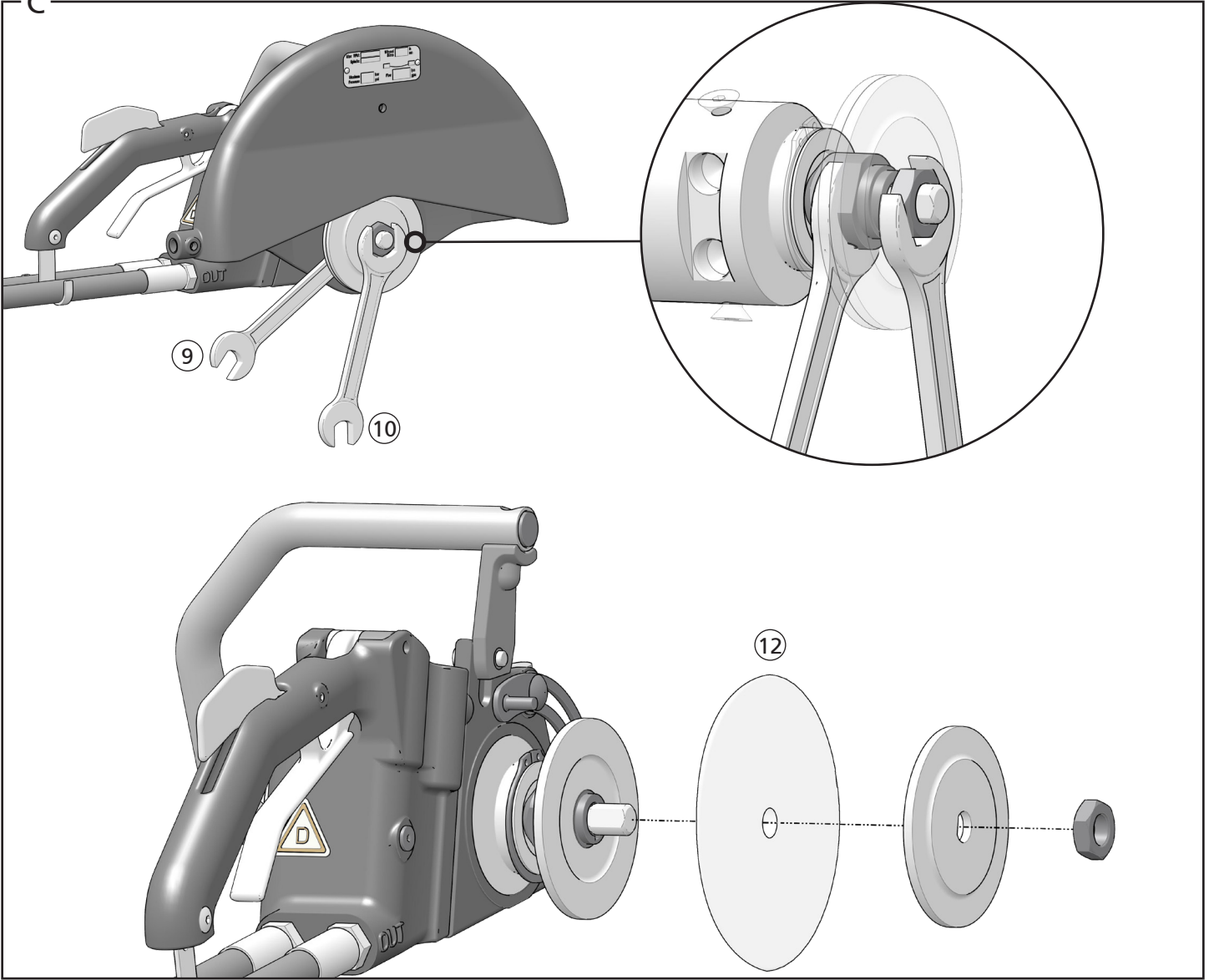

D

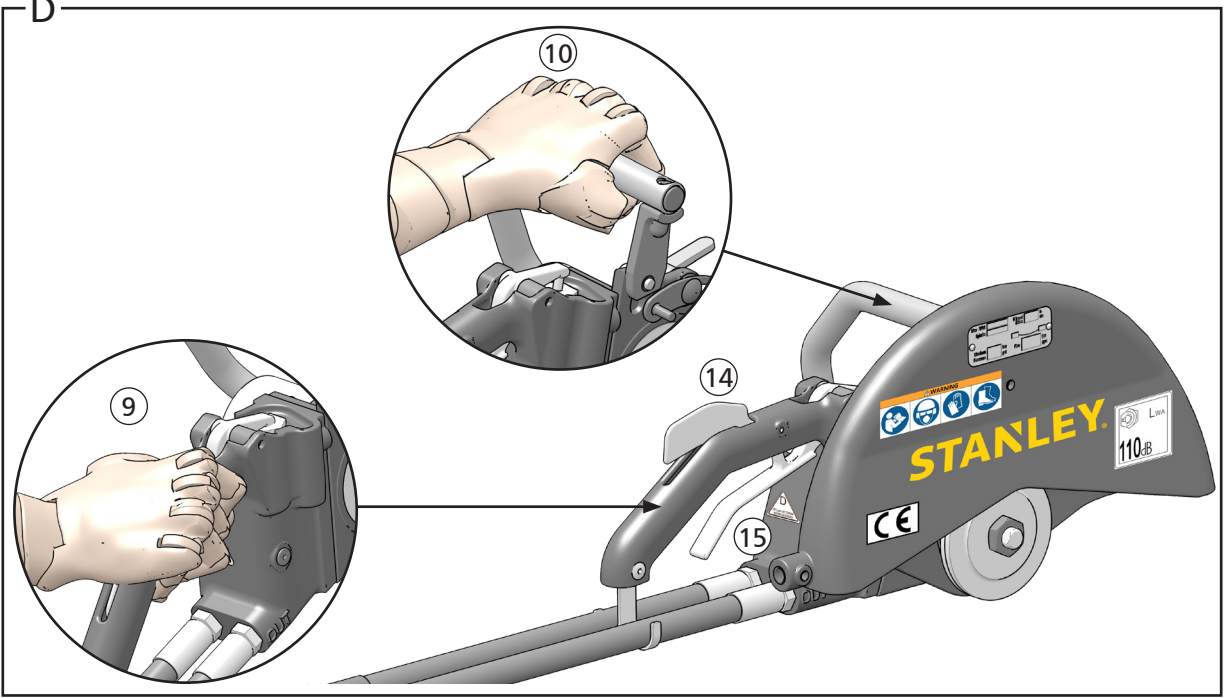

E

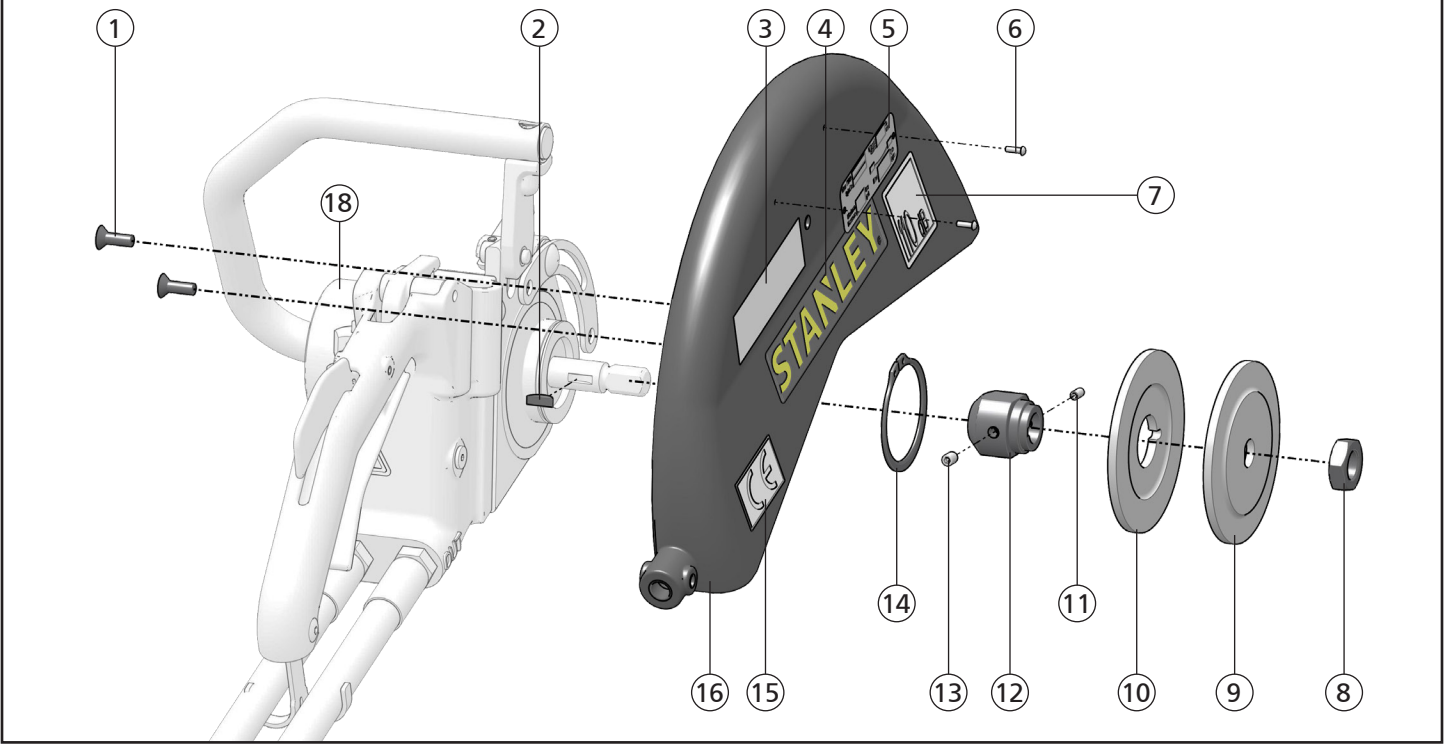

F

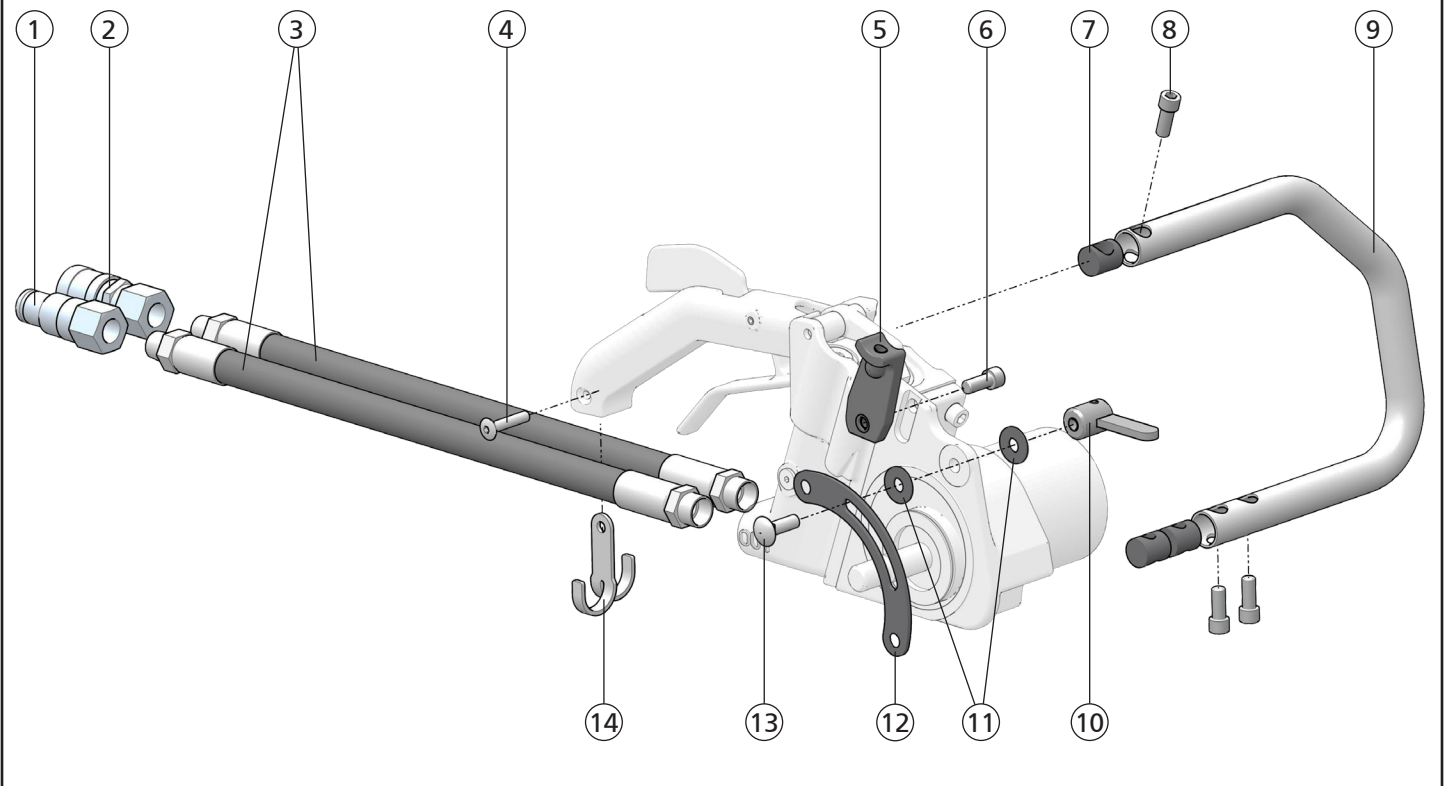

G

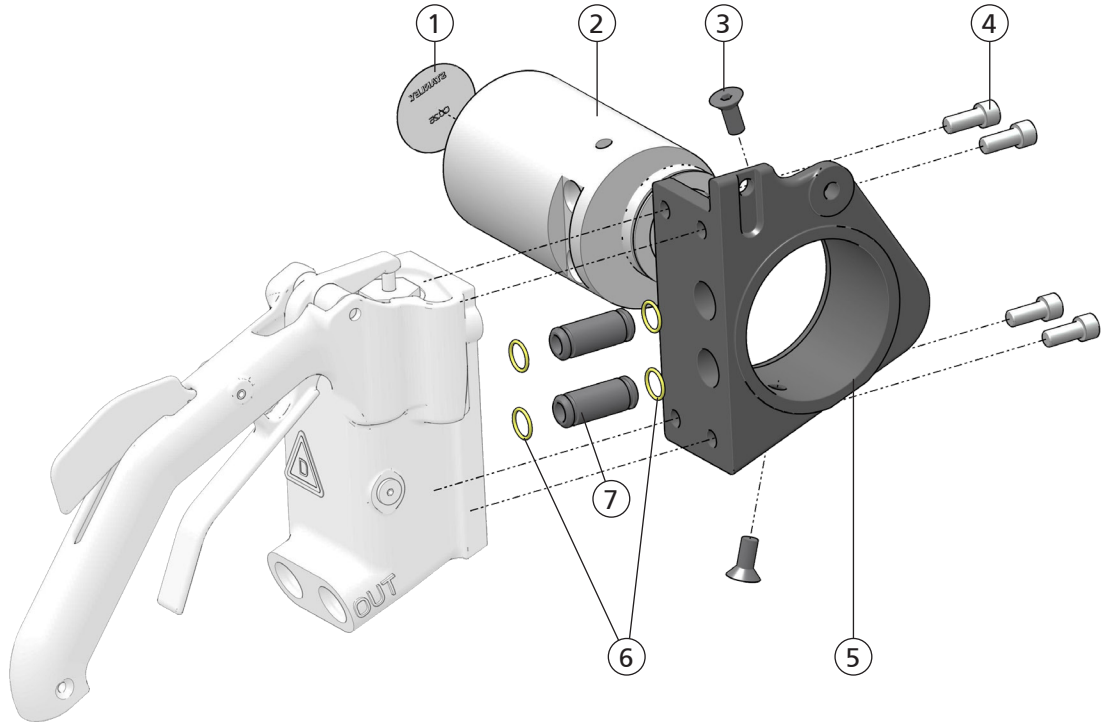

H

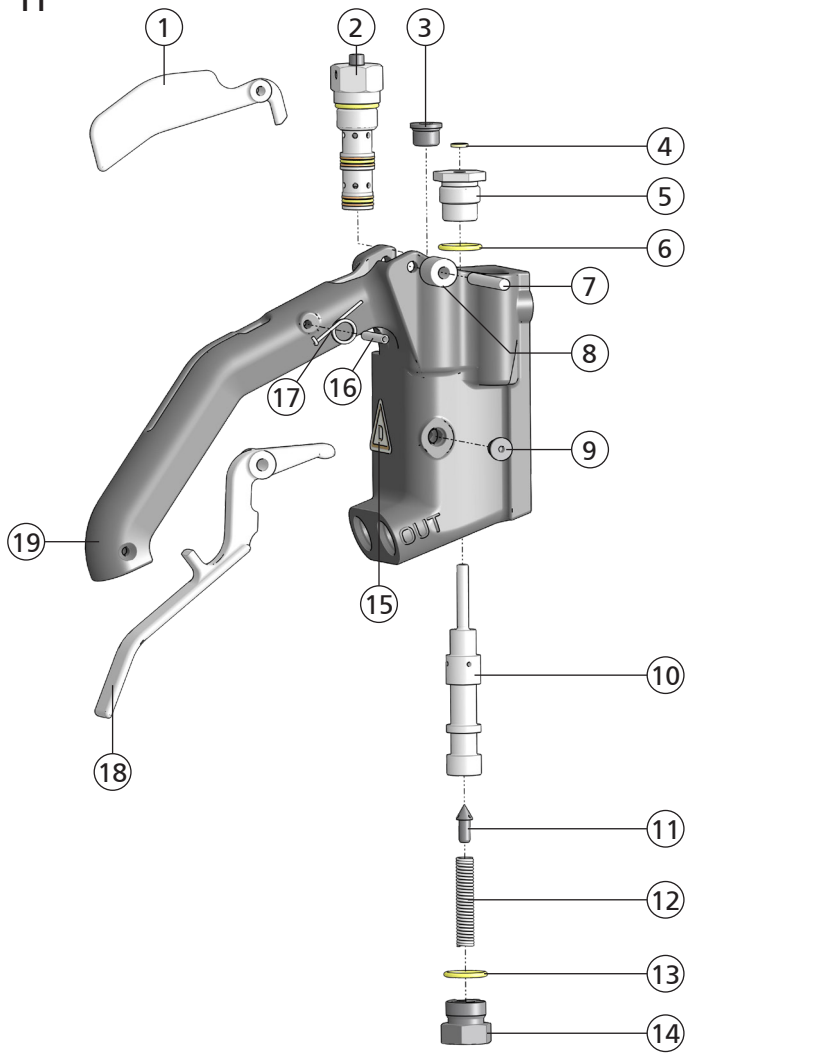

CO25 Wheel Guard & Retainer Illustration - Detail E		
ITEM	P/N	DESCRIPTION
1	05071	Cap Screw - Loctite 243
2	00772	Woodruff Key
3	88349	Composite Safety Decal
4	74770	STANLEY Logo Decal
5	76610	Tool Information Plaque
6	02004	Screw
7	81434	Sound Power Level Decal
8	01714	Jam Nut
	03012	Jam Nut - Models CO2554101, CO25541
9	62291	Outside Collar
10	62290	Inside Collar
11	00563	Roll Pin
12	04673	Thrust Collar
13	00720	Set Screw
14	03013	Retaining Ring
15	28322	CE Decal
16	32436	Wheel Guard
17	31845	Seal Kit (not shown) - *In seal kit
18	88345	Importer Decal

CO25 Assist Handle and Hose Illustration - Detail F		
ITEM	P/N	DESCRIPTION
1	03973	Male Coupler
2	03972	Female Coupler
3	56725	Hose
4	35963	Screw
5	20461	Handle Strut
6	02688	Cap Screw
7	02649	Handle Bar Retainer
8	02688	Cap Screw
9	02654	Assist Handle
10	03050	Guard Adjustment Knob Assembly
11	01594	Washer
12	32445	Guard Clamp
13	03025	Carriage Bolt
14	02911	Hose Clip
15	31845	Seal Kit (not shown) - *In seal kit





CO25 Motor Assembly - Detail G		
ITEM	P/N	DESCRIPTION
1	74823	Tool Name Tag
2	73441	Motor
	73440	Motor - Models CO25541, CO2554101
If resealing the motor, torque motor bolts to 15-17 ft. lbs. (20-23 Nm).		
3	03006	Cap Screw
4	02688	Cap Screw

CO25 Motor Assembly - Detail G		
ITEM	P/N	DESCRIPTION
5	02950	Motor Housing
6	00175	O-ring*
7	02912	Oil Tube
8	31845	Seal Kit (not shown) - *In seal kit

CO25 Trigger Handle Illustration- Detail H		
ITEM	P/N	DESCRIPTION
1	22704	Trigger Lock
2	31854	Flow Regulator Cartridge
3	08104	Hex Plug
4	00112	O-ring*
5	02931	On-Off Valve Cap
6	01604	O-ring*
7	17681	Spring Pin
8	02920	Spacer
9	350023	Hex Plug
10	32026	Valve Spool
	31138	Valve Spool - Models CO25541, CO2554101
11	31186	Poppet
12	02916	Spring
13	01604	O-ring*
14	31137	Plug
15	11207	Circuit Type "D" Decal - Models CO2514101, CO2554101
	09612	General Caution Decal - Models CO25141, CO25141D, CO25541
16	17668	Roll Pin
17	22701	Spring
18	22707	Trigger
19	28552	Valve Handle
20	31845	Seal Kit (not shown) - *In seal kit



## Safety Precautions

	The Safety Alert Symbol alerts you to potential personal injury hazards. Obey all safety messages that follow to avoid possible injury or death.
 <b>DANGER</b>	Indicates an imminently hazardous situation which will result in death or serious injury.
 <b>WARNING</b>	Indicates a potentially hazardous situation which could result in death or serious injury.
 <b>CAUTION</b>	Indicates a potentially hazardous situation which could result in property damage.

Always observe safety symbols. They are included for your safety and for the protection of the tool.



**WARNING:** Read all safety warnings and instructions. Failure to follow warnings and instructions may result in tool damage and/or serious injury.

**WARNING:** To reduce the risk of injury, read the instruction manual.

## General

- Do not discard safety instructions. Give to the operator.
- This tool will provide dependable service if operated in accordance with the instructions given in this manual. Read and understand this manual and any stickers and tags attached to the tool and hoses before operation. Failure to do so could result in personal injury or equipment damage.
- Inspect the tool before each use and ensure all decals are legible. Contact STANLEY if replacements are needed.
- Establish a training program for all operators to ensure safe operation. Do not operate the tool unless thoroughly trained or under the supervision of an instructor. Keep out of the reach of children.
- Operators and maintenance personnel shall be able to physically handle the bulk, weight and power of the tool.
- Avoid unsuitable postures as these positions do not allow for counteracting of normal or unexpected movement of the tool, such as a sudden break of the tool bit. Change postures during extended tasks to help avoid discomfort or fatigue.
- Do not operate a damaged, improperly adjusted, modified or incompletely assembled tool.
- Do not operate the tool in explosive atmospheres, such as in the presence of flammable liquids, gases or dust. Power tools create sparks which may ignite the dust or fumes.
- Do not grind on vessels containing combustible substances.
- Never cause sparks in the vicinity of flammable materials.
- Provide adequate ventilation in closed areas when operating a gas or diesel hydraulic power source.
- Do not inspect, carry, clean, change accessories or perform maintenance on the tool while the power source is connected.
- Accidental engagement of the tool can cause serious injury.
- Prevent unintentional starting. Ensure the trigger is in the off position before connecting to the hydraulic power source, picking up or carrying the tool. Carrying tools with your finger on the trigger or energizing tools that have the trigger on invites accidents.
- Ensure the grinding wheel is stopped when setting down the tool. Never transport or store the tool with a grinding wheel installed.
- Ensure that the abrasive wheel is properly clamped before each use. Follow all instructions.
- Ensure work piece is securely fixed. Be aware that failure of the work piece or accessories may generate high velocity projectiles.
- Stay alert, watch what you are doing and use common sense when operating a hydraulic tool. Do not operate this tool if you are tired or under the influence of drugs or alcohol. A moment of inattention while operating hydraulic tools may result in serious injury.
- Assess risks to others around you before operating the tool.
- Use and maintain the tool as stated in this manual. Misuse of the tool can cause serious injury. Do not modify the tool in any way.
- Keep all body parts away from rotating components of the tool. Avoid direct contact with the tool as it may become hot.
- Do not start the tool if the grinding wheel is touching a surface.
- Supervising personnel should develop additional precautions relating to

the specific work area and local safety regulations.

- Never operate the tool if you cannot be sure that underground utilities are not present, such as electrical cables, gas pipes, etc. These can cause a hazard if damaged with the tool.
- The tool is not insulated against coming into contact with electric power. Use hose certified as non-conductive.
- Do not overreach. Maintain proper footing and balance at all times when using the tool. Do not start grinding until the work area is clear and you have secure footing.
- Do not reverse tool rotation direction by changing hydraulic fluid flow direction.
- Slips, trips and falls are major causes of workplace injury. Be observant of hoses or oily surfaces lying about the work area, as they can be a tripping hazard.
- Operator must start in a work area without bystanders and must assess the risk to bystanders.
- Keep work area clean and well lit. Cluttered or dark areas invite accidents.
- Operators must be familiar with all prohibited work areas such as excessive slopes and dangerous terrain conditions.
- Only use clean hydraulic fluid and lubricants that have been recommended by STANLEY.
- Ensure tools are working properly and safely by performing preventative maintenance (PM) procedures.
- Repair and service of this tool must only be performed by an authorized and certified dealer.
- Use only replacement parts recommended by STANLEY.
- Do not force the tool to do the work of a larger tool. Use the correct tool for your application. Any use of this tool, outside those stated in this manual, are forbidden.
- Use only hoses and hose couplings that are rated for a minimum working pressure of 2500 PSI (172 BAR).
- Keep tool handles dry, clean and free from oil and grease. This will enable better control of the tool.
- In spite of the application of relevant safety regulations and the implementation of safety devices, certain residual risks cannot be avoided. These risks are: repetitive strain injury due to improper posture while using the tool and the risk of pinching fingers when pulling the tool trigger.

## Dust and Fumes

- **WARNING:** Some dust created by power sanding, sawing, grinding, drilling, and other construction activities contains chemicals known to the State of California to cause cancer, birth defects or other reproductive harm. Some examples of these chemicals are:
    - Lead from lead-based paints,
    - crystalline silica from bricks and cement and other masonry products, and
    - arsenic and chromium from chemically-treated lumber.
- Your risk from these exposures varies, depending on how often you do this type of work. To reduce your exposure to these chemicals: work in a well ventilated area, and work with approved safety equipment, such as those dust masks that are specially designed to filter out microscopic particles.
- Protect yourself and those around you. Research and understand the materials you are grinding. Follow correct safety procedures and comply with all applicable national, state or provisional health and safety regulations relating to them, including, if appropriate arranging for the safe disposal of the materials by a qualified person.
- Working with certain materials may create emissions of dust and fumes, causing a potentially explosive environment. Take precautions.
  - When dust or fumes are created, control them at the point of emission. Direct tool exhaust to minimize disturbance of dust.
  - Operate and maintain the tool as recommended in this manual to minimize dust or fume emissions.
  - Use respiratory protection in accordance with employers instruction or as required by occupational health and safety regulations.
  - Avoid prolonged contact with dust. Allowing dust to get into your mouth, eyes or lay on the skin may promote absorption of harmful chemicals.
  - Select and replace accessories as recommended in order to prevent an unnecessary increase in dust or fumes.
  - Do not use the tool on asbestos.

## PPE

- Always wear safety equipment such as impact resistant goggles, ear protection, head protection, breathing protection and safety shoes at all times when operating the tool.
- Hands may be exposed to hazards, impacts, cuts, abrasions and heat. Wear gloves.
- Grinding sparks can ignite clothing and cause severe burns. Ensure sparks do not land on clothing. Wear fire-retardant clothing and have a bucket of water nearby.
- Wear a hardhat if performing overhead work.
- Use PPE that conforms to standards ANSI Z87.1 (Eye and Face Protection), ANSI Z89.1 (Head Protection), ANSI Z41.1 (Foot Protection) and ANSI S12.6 (S3.19) (Hearing Protection).
- Do not wear loose fitting clothing, jewelry or gloves with cut or frayed fingers when operating the tool. Entanglement, choking, scalping and laceration can occur if loose clothing, personal jewelry, neck wear, hair or gloves are not kept away from the rotating tool and it's accessories.



M003  
Wear Ear  
Protection



M004  
Wear Eye  
Protection



M016  
Wear a Mask

## Sound

- Exposure to high noise levels can cause permanent, disabling hearing loss and other problems, such as tinnitus (ringing, buzzing, whistling or humming in the ears). Use hearing protection in accordance with employer's instructions and as required by occupational health and safety regulations. Appropriate controls to reduce the risk can include actions such as damping materials to prevent work pieces from "ringing".
- Use and maintain as recommended in the manual to prevent an unnecessary increase in noise levels.

## Vibration

- When using a rotary tool to perform work related activities, the operator can experience discomfort in the hands, arms, shoulders, neck or other parts of the body.
- If you experience numbness, tingling, pain or whitening of the skin in your fingers or hands, stop using the tool. Tell your employer and consult a physician.
- Wear warm clothing when working in cold conditions and keep your hands warm and dry.
- Exposure to vibration can cause disabling damage to the nerves and blood supply of the hands and arms.
- Use and maintain as recommended in the manual to prevent an unnecessary increase in vibration.
- Do not allow the abrasive product to chatter on the work piece as this is likely to cause a substantial increase in vibration.
- Check the vibration level after each service. If higher than normal, contact your STANLEY dealer.

## Hydraulic

- **Warning:** Hydraulic fluid under pressure could cause skin injection injury. Do not check for leaks with your hands. If you are injured by hydraulic fluid, get medical attention immediately.
- Do not let hydraulic oil get on the skin. Hydraulic oil is hot. Wear Personal Protection Equipment (PPE) at all times.
- If exposed to hydraulic fluid, wash hands immediately.
- Do not exceed the maximum relief valve setting stated on the tool.
- Inspect and clean couplers before use, daily. Replace damaged couplers immediately.
- Hydraulic circuit control valve must be OFF before coupling or uncoupling tools. Failure to do so may damage the couplers and cause overheating of the hydraulic system.
- Ensure the couplers are properly connected and are tight.
- Do not operate the tool at fluid temperatures above 140°F (60°C). Higher temperatures can cause operator discomfort and damage to the

tool.

- Do not exceed the rated flow and pressure as stated on the tool. Rapid failure of the internal seals may result.



## What is a CO25 Hydraulic Cut-off Saw

CO25 is a lightweight, powerful cut-off saw for cutting concrete, masonry, pipe, structural steel beams and guardrail. CO25 requires an external hydraulic power supply capable of supplying 7-9 GPM @ 1500-2500 PSI.

Specifications	
Pressure	1500-2500 PSI
Flow	7-9 GPM
Max. Pressure	2500 PSI
Max. Relief Pressure	2250 PSI
Recommended Back Pressure	250 PSI (17 BAR) - Can be used with higher back pressures with reduced seal life.
Couplers	3/8 inch male pipe hose end
Port Size	-8 SAE O-ring
Wheel Capacity	14 inch
Max. Spindle Speed	4500 RPM
Tool Weight	20 Lbs (9 kg)
Tool Length	21 inches (53 cm)
Width (at handles)	11 inches (28 cm)
Max. Hydraulic Oil Temp.	140°F (60°C)
HTMA/EHTMA Category	Type II, Category D

Sound & Vibration Declaration	
Measured A-Weighted sound power level	109.4 dBA
Measured A-Weighted Sound Pressure	101.5 dBA
Uncertainty	0.03 dBA
Values determined according to noise test code given in ISO 15744, using the basic standard ISO 3744. Test conducted by independent notified body to comply with 2000/14/EC:2005.	
Measured Vibration Emission Value: 3-Axis - Trigger Handle	4.9 m/sec <sup>2</sup>
Measured Vibration Emission Value: 3-Axis - Assist Handle	4.2 m/sec <sup>2</sup>
Uncertainty	1.0 m/sec <sup>2</sup>

## Parts of a CO25 - Detail A

1	Tool Information Plaque
2	Sound Power Level Decal
3	STANLEY Logo Decal
4	Grinding Wheel Retainer
5	CE Decal
6	Composite Warning Decal
7	Wheel Guard
8	Trigger Lock
9	Tool Handle
10	Male Hydraulic Coupler
11	Female Hydraulic Coupler
12	Hose Whips
13	Trigger
14	Circuit Type "D" Decal
15	Tool Name Tag
16	Wheel Guard Adjustment Lever
17	Assist Handle

## Tool Setup

### **⚠ WARNING**

Do not install or change tool accessories while the hydraulic power source is connected. Accidental engagement of the tool can cause serious injury. Disconnect the hydraulic power source and put the direction control in neutral before installing or changing accessories.

1. Power down the hydraulic power supply and disconnect from the tool.

### Adjust the Wheel Guard - Detail B

### **⚠ WARNING**

Do not operate the tool with the wheel guard removed. Serious injury can occur. Ensure the wheel guard is properly secured before using the tool.

2. Inspect the wheel guard for damage. Replace before using.
3. Loosen the guard adjustment knob.
4. Adjust the wheel guard so that it is between the user and the cutting wheel. This will keep cutting sparks and debris away from the user.
5. Tighten the guard adjustment knob.

### Install the Cutting Wheel - Detail C

### **⚠ WARNING**

Use cutting wheels designed for use on hand-held cut-off tools. Personal injury can occur if using cutting wheels not intended for hand-held cut-off tools.

6. Only use cutting wheels that comply with ANSI B7.5 / ISO 525,603.
7. Ensure that the maximum operating speed of the cutting wheel is equal or greater than the rated speed of the tool shaft (see "Specifications" on page 9).

Note: If wet cutting, ensure the cutting wheel is suitable for wet cutting. Follow the cutting wheel manufacturers recommendations.

8. Inspect the cutting wheel for cracks, distortion of shape, unbalance or damage. Replace the cutting wheel immediately if it displays any of these signs of damage.

Note: If the tool is dropped with the cutting wheel installed, thoroughly inspect the wheel for damage before use. Replace if damaged.

9. Place a wrench on the thrust collar, behind the inside collar.
10. Place another wrench on the collar jam nut.
11. Remove the outside collar.
12. Install the cutting wheel the to spindle, between the inside and outside collars.
13. Replace the outside collar and tighten the jam nut enough to prevent the cutting wheel from slipping during use.
14. Remove the wrenches.

### **⚠ WARNING**

Remove any adjusting key or wrench before turning the tool on. A wrench or a key left attached to a rotating part of the tool may result in personal injury.

## Tool Operation - Detail D

### Connect to a Hydraulic Power Source

1. Using a calibrated flow and pressure gauge, check the output of the hydraulic power source. Ensure it matches the flow and pressure in "Specifications" on page 9. Hydraulic fluid must be 50°F or above. Preheat if necessary.

2. Ensure that the hydraulic power source is equipped with a relief valve set to open at the maximum relief pressure (see "Specifications" on page 9).
3. Wipe hose couplers with a clean, lint free cloth.
4. Connect the return hose to the male coupler.
5. Connect the pressure hose to the female coupler.
6. Ensure couplers are undamaged, properly connected and are tight.
7. Ensure the tool trigger is not engaged.
8. Power up the hydraulic power supply.

#### Testing the Tool

9. Wrap your right hand around the trigger handle.
10. Wrap your left hand around the assist handle.
11. Stand in the back of the tool.
12. Hold the tool with a light, but safe, grip taking account of the required hand-reaction forces, because the risk from vibration is generally greater when the grip force is higher.

Note: Hold the tool correctly and be ready to counteract normal or sudden movements. Have both hands available.

13. Lift the tool, holding the cutting wheel away from you.
14. Hold down the trigger lock.
15. Slowly hold down the trigger.
16. Run the tool for at least one minute. Ensure the tool is running properly. If considerable vibration or other defects are detected, stop operation immediately. Contact your STANLEY dealer for service.
17. Release the trigger.

Note: Do not operate the tool if the wheel does not stop when the trigger is released. Contact your STANLEY dealer for service.

#### Using the Tool

18. Clamp down the work piece. Ensure it is supported on both sides of the cut.
19. If wet cutting, turn on the water supply.
20. Hold down the trigger lock and slowly hold down the trigger.

Note: Do not start the saw with the wheel on the surface of the work piece. The tool could pull or climb on the work piece.

21. Start cutting and apply gentle, consistent pressure.
22. Feed the wheel through the material as fast as possible, without slowing the rotation speed. Always use full throttle when cutting.

Note: Cutting too slowly causes heat expansion and can result in the cutting wheel binding in the material. This is a common cause of cutting wheel breakage.

23. While cutting, do not jam the wheel or use the side of the wheel as a cutting surface. This can cause saw kickback.
24. Release the trigger
25. If wet cutting, shut off the water supply.

Note: If you encounter a breakdown or the tool stops for any reason, release the trigger and power down the hydraulic power source.

## Tool Maintenance

### **⚠️ WARNING**

Do not perform maintenance on the tool while the hydraulic power source is connected. Accidental engagement of the tool can cause serious injury. Disconnect the hydraulic power source and put the direction control in neutral before servicing.

Use only accessories, consumables and parts recommended by STANLEY.

#### Daily Maintenance

1. Remove hydraulic power from the tool and check all hydraulic connections and hoses for damage. Replace damaged parts before operating the tool.
2. Inspect tool to ensure all stickers are legible. Contact STANLEY if replacements are needed.
3. Inspect the cutting wheel and wheel guard for damage. Replace damaged parts before attempting to use the tool.
4. Inspect the assist handle and ensure it is securely fastened and is free of oil or liquids.
5. Inspect the trigger lock and ensure it is working properly.

6. Inspect the thrust collars for damage. Replace if damaged.
7. Check the flow and pressure of the hydraulic power source using a calibrated flow meter. Proper flow and pressure maintain proper tool speed. If tool speed increases or decreases, stop using the tool and ensure proper flow and pressure.

#### Every 100 Operation Hours

The speed of the drive shaft and the bearings must be checked every 100 hours. Contact your STANLEY dealer to perform this service.

Note: Do not use the tool at speeds greater than it's rated maximum speed or speeds greater than the maximum speed marked on the cutting wheel.

## Tool Storage & Transport

#### Storage

Plug open hydraulic ports. Clean the tool and store in a clean, dry space that is safe from damage.

#### Cutting Wheel Storage

- Remove the wheel from the tool. Do not store or transport the tool with the wheel installed.
- Clean wheels to remove any dirt, debris or grease and dry thoroughly.
- Inspect the wheel for chips, cracks or damage. Replace the wheel if its worn or damaged.
- If wheels are supplied with blotters attached, insert suitable separators between each wheel and the supporting surface to preserve flatness.
- Store wheels on a flat surface of steel or similar rigid material.
- Do not store wheels where they will be exposed to high humidity, liquids, excessive heat or freezing temperatures.

#### Transport

Never transport tool with the hydraulic power supply connected. Secure the tool to the transport vehicle. Lift only as high as necessary to load. NEVER lift or transport over people. Ensure tool is secured and will not move during transport. An unsecured tool could cause personal injury or damage to the tool.

## Tool Disposal

#### Hydraulic Oil

Hydraulic oil can contaminate the air, ground and water if not properly recycled. Recycle hydraulic oil in accordance with all State, Federal and local laws, at your local oil recycling facility.

#### Hydraulic Hoses

Hang hydraulic hoses to drain. Collect the oil for recycling. Contact your local municipal recycling authorities for an approved hydraulic hose recycling site.

#### Tool Body

Drain hydraulic oil from the tool, making sure to collect the oil for recycling. Disassemble the tool and dispose of all non-metal parts. Recycle the metal components. Contact your local municipal recycling authorities for recycling instructions.

## Accessories

Description	Part Number
14 inch Abrasive Wheel w/ 1 inch Arbor - Metal	02691
14 inch Abrasive Wheel w/ 1 inch Arbor - Masonry	02692
14 inch Diamond Blade - Dry Cut	62358
Handle Extension Kit	34175
Water Attachment Kit	33228
Includes (1) 33220 Water Hose, (1) 33226 Tube, (1) 33227 Tube, (1) 35196 Brass Adapter, (3) 33223 Hose Barb, (1) 35197 Elbow.	

## Troubleshooting

Problem	Possible Cause	Solution
Tool does not operate properly.	The hydraulic power supply is turned Off.	Ensure the power source delivers proper flow and pressure. "Specifications" on page 9.
	Hydraulic hoses are not connected properly.	Power down the hydraulic power supply. Check the couplers and ensure they are tight and properly installed. "Specifications" on page 9.
	Excessive back pressure	Ensure back pressure is not greater than specified in "Specifications" on page 9.
	Mechanical Failure	Contact your STANLEY dealer for service.
Tool cuts too slowly	Using the wrong cutting wheel.	Ensure you are using the proper cutting wheel for your application.
	Insufficient oil flow	Ensure the power source delivers proper flow and pressure. See "Specifications" on page 9.
Hydraulic oil leaks between the motor housing and the valve handle.	Oil tube o-ring failure or motor face seal failure.	Contact your STANLEY dealer for service

# STANLEY®

STANLEY Infrastructure  
6430 SE Lake Road, Portland, Oregon 97222 USA  
(503) 659-5660 / Fax (503) 652-1780  
[www.stanleyinfrastructure.com](http://www.stanleyinfrastructure.com)