

# CH15 PARTS ILLUSTRATION

Note: If you have a 5-GPM CH15 tool, the 3 parts that are required to make it a 5-GPM tool are no-longer available as of July 2015. If you need to replace any one of items 29, 31 or 32 you must purchase all 3 items to convert the tool to an 8-GPM tool, the tool will still work at 5-GPM if needed.

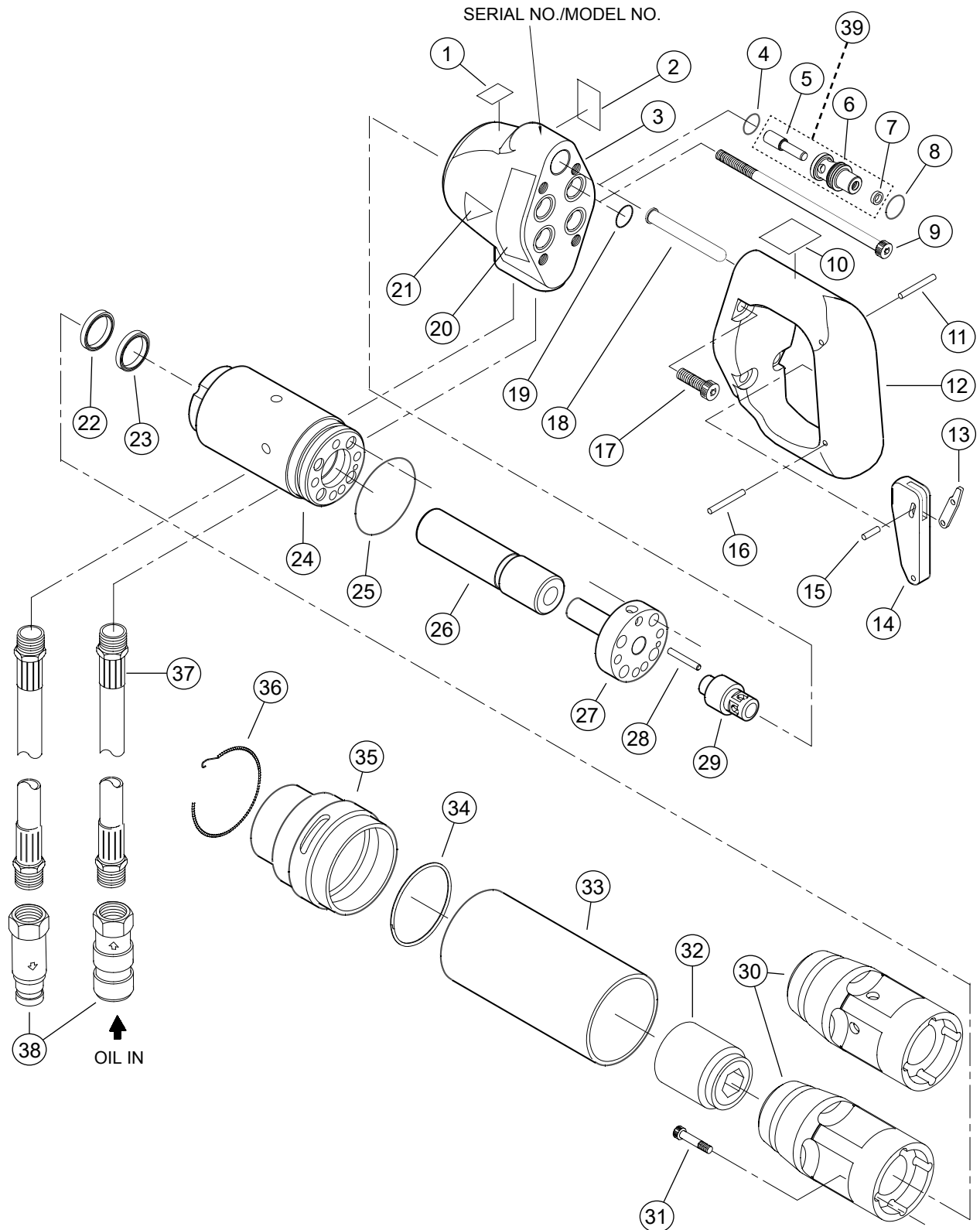

# CH15 PARTS LIST

ITEM	P/N	QTY	DESCRIPTION
1	28323	1	CE STICKER
2	66654	1	SOUND PWR LEVEL STICKER
3	73310	1	BODY
4	00016	1	O-RING * Δ
5	81110	1	VALVE SPOOL
6	81111	1	VALVE SLEEVE
7	81109	1	CUP SEAL Δ
8	01211	1	O-RING * Δ
9	24871	4	CAPSCREW 5/16-18UNC × 3
10	28409	1	COMPOSITE STICKER
11	07492	1	SPIROL PIN
12	62209	1	HANDLE
13	62197	1	TRIGGER ROD
14	62198	1	TRIGGER
15	00878	1	DOWEL PIN, 3/16 × 1/2 SS
16	31602	1	SPIROL PIN 5/32 × 1.2
17	13815	4	CAPSCREW 5/16-18UNC × 1
18	31582	1	TRIGGER PIN
19	01211	4	O-RING * Δ
20	36112	1	NAME TAG
21	11207	1	CIRCUIT "D" DECAL
22	31607	1	SCRAPER * Δ
23	31606	1	CUP SEAL* Δ
24	36111	1	CYLINDER
25	07572	1	O-RING * Δ
26	33520	1	PISTON
27	33521	1	TUBE
28	35546	1	DOWEL PIN, 5/32 × 1.500
29	31592	1	SHUTTLE VALVE
30	65835	1	CHUCK END
	66258	1	CHUCK END (CH1533101 U/W ONLY)
31	35976	4	CAPSCREW 1/4 × 1.500
32	03210	1	RETAINING NOSE LINER
33	33294	1	FOAM GRIP
34	38597	1	RETAINING RING – U/W MODEL ONLY
35	65836	1	SOLID RETAINER
36	65837	1	RETAINER SPRING
37	01412	2	PIGTAIL HOSE ASSY 12
38	03971	1	FLUSH FACE COUPLER SET
39	81112	1	VALVE ASSEMBLY (PURCHASE ASSEMBLY TO REPLACE ANY VALVE COMPONENTS ON MODELS PRIOR TO S/N 110917173)
SK1	35979	1	* SEAL KIT (MODELS PRIOR TO S/N 110917173)
SK2	81139	1	Δ SEAL KIT (MODELS AFTER S/N 110917173)

MODEL DESIGNATIONS	
CH1513101	8 GPM MODEL
CH1533101	8 GPM MODEL, UNDERWATER