



**Multifunction Pistol Safe (RP2002)  
Instruction Manual**

RPNBSafe delivers security exactly where you want it.



# Box Contents

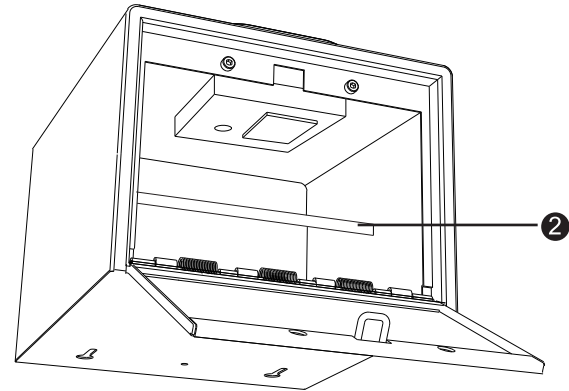
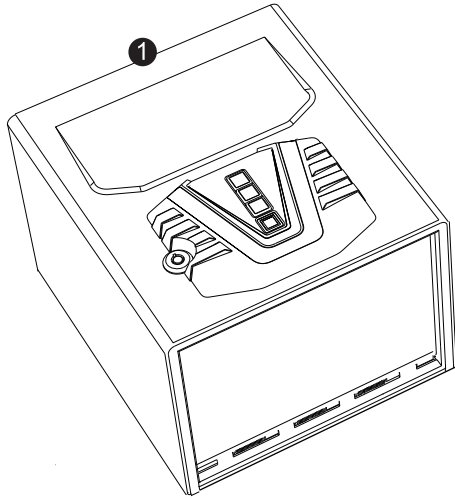

3



4

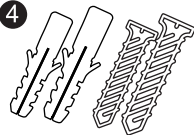

5



- 1 RPNB® Safe
- 2 Removable Shelf
- 3 Owner's Manual/ Quick Start Guide
- 4 Hardware Mounting Kits
- 5 Backup Keys (2)

## Warnings

To prevent damage to your RPNB® unit or injury to yourself or to others, read the following safety precautions before using this unit.

**DO NOT PLACE OR STORE THE BACKUP KEYS INSIDE THE SAFE AT ANY TIME. IF THE BATTERY FAILS, YOU WILL BE UNABLE TO OPEN THE SAFE.**

**DO NOT** expose to extreme heat or cold. Battery power may be affected.

**DO NOT** store loaded guns in this unit. Firearms are serious in nature and must be handled with respect. Store responsibly.

**ALWAYS** check to make sure door has latched when closing; Lid requires a firm press and locks automatically.

## Disclaimers

Neither seller nor manufacturer shall be liable for unauthorized access, any injury, loss or damage to personal property direct or consequential, arising out of the use of, or the inability to use the RPNB® Safe.

The user shall determine the suitability of the RPNB® Safe before the intended use and user assumes all risk and liability whatsoever in connection therewith, RPNB® Safe are not intended to protect against environmental hazards including fire and water.

Be sure and follow all local and state firearm laws.

**DO NOT** operate a firearm without proper training and experience.

## Battery Installation

- 1 To get started, insert one of your backup keys into the keyhole at the front of the safe. Push key in and rotate the key 30 degrees anticlockwise (LEFT) to open the safe (see Figure A).
- 2 Locate the battery compartment door on the inside of the safe directly below the keypad (see Figure B).
- 3 Open the battery cover and insert the 4 AA alkaline batteries (not included) into the battery compartment. Note that pay attention to the "+" and "-" signs. The "-" end of the batteries go against the spring inside of the compartment.
- 4 When the batteries are inserted correctly you will hear a short beep.
- 5 Once you hear the beep, place the battery cover. You are now ready to program your safe.

### IMPORTANT :

- Use the NEW AA alkaline battery. Using other batteries may cause unusable conditions.
- Your RPNB® safe will automatically lock when you fully close the lid.

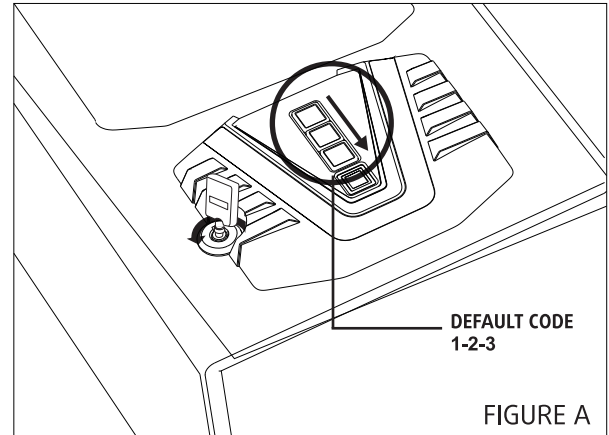

FIGURE A

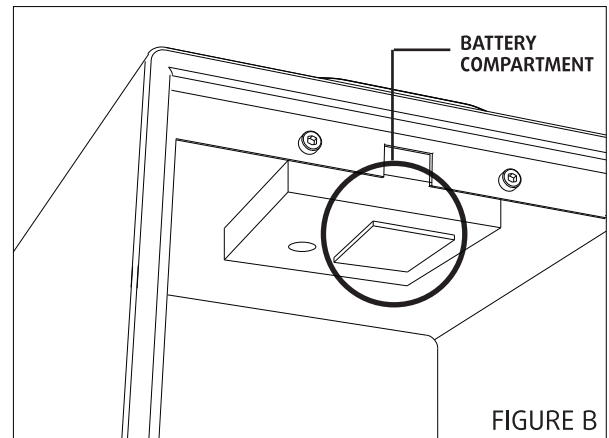

FIGURE B

# Master Code Programming

**First time users should change the default code as soon as possible** to prevent unauthorized access to your safe, so it should be kept confidential.

## TIP: Code Requirements

- Your code can be a minimum of 3 and a maximum of 6 digits. For your security, the safe will time out and sleep for five minutes if 5 incorrect entries are made. The safe can still be opened by using the backup keys override.
- Two keys cannot be pressed simultaneously.
- Programming a new code will overwrite your previous code.

- 1 Enter default code 1-2-3 on the keypad to open your safe (see Figure A).
- 2 With the safe open, press and hold the "PROGRAM" button (3 seconds), the keypad will light up WHITE once with one beep(see Figure C).
- 3 Enter your NEW master code.
- 4 Press the "PROGRAM" button once and release it, the keypad will light up WHITE twice with the double beeps. This tone confirms that the password has been reset.
- 5 Now test the code. If you make a mistake, the keypad will RED 5 with 5 beeps, and the new code will not work, simply start over with step 2.

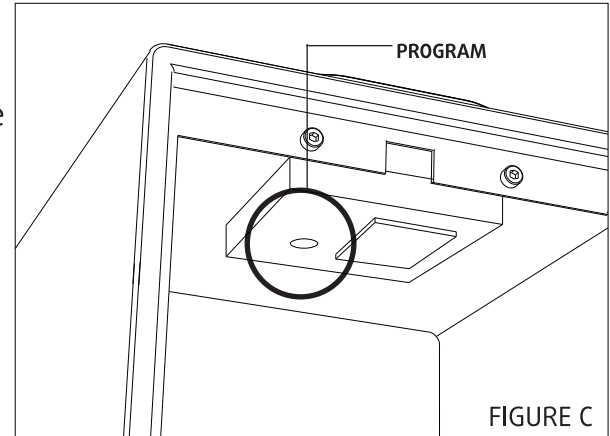

# Registering Fingerprints

## Helpful Programming TIPS :

- 1 Place your finger on the center of the scanner (this allows the scanner to read where most of the fingerprint detail is located).
- 2 Adjust your finger slightly between scans for increased accuracy.
- 3 Excessive moisture, lotions, or dirt will affect your fingerprint and may cause inaccurate sensor reading.
- 4 If you are experiencing difficulty try different fingers. Each finger is unique, and some fingers such as your thumb, contain more readable information than others.
- 5 To increase your success rate, please register the same fingerprint multiple times.

FIGURE D

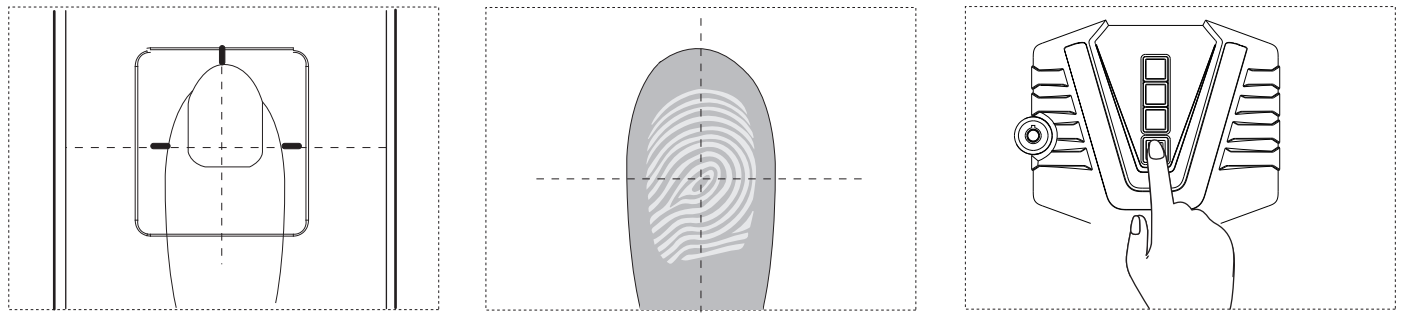

## Programming the Fingerprints

### To Register Your Fingerprint, Locate the "Program" Button.

- 1 With the safe open, press and hold the "PROGRAM" button (3 seconds) (see Figure E), the keypad will light up WHITE once with one beep.
- 2 Using the helpful programming tips provided on page 5 (see Figure D) place your finger on the fingerprint scanner for the 1st of four scans. When the safe a short beep once and the keypad light up WHITE remove your finger. Place finger again over the scanner until the safe a short beep once and the keypad light up WHITE and lift. You will repeat this process until the keypad light up twice with the double beeps.
- 3 Now your fingerprint has been successfully registered. Close door and test to see if the safe will open using your fingerprint. If you make a mistake and the new fingerprint will not work, you must repeat the above steps.

### Note:

- If all keys flash RED 5 times with 5 beeps, it means registration has failed and you must repeat the above steps.
- You cannot register more than 20 fingerprints. If the light flashes RED 5 times with 10 beeps when you register once your fingerprint, it means the fingerprint storage capacity is full.

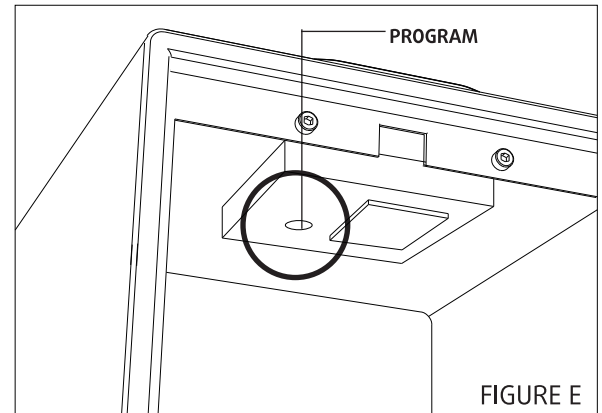

FIGURE E



## Delete the Registered Fingerprint

- 1 Press and hold the program button.
- 2 You will see the light flash WHITE once and hear one beeps.
- 3 Keep holding the program button until you hear another double beeps with two WHITE flashes, then release it. (The whole process will take 5-6 seconds.)
- 4 Now all registered fingerprints are erased.

### IMPORTANT

When only flash once with one beep, do not let go. You must hold the program button until the light flash twice with double beeps, then release it.

## Silence Mode Setting

To silence the audible sound of the electronics, hold the “1” button for 3 seconds until you hear one beep and the light will flash once together. To unmute the keys, repeat this step.

## Low Battery Warning

If the keypad light up WHITE once and then light up RED 10 times with 10 beeps when opening the safe by electronic way, your battery level is critically low and your safe needs to be replaced the 4 new batteries.

## Securing Your Safe

There are some mounting screws included to mount your RPNB® safe to a flat surface using the pre-drilled holes on the bottom.

### Using the Mounting Screws

**TIP:** Make sure you have enough clearance for the lid to open properly before mounting the safe.

- 1 Position the safe on a flat surface where you want to mount it.
- 2 Use a pencil to mark the holes for drilling.
- 3 Drill pilot holes.
- 4 Position safe in place and install screws through safe into pilot holes. Tighten screws.

### IMPORTANT

Mounting the safe vertically so that the door flips upward will result in incomplete opening of the safe due to weight. The door will open if the safe is mounted vertically so that door opens down or to side.

## Customer Support/Warranty

### Customer Support

If you have a problem with your RPNB® safe that is not answered in the this manual, we encourage you to email us: [CUSTOMERSUPPORT@RPNBSAFE.COM](mailto:CUSTOMERSUPPORT@RPNBSAFE.COM)

## How shall I view tutorial videos?



- 1 Go to our website via: **www.rpnbsafe.com**
- 2 Select the "**Customer Service**" on the navigation bar
- 3 Click "**How To Video**"
- 4 Select the product model you purchased

### How shall I replace keys?

- 1 Go to our website via: **www.rpnbsafe.com**
- 2 Select the "**Customer Service**" on the navigation bar
- 3 Click "**Replace Keys**"
- 4 Fill in the required information

### How shall I order accessories?

- 1 Go to our website via: **www.rpnbsafe.com**
- 2 Select the "**Customer Service**" on the navigation bar
- 3 Click "**Order Accessories**"
- 4 Fill in the required information

 More online at [www.rpnbsafe.com](http://www.rpnbsafe.com) under support

## Linked Warranty (Terms and Conditions)

RPNB® is committed to building high quality products and will make every effort to ensure our products are free from any defects. We guarantee your safe will be free of defects in materials or workmanship for a period of one year from the date of original. This warranty does not cover abuse, misuse, use in any manner for which is not designed, neglect, modification, damage in advertently caused by the owner; accidents, and/or tampering.

If you safe is determined to be defective and we are responsible for the cause we will have it repaired at our expense, or we will send a new replacement at no cost to you. You will be required to return your existing unit as well as all included accessories to RPNB® prior to replacement of the defective unit along with your order of purchase.

If it is determined your safe needs to be returned our customer support team will provide you with a return detail.

Please have the following information available when contacting us:



- Purchaser's name and mailing address, email address, and phone number
- Online order number
- Detailed description of problem

NEITHER SELLER NOR MANUFACTURER SHALL BE LIABLE FOR ANY INJURY, LOSS OR DAMAGE, DIRECT OR CONSEQUENTIAL, ARISING OUT OF THE USE OF, OR THE INABILITY TO USE THE RPNB® SAFE.

## How shall i talk to them?

Go to Your Orders, find your order in list, and click get product support.

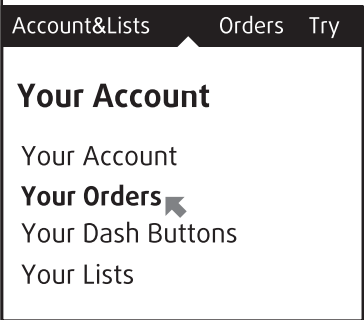
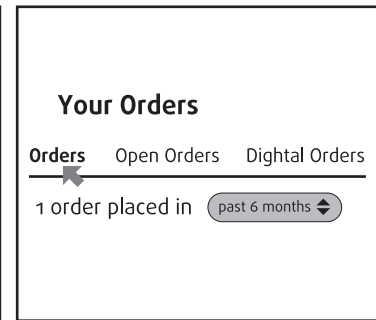
You can e-mail the seller by doing the following:

 <p>Account&amp;Lists Orders Try</p> <p><b>Your Account</b></p> <p>Your Account</p> <p><b>Your Orders</b> ←</p> <p>Your Dash Buttons</p> <p>Your Lists</p>	 <p><b>Your Orders</b></p> <p>Orders Open Orders Digital Orders</p> <p>1 order placed in <span>past 6 months</span> ▾</p>	 <p><b>Get product support</b> →</p> <p>Write a product review</p> <p>Archive order</p>	 <p><b>Talk to an expert</b></p> <p>Figure out and fix what' s wrong,get</p> <p>phone chat →</p> <p>if a new window doesn' t appear,chan</p>
<p>1.Go to your account find the order</p>	<p>2.Find your order item</p>	<p>3.Click get product support</p>	<p>4.Give the seller 24hours to respond</p>

 Please email us to get a special **VIP** discount code before your next order.

 Problem with the order? Please email us, give us a chance to help you firstly.

 **Satisfied with us.**

Hum, this people is nice, i can give them a positive reviews to tell people they are selling good products, doing the right thing.



**RPTB**®

Dear Customer:  
Thank for your business  
— BEST WISHES FOR YOU —





**Customer Support Hours:**

Monday - Friday 9:00AM - 6:00PM (PST) Saturday - Sunday 9:00AM - 12:00PM (PST) Excluding Holidays

Hours subject to change

Customer Service Department Contact: [customersupport@rpnbsafe.com](mailto:customersupport@rpnbsafe.com)