





## Dual Carbon/StarWhite

I

Evoluzione dell'ombrellone singolo Astro. Armonico per tutti gli ambienti. Telaio con verniciatura antracite o bianco opaco, unico nel suo genere. Struttura in alluminio composta da 2 ombrelloni ancorati ad un unico sostegno. Soluzione studiata per ampie superfici. Apertura e chiusura retrattile al di sopra di tavoli e sedie senza dover spostare gli arredi.

EN

Evolution of the single parasol Astro. Harmonic for all environments. Epoxy coating anthracite grey or matt white. Aluminum structure composed of 2 parasols anchored to a single support. Solution designed for large surfaces. Retractable opening and closing above tables and chairs without moving the furniture.

D

Entwicklung des Models Astro mit einem Arm. Harmonisch für alle Milieus. Gestell mit Graphiteffekt. Aluminiumgestell mit 2 Sonnenschirmen, die an einem Mast befestigt sind. Für große Flächen geeignet. Einziehbares Öffnen und Schließen oberhalb von Tischen und Stühlen.

F

Evolution du parasol simple Astro. Harmonic pour tous les environnements. Vernis couleur gris anthracite ou blanc opaque, unique en son genre. Structure en aluminium composée de 2 parasols ancrés à un seul support. Solution conçue pour les grandes surfaces. Ouverture et fermeture au-dessus des tables et des chaises sans déplacer les meubles.

E

Evolución del parasol único astro. Armónica para todos los ambientes. Pintura antracita u opaca blanca , único en su clase. Estructura de aluminio compuesta por 2 parasoles anclados a un solo soporte. Solución diseñada para grandes superficies. Apertura y cierre retráctil sobre mesas y sillas sin mover los muebles.

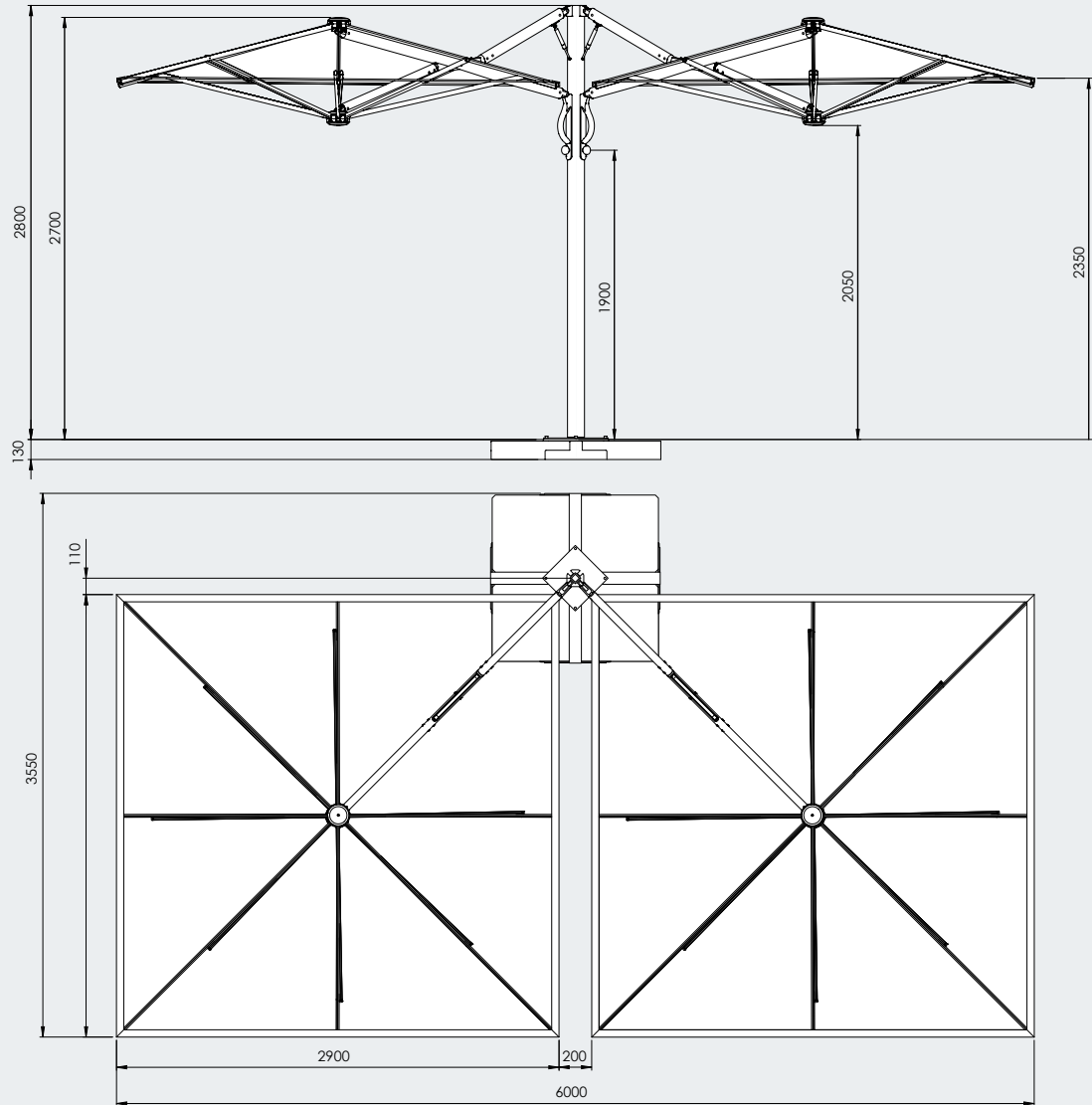
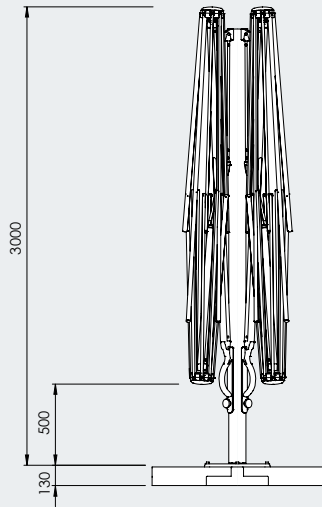

# 3,0x6,0

## Dual-V Carbon / StarWhite









CHARACTERISTICS										FINISHING						OPTIONAL			
↕	COD	KG	M <sup>3</sup>	🏠	🌳	☀️	📦	👤	360°	⚙️	🔧	📐	INOX	🌳	📐	BTB			
3,0x6,0	STARWHITE C3060 DVW	69	0,60	110x76	STAR WHITE	8	STAR WHITE	18x30	●	●	●	●	●	●	●	●	N°4 BC5151 N°12 BC5050	N°4 BV5050	FISSAGGIO TERRA INGROUND FIX
	CARBON C3060 DVC				CARBON		CARBON		●	●	●	●	●	●	●				

# Fabric collection

**350 gr/m<sup>2</sup>**

ACRYLIC



				
	<b>A1</b> ECRU NATURAL COL. NATUR	70/80%	20/30%	85/89%
	<b>T2</b> TERRACOTTA ZIEGELROT TERRACOTTA	> 90%	< 10%	100%
	<b>T3</b> BORDEAUX	> 90%	< 10%	100%
	<b>T6</b> GRIGIO TAUPE GREY TAUPE GRAU TAUPE GRIS TAUPE GRIJS TAUPE	> 90%	< 10%	100%
	<b>T7</b> BIANCO WHITE BLANC WEISS	70/80%	20/30%	85/89%
	<b>S1</b> NERO / BLACK SCHWARZ NOIRE NEGRO ZWART	> 90%	< 10%	100%

I dati forniti, pur essendo frutto di misurazioni scientifiche condotte in laboratori certificati, sono da ritenersi indicativi.

The above mentioned data are indicative, although provided by scientific measurements performed in certified laboratories.

# Bases



BC 5151G



BV5050G

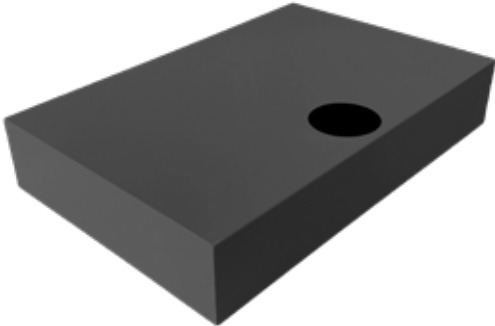

CARTER CARBON  
Cod. BCC  
ASTRO CARBON



BV5151



BV5050B



CARTER WHITE  
Cod. BCW  
ASTRO SPACEGRAY  
ASTRO STARWHITE

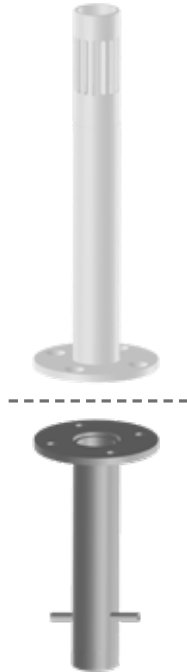

BTA INGROUND FIX  
ASTRO



BC5050

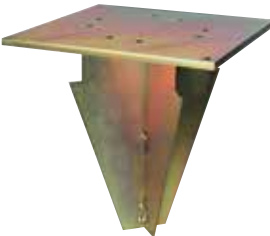

BTB INGROUND FIX  
DUAL - QUATTRO

mm	COD	mm	kg
500X500	<b>BC 5050</b>	40	20
500X500	<b>BC 5151</b>	110	60
500X500	<b>BC 5151G</b>	110	60
500x500	<b>BV5050G</b>	270	80
500x500	<b>BV5050B</b>	270	80
300x300	<b>BTB</b>	330	10
Ø 160	<b>BTA</b>	350	5

# Materiali e finiture Materials and finishes

## Componenti e profili alluminio Aluminium components and profiles



STARWHITE



SPACEGRAY



CARBON

## Profili stecche Rib profiles



STARWHITE



SPACEGRAY



CARBON



COVER BAG ASTRO

 .Dimensione (metri)  
.Dimensions (meters)  
.Masse (Meter)  
.Dimensions (metrès)  
.Dimensiones ( en metros)

 .Fodero  
.Cover bag  
.Schutzhuelle  
.Housse  
.Forro

 .Base girevole a 360°C  
.Revolving base 360°C  
.360°C drehbarer Staender  
.Base tournant 360°C  
.Base giratoria 360°

 .Codice  
.Code  
.Artikelcode  
.Code  
.Código

 .Sistema retrattile  
.Retractable system  
.Einziehbares System  
.Système retractile  
.Sistema retráctil

 .Sezione sostegno (mm)  
.Support section (mm)  
.Mastprofil (mm)  
.Section support (mm)  
.Sección soporte (mm)

 .Lunghezza  
.Length  
.Laenge  
.Longueur  
.Longitud

 .Apertura con molla a gas  
.Gas spring opening  
.Gasfeder oeffnung  
.Ouverture avec ressort à gaz  
.Abertura muelle a gas

 .Viteria in inox e ottone nichelato  
.Screws in Stainless steel and nickel plated brass  
.Edelstahlschrauben und vernickeltes Messing  
.Visserie inox et laiton nickelé  
.Tornillos en acero inoxidable y bronce niquelado

 .Peso  
.Weight  
.Gewicht  
.Poids  
.Peso

 .Con base/supporto  
.With base/support  
.Mit Staender/Huelse  
.Avec base/support  
.Con base/ soporte

 .Tipo finitura della struttura/sostegno/componenti  
.Finishing for frame/structure/components  
.Ausfuehrung des Gestells/der Struktur/der Bestandteile  
.Finition armature/structure/composants  
.Tipo de acabado de la estructura/Soportes/componente

 .Volume (m3)  
.Volume (m3)  
.Volumen (m3)  
.Volume (m3)  
.Volumen (m3)

 .Sezione stecche  
.Rib section  
.Strebenprofil  
.Section baleines  
.Sección varillas

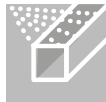
 .Colore dei componenti/stecche  
.Component/Ribs colour  
.Farbe der Bestandteile und Streben  
.Couleur des composants et baleines  
.Color de los componentes ò piezas/Varillas ò listones

 .Stecche  
.Ribs  
.Streben  
.Baleines  
.Varillas

 .Camino antivento  
.Wind cap  
.Windfang  
.Souffle  
.Chimenea antiviento

 .Stecca con sistema "easy change"  
.Ribs with "easy change" system  
.Streben mit "easy change" System  
.Baleines avec "easy change" système  
.Varillas con sistema de " cambio fácil"

 .Massima Stabilità Ottenibile  
.Maximum Obtainable Stability  
.Maximal Erhaeltliche Stabilitaet  
.Maximum De Stabilité Realisable  
.Maxima Estabilidad Posible

 .Peso consigliato in condizioni normali  
.Recommended weight in normal condition  
.Empfohlenes gewicht unter normalen bedingungen  
.Poids recommande dans des conditions normales  
.Peso recomendado en condiciones normales

 .Peso minimo richiesto  
.Minimum ballast required  
.Erforderliches mindestgewicht  
.Poids minimum requis  
.Peso minimo requerido