

# 1Touch

by UNIPRO TOOLS

## Quick Start Assembly Guide

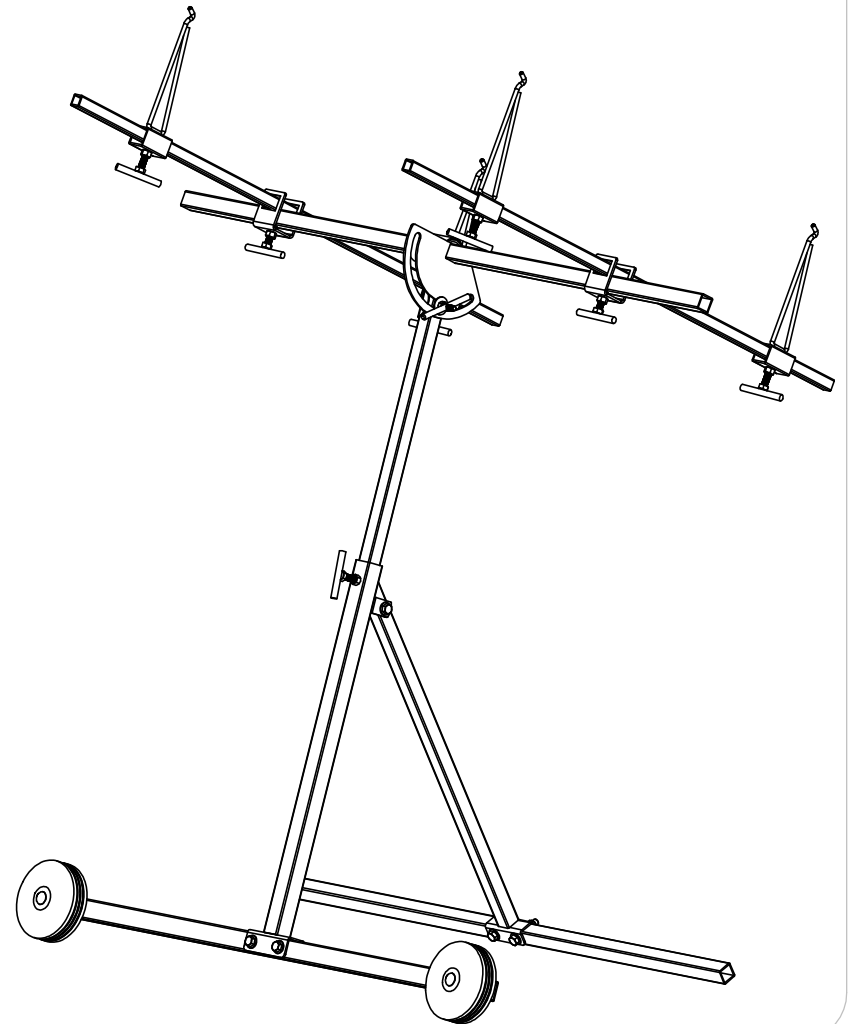

QUESTIONS OR COMMENTS?  
**1.800.560.9060**  
[www.1TouchUniPro.com](http://www.1TouchUniPro.com)

1.

Fastern Bottom Tube to the Vertical Support Tube.

- 2) Bolts
- 4) Washers
- 2) Nuts

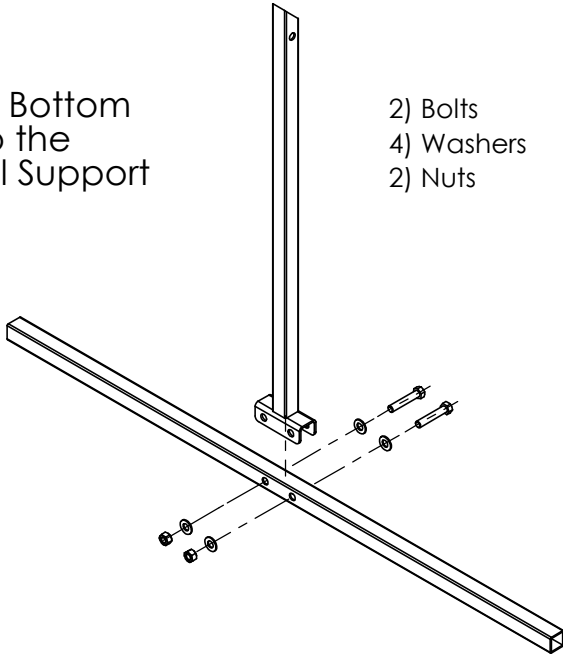

2.

Fastern Wheels and Main Vertical Rod to Main Bottom Tube.

- 2) Long Bolts
- 2) Short Bolts
- 2) Sleeves
- 6) Washers
- 4) Nuts

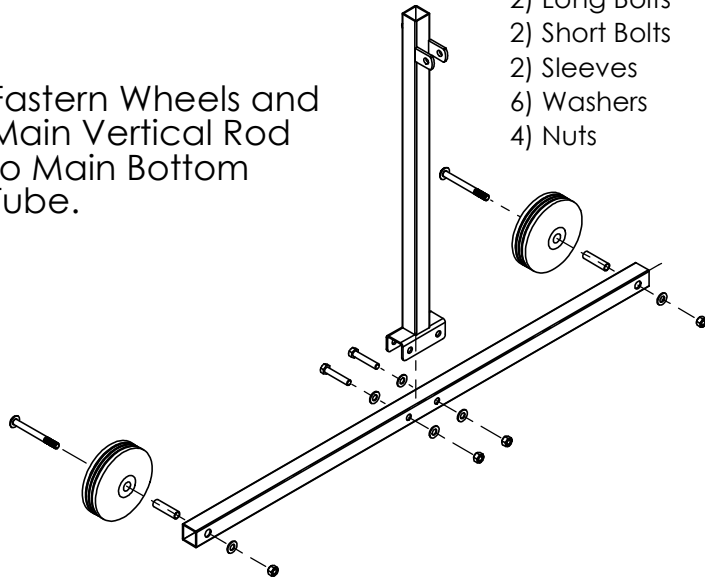

#	DESCRIPTION	QTY.
1	Vertical Tube	1
2	Cradle Bracket	1
3	Rotation Lock Tube	1
4	Top Bar	2
5	Main Bottom Tube	1
6	Main Vertical Tube	1
7	Bottom Tube	1
8	Vertical Support Tube	1
9	Large T-Handle	1
10	T-Handle	7
11	Wheel	2
12	Arm Bracket	2
13	Hook	4

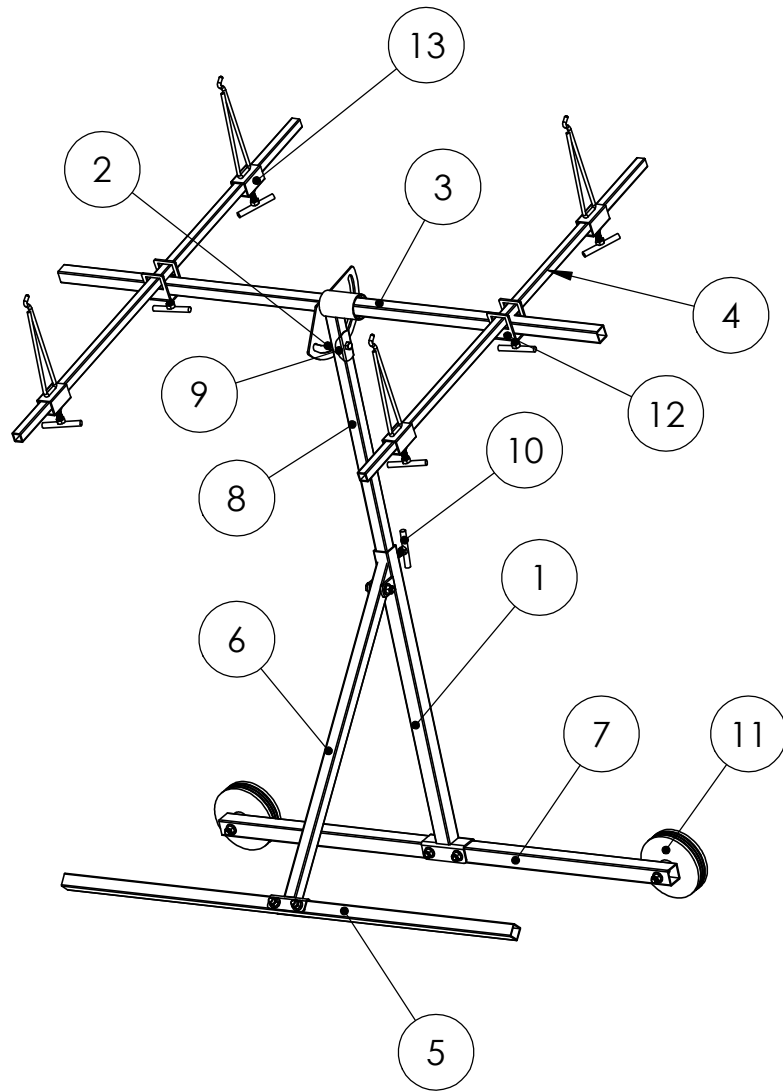

**3.**

Mount Support  
Leg to Main  
Tube.

- 1) Long Bolt
- 2) Washers
- 1) Nut

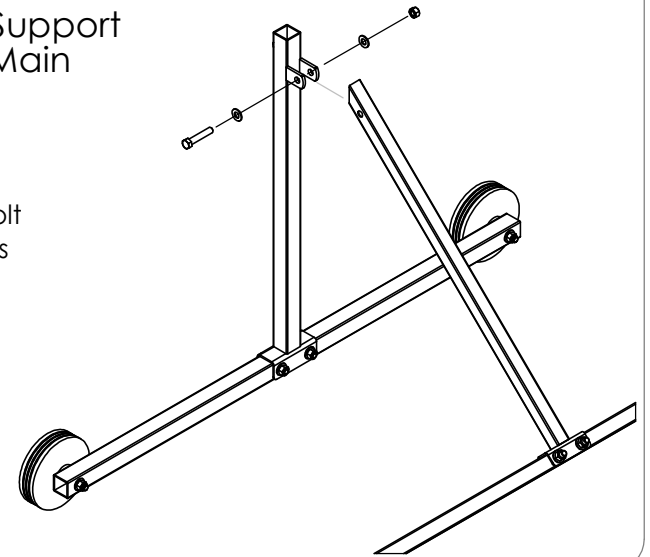

**4.**

Insert Inner Support  
Rod and secure with  
T-Handle.

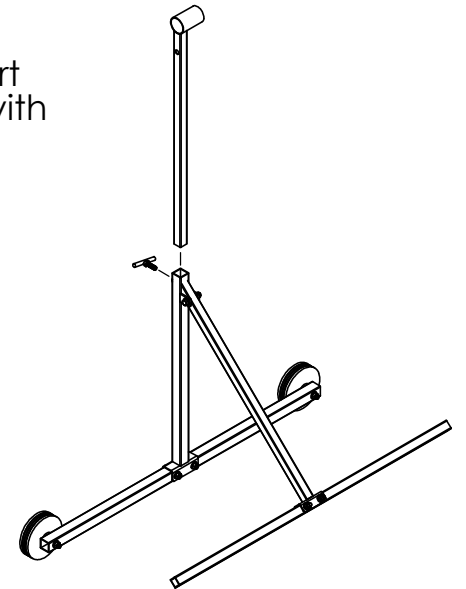

5.

Insert Rotation Lock Bar into Barrel.

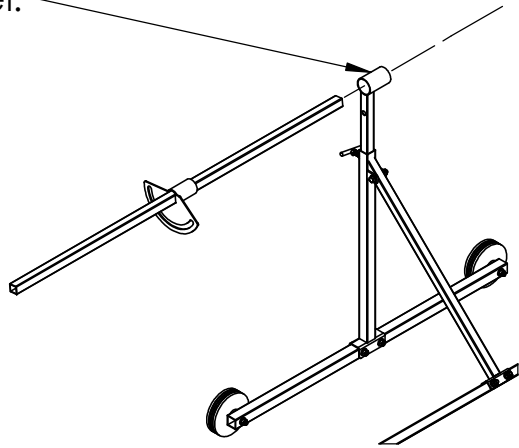

7.

Slide Arm Bracket and Hooks onto Top Bars and secure with T-Handles.

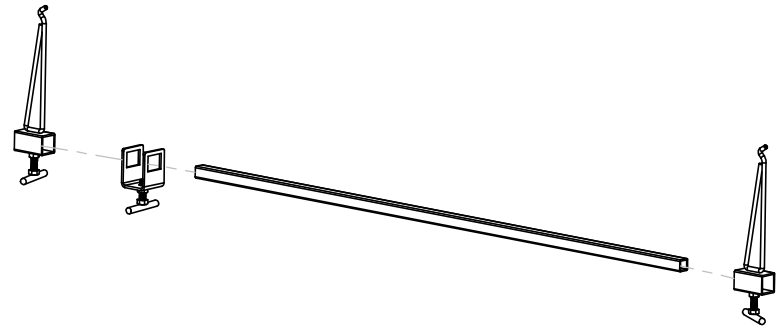

6.

Fasten Rotation Lock with Large T-Handle and Cradle Bracket.

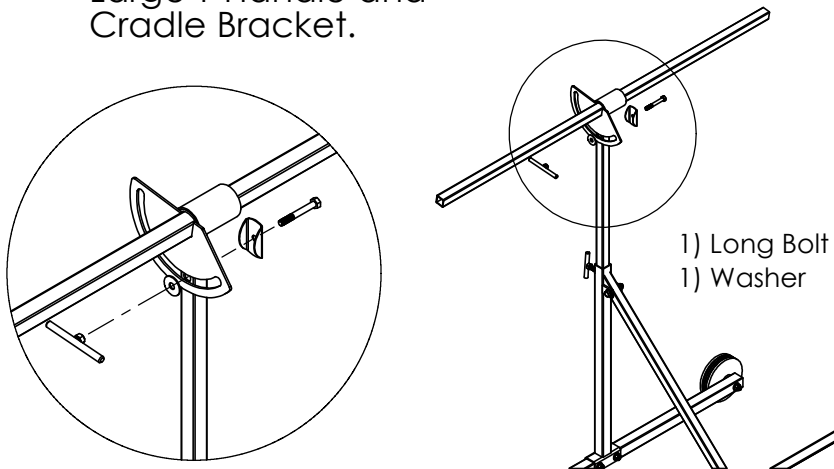

8.

Slide Top Bar components onto Rotation Lock Bar and secure with T-handles.

