

**CURVED GLASS CANOPY**

**900mm**

**RGT9**



Baffle filters

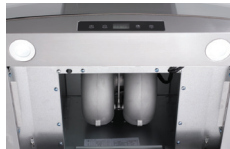

New generation Air Tech Motor – more power and quieter

- Stainless steel and black glass
- 950m<sup>3</sup>/hr
- Ducted operation
- Re-circulating operation optional\*
- Touch control - backlit display
- Timer operation
- 3 speed fan
- 2 x Baffle filters for easy cleaning - dishwasher safe
- 2 x 3 watt LED lamps cooler and longer lasting

**features**

specifications

<b>Airflow:</b>	950m <sup>3</sup> /hr	<b>*Re-circulating Kit:</b>	IA150BRK
<b>Noise level:</b>	51 -65 dBA on maximum setting	<b>Extension Flue:</b>	IAGXSE1 (900mm)
<b>Lighting:</b>	2 x 3 watt LED lamps	<b>Carbon Filter:</b>	CF260
<b>Total wattage</b>	270 Watts		
<b>Power:</b>	220 -240 volt / 50Hz (fitted with 10amp, 3 pin plug)		
<b>Power Cord:</b>	1.5 metre cable		
<b>Ducting Spigot size:</b>	150mm		

dimensions

**Product Dimensions** 900mm (W) x 605 - 1085mm (H) x 500mm (D)

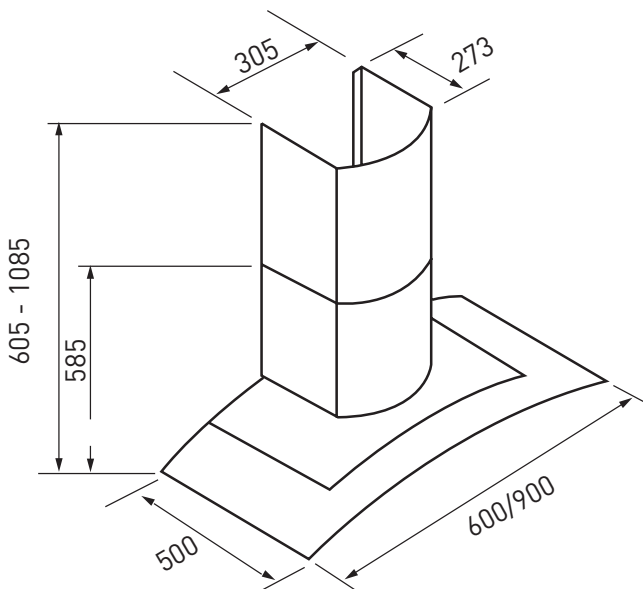

warranty - customer service

**Warranty**

2 years Parts and Labour

**Customer Service**

Our Nationwide Service Team can be contacted on our Toll Free Customer Service Number 1800 805 300 or by logging on to <http://customersupport.hapl.com.au/>



20 Carlotta Street  
 Artarmon NSW 2064  
 T: 02 9958 3111  
 F: 02 9958 3555  
 E: info@hapl.com.au

[www.hapl.com.au](http://www.hapl.com.au)