

INLC90

Off Board Canopy Rangehood 900mm

Euromaid

made for you.

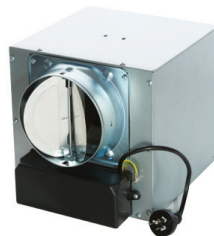

Separate fan motor

Features

- Stainless Steel flat canopy rangehood
- Separate fan motor - ceiling cavity installation
- 1000 m³/hr air extraction
- 3 speed push button controls
- 2 x energy efficient LED lights
- 3 x baffle filters
- 3 metre flexi-duct - included

Specifications

- | | |
|----------------------|------------------------|
| Airflow: | 1000m ³ /hr |
| Lighting: | 2 x LED lights |
| Total Wattage: | 269watts |
| Ducting Spigot Size: | 150mm |

Total Power

- | | |
|-------------|---|
| Power: | 220 -240 volt / 50Hz
(fitted with 10amp, 3 pin plug) |
| Power Cord: | 4+metre cable |

INLC90

Dimensions & Installation

Euromaid
made for you.

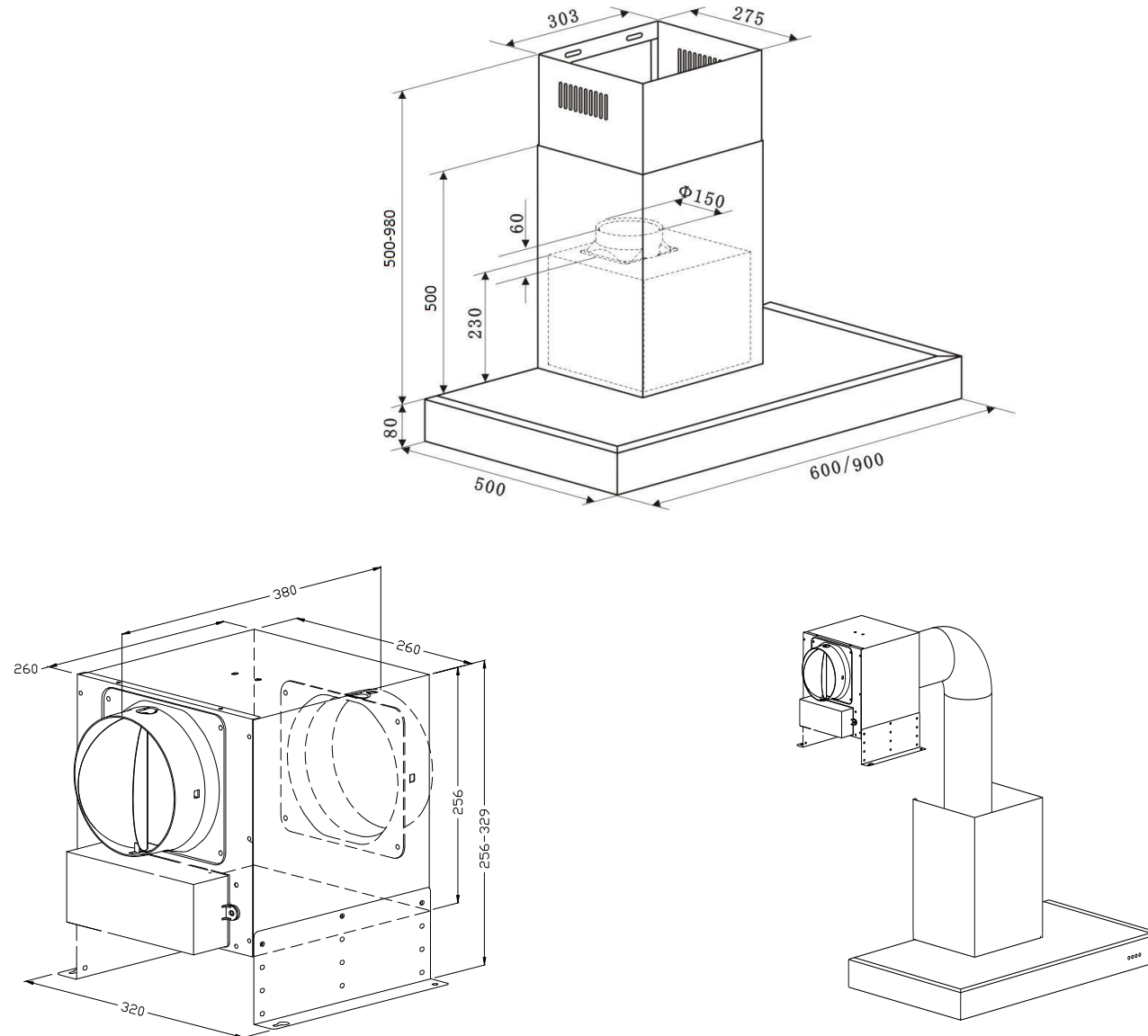

Product Dimensions

900mm (W) x 500mm (D) x 500-900(H)

The location of the fan unit shall allow access for maintenance and repair.

Permanent fixed means of access is required where the fan unit location is beyond the extent of normal steps or ladders.

The fan motor must be firmly affixed to the ceiling rafters.



Warranty
2 year Parts and Labour