

MODEL CAFG91B

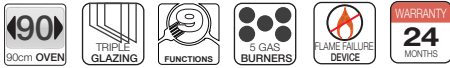

90CM GAS/ELECTRIC FREESTANDING COOKER



PRODUCT INFORMATION

- oven capacity: 104 litres
- gloss black

OVEN

- 9 functions — top and bottom element, defrost, fan assisted, fan forced, fan grill, grill, rotisserie, base heat, light
- double cavity cooking fan
- 50–250°C thermostat
- digital clock
- triple-glazed glass door
- electric grill + rotisserie
- oven light
- removable oven cavity floor
- 4 cooking levels
- baking tray + 2 wire oven racks
- adjustable legs
- warming compartment

COOKTOP

- 1 triple ring 3.6 kW/hr
- 1 rapid burner 3.0 kW/hr
- 2 semi-rapid 1.75 kW/hr
- 1 auxiliary 1.0 kW/hr
- cast-iron trivets and burner caps
- flame failure device fitted to each burner
- automatic ignition
- single-piece 5 gas burner pressed hob



BRUSHED MATT BLACK
HANDLE

EAN 9347777001283

AR200818

DISCLAIMER

Eurolinx PTY LTD, is continually seeking ways to improve the design specifications, aesthetics and production techniques of its products. As a result alterations to our products and designs take place continually. Whilst every effort is made to produce information and literature that is up to date, this brochure should not be regarded as an infallible guide to the current specifications, nor does it constitute an offer for the sale of any particular product. Product dimensions indicated in our literature is indicative only. Actual product only should be used to define dimension cut outs. Distributors, and retailers are not agents of Eurolinx and are not authorized to bind Eurolinx by any express or implied undertaking or representation.

FOLLOW US ON: [instagram.com/artusi_appliances](https://www.instagram.com/artusi_appliances)

www.linkedin.com/company/eurolinx-pty-ltd-t-a-llve/

Australia National Telephone Number 1300 (694 583) New Zealand Telephone Number 64 3 344 5913
Artusi showroom hours: Tuesday to Friday - 9am-5pm, Saturday - 10am-4pm, Sunday and Monday - closed
* Melbourne showroom hours: Tuesday to Saturday - 10am-4pm

[artusi.com.au](https://www.artusi.com.au)

NSW & ACT (Head Office)
48-50 Moore Street
Leichhardt
F 02 8569 4699

VIC & SA
1211 Toorak Road
Camberwell
F 03 9809 2155

QLD
1/42 Cavendish Road
Coorparoo
F 07 3397 0850

WA & NT
Unit 10/55 Howe Street
Osborne Park
F 08 9201 9188

TAS
3 Pear Avenue
Derwent Park
F 03 6272 7386

New Zealand
PO Box 11.160
Sockburn Christchurch
F 03 344 5906

MODEL CAFG91B



90CM GAS/ELECTRIC FREESTANDING COOKER



TECHNICAL DIAGRAM

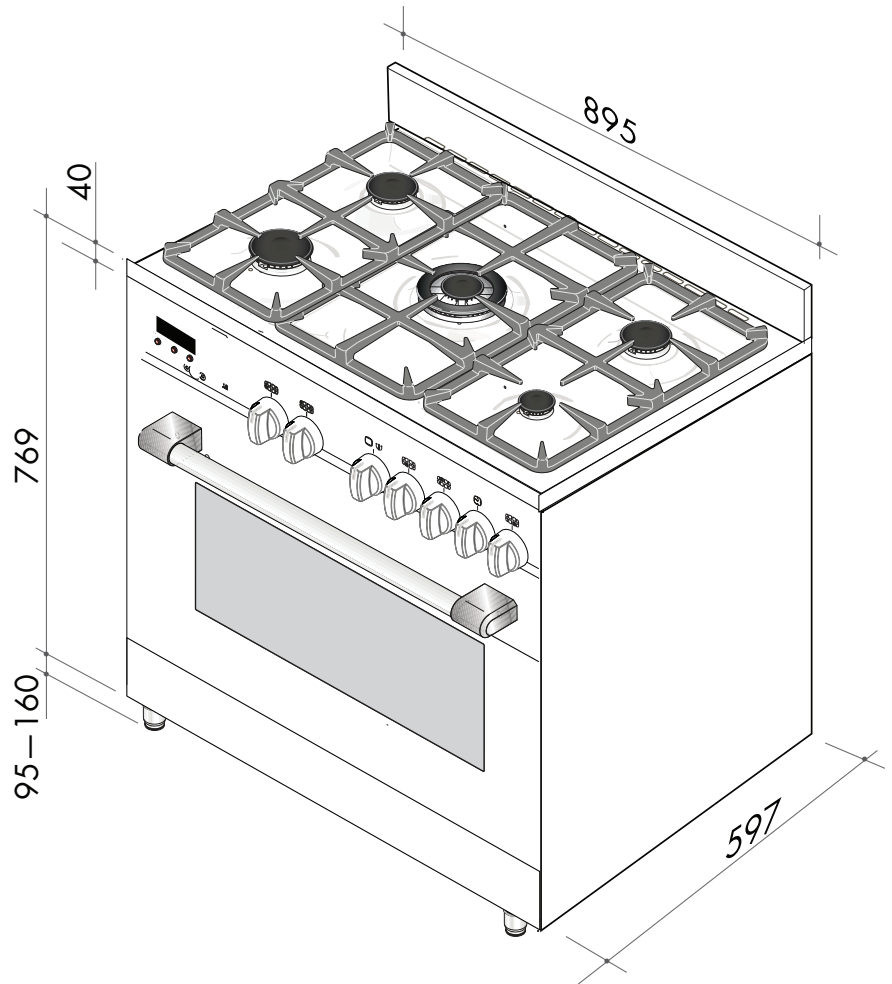

NB: drawings are not to scale — they are to be used for detailed installation instructions, please refer to user guide.

EAN 9347777001283

AR200818

DISCLAIMER

Eurolinx PTY LTD, is continually seeking ways to improve the design specifications, aesthetics and production techniques of its products. As a result alterations to our products and designs take place continually. Whilst every effort is made to produce information and literature that is up to date, this brochure should not be regarded as an infallible guide to the current specifications, nor does it constitute an offer for the sale of any particular product. Product dimensions indicated in our literature is indicative only. Actual product only should be used to define dimension cut outs. Distributors, and retailers are not agents of Eurolinx and are not authorized to bind Eurolinx by any express or implied undertaking or representation.

CAGH91B Freestanding Cooker

Power Consumption: 2.94 kW/h

Gas Consumption: 11.1 mj/h (natural gas)

Electrical Connection: Hard Wired, 15 AMP
plug and lead not supplied

FOLLOW US ON:  [instagram.com/artusi_appliances](https://www.instagram.com/artusi_appliances)

 www.linkedin.com/company/eurolinx-pty-ltd-t-a-lve/

Australia National Telephone Number 1300 (694 583) New Zealand Telephone Number 64 3 344 5913
Artusi showroom hours: Tuesday to Friday - 9am-5pm, Saturday - 10am-4pm, Sunday and Monday - closed
* Melbourne showroom hours: Tuesday to Saturday - 10am-4pm

[artusi.com.au](https://www.artusi.com.au)

NSW & ACT (Head Office)
48-50 Moore Street
Leichhardt
F 02 8569 4699

VIC & SA
1211 Toorak Road
Camberwell
F 03 9809 2155

QLD
1/42 Cavendish Road
Coorparoo
F 07 3397 0850

WA & NT
Unit 10/55 Howe Street
Osborne Park
F 08 9201 9188

TAS
3 Pear Avenue
Derwent Park
F 03 6272 7386

New Zealand
PO Box 11,160
Sockburn Christchurch
F 03 344 5906