

AO888X

60cm built-in double electric oven

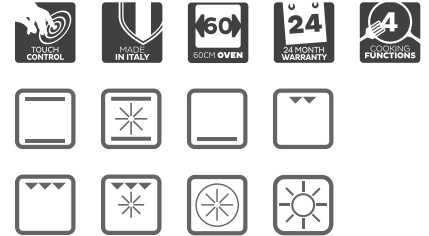

| | |
|------------------|---|
| SIZE mm | 594W x 888H x 540D + 21mm fascia |
| FINISH | AS304 stainless steel |
| CAPACITY | 36 litres (top oven) (32 lt usable) 65 litres (main oven) (58 lt usable) |
| FUNCTIONS | 4 + 4 functions |
| FEATURES | <ul style="list-style-type: none"> • digital timer with touch controls • EVER-Clean enamel interior • thermostat 0-250°C • knob control • flat, easy-clean inner glass door • tangential fan ventilation • 5 cooking levels (main oven) • 2 cooking levels (top oven) |
| POWER | 4.25 kW/hr total electrical consumption 15 amp electrical connection, hard wired |



EAN 9347777000385

DISCLAIMER

Eurolinx PTY LTD is continually seeking ways to improve the design specifications, aesthetics and production techniques of its products. As a result alterations to our products and designs take place continually. Whilst every effort is made to produce information and literature that is up to date, this brochure should not be regarded as an infallible guide to the current specifications, nor does it constitute an offer for the sale of any particular product. Product dimensions indicated in our literature is indicative only. Actual product only should be used to define dimension cutouts. Distributors, and retailers are not agents of Eurolinx and are not authorized to bind Eurolinx by any express or implied undertaking or representation.

AR300316

AO888X

60cm built-in double electric oven

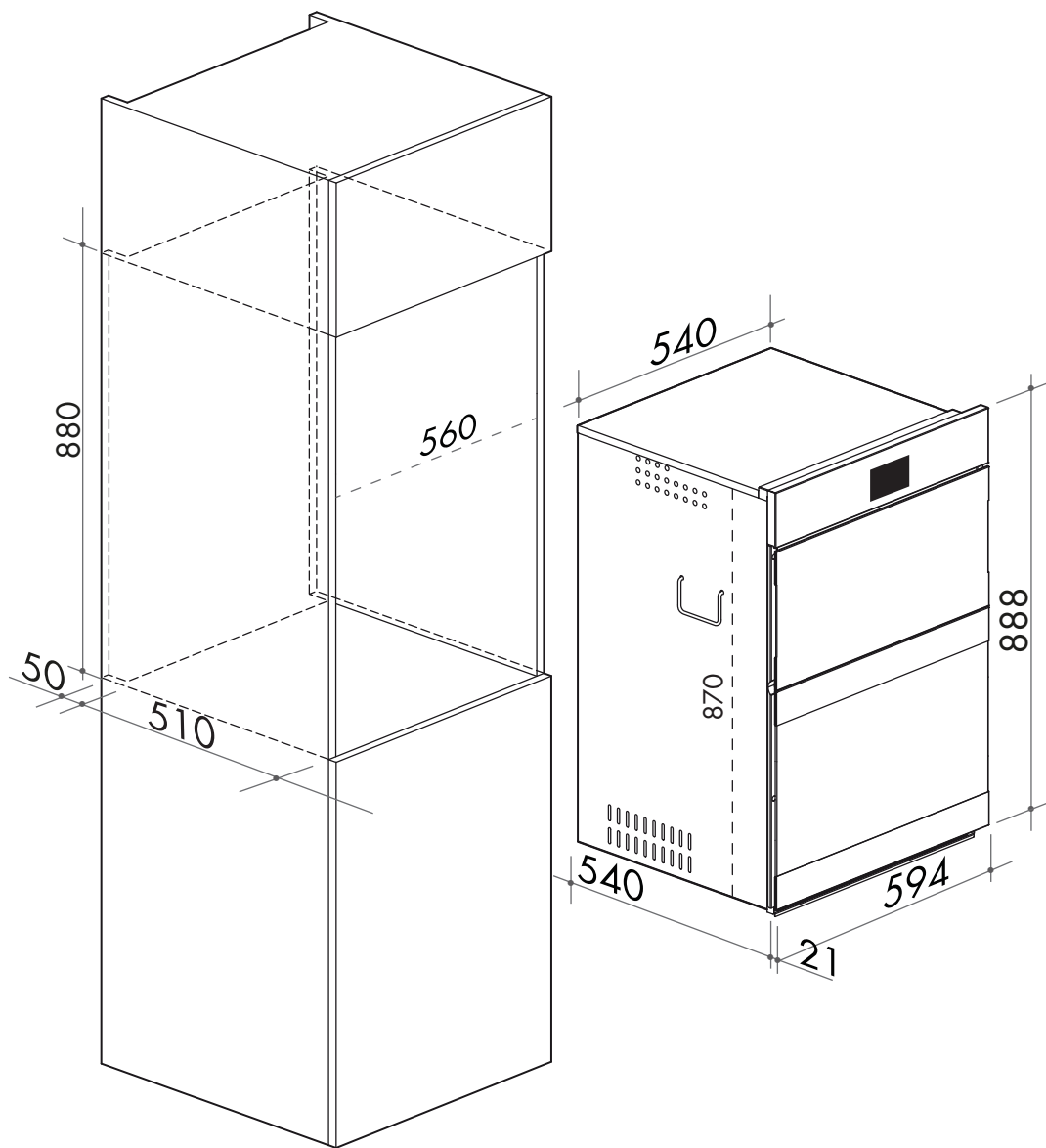

NB: drawings are not to scale — they are to be used as a guide only. For detailed installation instructions, please refer to user guide.

Australia National Telephone Number 1300 694 583 New Zealand Telephone Number 0508 458 369
 ARTUSI showrooms are open daily from 9am-5pm and Saturdays 10am-4pm

artusi.com.au

NSW & ACT
(head office)

48 Moore Street
 Leichhardt
 02 8569 4699

VIC | SA

1211 Toorak Road
 CAMBERWELL
 03 9809 2155

TASMANIA

3 Pear Avenue
 DERWENT PARK 7009
 03 6272 7386

QLD

1/42 Cavendish Road
 COORPAROO
 07 3397 0850

WA | NT

10/55 Howe Street
 OSBORNE PARK
 08 9201 9188

New Zealand

PO Box 11.160
 Sockburn Christchurch
 03 344 5906