

MODEL ACH600X



60CM CANOPY RANGE HOOD



PRODUCT INFORMATION

- stainless steel
- 2 x aluminium filters
- front push-button control
- 900m³/hr airflow
- 58 dBA
- 2 x 24W light bulbs
- 3 speeds
- Ø150mm ducting | recirculation kit available
- 10 AMP electrical connection, 3-pin plug and cord



EAN 9347777000682

AR10092018

DISCLAIMER

Eurolinx PTY LTD, is continually seeking ways to improve the design specifications, aesthetics and production techniques of its products. As a result alterations to our products and designs take place continually. Whilst every effort is made to produce information and literature that is up to date, this brochure should not be regarded as an infallible guide to the current specifications, nor does it constitute an offer for the sale of any particular product. Product dimensions indicated in our literature is indicative only. Actual product only should be used to define dimension cut outs. Distributors, and retailers are not agents of Eurolinx and are not authorized to bind Eurolinx by any express or implied undertaking or representation.

ARTUSI SHOWROOMS ARE OPEN TUESDAY TO FRIDAY FROM 9AM-5PM AND SATURDAYS 10AM-4PM (MELBOURNE TUE-SAT 9.30AM - 4PM)

NSW & ACT
(HEAD OFFICE)

48 MOORE STREET
LEICHHARDT

VIC | SA

1211 TOORAK ROAD
CAMBERWELL

TASMANIA

3 PEAR AVENUE
DERWENT PARK

QLD

1/42 CAVENDISH ROAD
COORPAROO

WA | NT

10/55 HOWE STREET
OSBORNE PARK

NEW ZEALAND

CHRISTCHURCH
P. 03 344 5913
ARTUSI.CONZ

P: 1300 649 583

ARTUSI.COM.AU

MODEL ACH600X



60CM CANOPY RANGE HOOD



TECHNICAL DIAGRAM

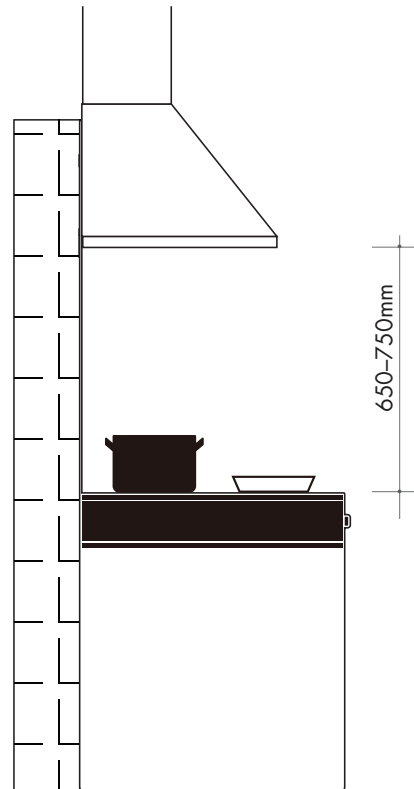
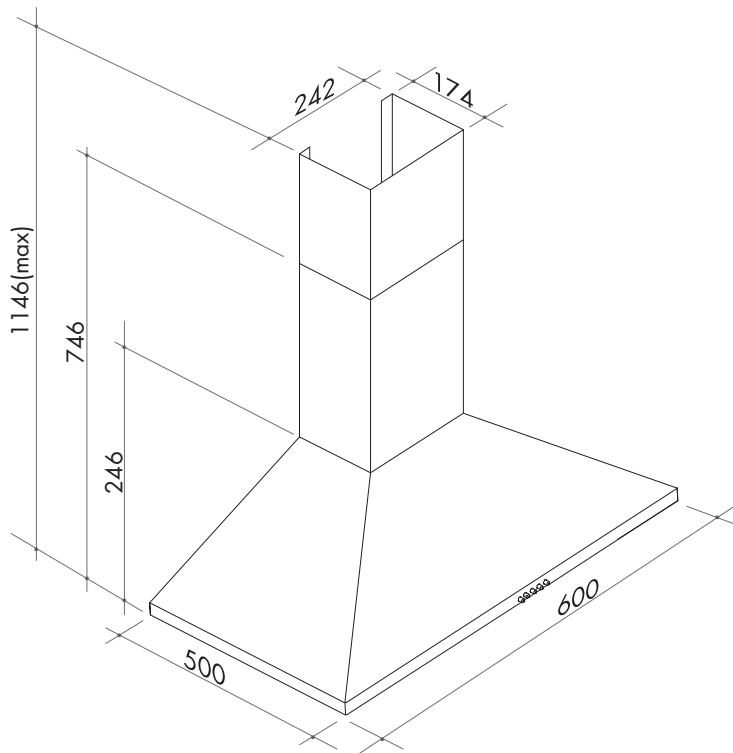

NB: drawings are not to scale — they are to be used for detailed installation instructions, please refer to user guide.

EAN 9347777000682

AR10092018

DISCLAIMER

Eurolinx PTY LTD, is continually seeking ways to improve the design specifications, aesthetics and production techniques of its products. As a result alterations to our products and designs take place continually. Whilst every effort is made to produce information and literature that is up to date, this brochure should not be regarded as an infallible guide to the current specifications, nor does it constitute an offer for the sale of any particular product. Product dimensions indicated in our literature is indicative only. Actual product only should be used to define dimension cut outs. Distributors, and retailers are not agents of Eurolinx and are not authorized to bind Eurolinx by any express or implied undertaking or representation.

ACH600X Canopy Range Hood

240W input power

160W maximum motor power

Electrical connection: 10AMP GPO

ARTUSI SHOWROOMS ARE OPEN TUESDAY TO FRIDAY FROM 9AM-5PM AND SATURDAYS 10AM-4PM (MELBOURNE TUE-SAT 9.30AM - 4PM)

NSW & ACT
(HEAD OFFICE)

48 MOORE STREET
LEICHHARDT

VIC | SA

1211 TOORAK ROAD
CAMBERWELL

TASMANIA

3 PEAR AVENUE
DERWENT PARK

QLD

1/42 CAVENDISH ROAD
COORPAROO

WA | NT

10/55 HOWE STREET
OSBORNE PARK

NEW ZEALAND

CHRISTCHURCH
P: 03 344 5913
ARTUSI.CONZ

P: 1300 649 583

ARTUSI.COM.AU