

Thanks for purchasing a 9.Solutions product. With great passion, we design our products to be as versatile as possible. We hope that our products contribute to your creative vision.

Sincerely,

The 9.Solutions Team

9.SOLUTIONS

LARGE VESA TO 5/8" RECEPTACLE

SPECIFICATIONS:

Weight: 570 g

Max Load: 30 kg

Connection(s):

(1x) 75x75mm VESA Pattern

(1x) 100x100mm VESA Pattern

(1x) 100x200mm VESA Pattern

(1x) 200x200mm VESA Pattern

(2x) 5/8" Receptacle

(1x) 1/4"-20 Female Thread

(1x) 3/8"-16 Female Thread

Package Content(s):

(1x) Large VESA to 5/8" Receptacle

Large VESA to 5/8" Receptacle is compatible with monitors featuring 75x75, 100x100, 100x200 and 200x200 hole patterns.

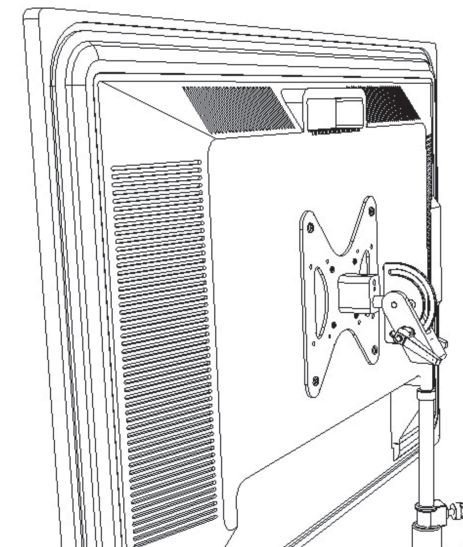
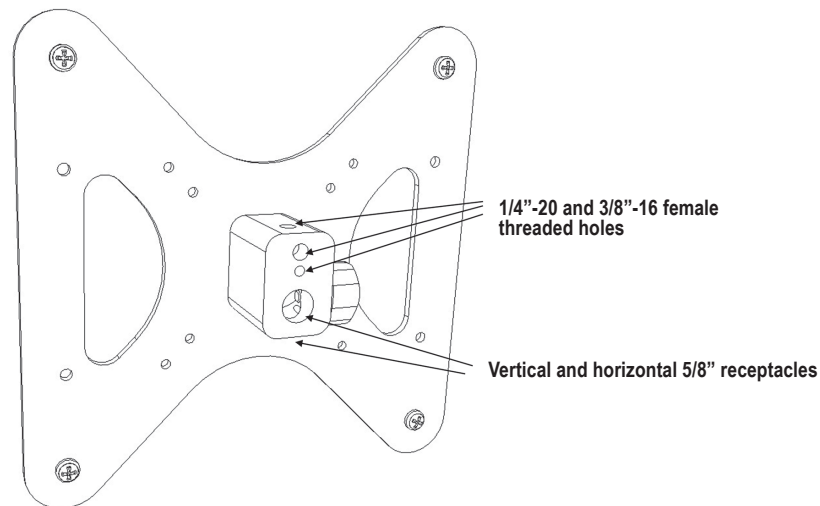

Always follow the safety standards and regulations of the given country where the product is being used.

Visit www.9.solutions for more info.