

Thanks for purchasing a 9.Solutions product.  
With great passion, we design our products to  
be as versatile as possible. We hope that our  
products contribute to your creative vision.

**9.SOLUTIONS**  
5/8" DUAL GAG

Sincerely,

The 9. Solutions Team

**SPECIFICATIONS:**

Weight: 340 grams

Connection(s):

(2x) 5/8" (16mm) Pass-thru Receptacle

(2x) 3/8" (10mm) Pass-thru Receptacle

Package Contents:

(1x) 5/8" Dual Gag

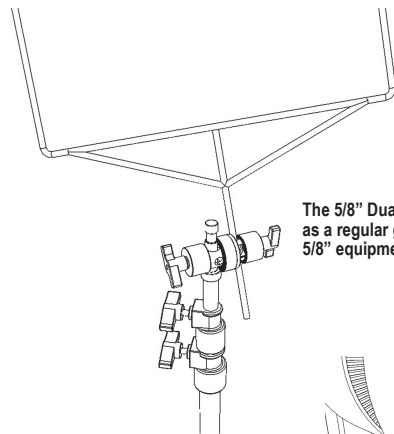

The 5/8" Dual Gag can be used  
as a regular grip head on standard  
5/8" equipment like stands.

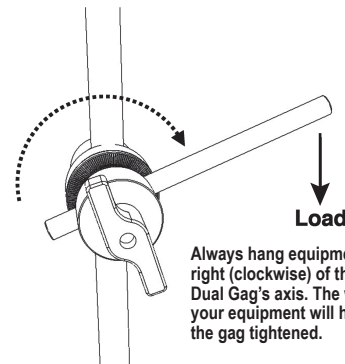

Always hang equipment to the  
right (clockwise) of the 5/8"  
Dual Gag's axis. The weight of  
your equipment will help keep  
the gag tightened.

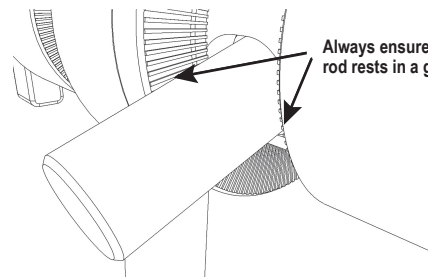

Always ensure that the clamped  
rod rests in a groove.

Always follow the safety standards and regulations of the given country where the product is being used.

Visit [www.9.solutions](http://www.9.solutions) for more info.