



# **Gauge Mounting Arm Installation Instructions**

**2019-2022 Ram**

---

## Materials

---

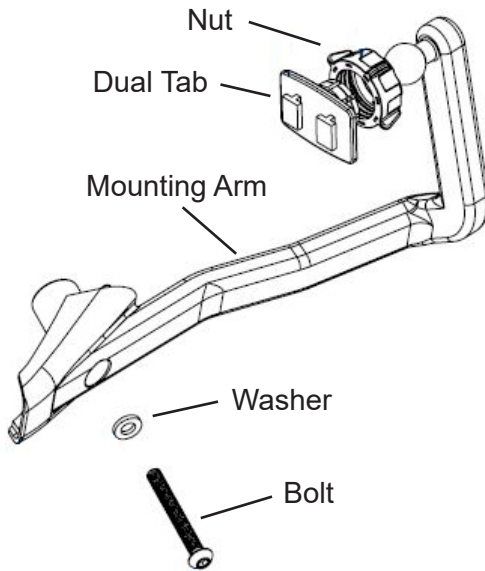

---

## Required Tools

---

- 10 mm 1/4" drive Socket, deep or regular
- 3 1/4" Drive Extension
- 1/4" Drive Socket Wrench
- Small 1/7" Flat-blade Screwdriver
- 4 mm Allen Wrench

---

## Mounting Arm Installation

---

1. On the driver's side A-pillar grab handle, carefully remove the lower cover by prying it loose using a screwdriver.
2. Remove the exposed bolt. Keep the cover and bolt should you wish to return the vehicle to stock.
3. Using the hardware included with the mounting arm, install the flat washer on the bolt and insert the bolt through the mounting arm.
4. Insert the mounting arm into the hole and use an Allen wrench to tighten the bolt into the pillar.
5. Remove the dual tab and nut from the bag. If the dual tab and nut are screwed together, unscrew them slightly from one another until the nut moves freely.
6. Snap the nut and dual tab over the ball on the mounting arm and tighten the nut (if the nut won't go onto the ball, the tab and nut may need to be unscrewed further).
7. Attach your device to the dual tab and secure the cord. Adjust the device position using the dual tab/nut.

Before



After



*For additional questions not found in the user guide, call:*

**Holley Technical Support: (888)-360-3343**

Mon - Fri 8:00 am - 5:00 pm MST, Sat 8:00 am - 2:00 pm MST

**To expedite your support call, please have your Vehicle Information,  
Part Number, and Serial Number ready prior to calling Technical Support.**

**Holley**<sup>®</sup>  
TUNING GROUP

© Copyright 2022 Holley Inc. and subsidiaries. All rights reserved.

D10026500 Rev02 11/08/2022