

Installation Manual

VERSION
FRANÇAISE



10358 KIT

Ford F150 (4WD)*

Use the most advanced air springs on the market to eliminate your vehicle's sag, sway and bottoming out. This heavy duty air suspension kit levels your truck's stance while providing added support for an overall smooth and safe ride.

* See application guide for proper fitment.

L6497_REV6_05.02.2022



WARNING: This product can expose you to the chemical Hexavalent Chromate, which is known to the State of California to cause cancer and birth defects or other reproductive harm. *For more information go to www.P65Warnings.ca.gov*

IMPORTANT

This air suspension kit will not increase the GVWR (*Gross Vehicle Weight Rating*), as the GVWR is determined by the vehicle manufacturer. **Do not exceed the maximum capacity listed by the vehicle manufacturer.**

PLEASE NOTE: *The air bag must have clearance between itself and the surrounding components to prevent any contact when bag is inflated or compressed. Trimming off excess bolt length is also required to ensure no contact with the bag or other suspension components can be made once installed.*

Safety Warnings!

- ❗ Serious personal injury or death may result from an air spring failure or accident due to improper installation or air spring pressure operation or maintenance. Please read and abide the instructions, safety recommendations and maintenance suggestions throughout this manual.
- ❗ Inflating an unsecured air spring is dangerous. If it bursts, it could be hurled into the air with explosive force resulting in serious personal injury or death. Never inflate an air spring unless it is secured to the vehicle.
- ❗ Removing and replacing air springs can be dangerous. This is only a job for a qualified service professional. Never perform air spring service procedures without proper training, tools, and equipment.

KIT CONTENTS

Reference the kit explosion diagram on the following page for part assembly.

KIT CONTENTS			QTY	PART #	REQUIRED TOOLS	
A	Air Spring	2	HP10000	•	Hoist or Floor Jack	
B	Upper Frame Bracket (Driver Side)	1	HP1590	•	Safety Stands	
C	Upper Frame Bracket (Passenger)	1	HP1591	•	Safety Glasses	
D	Upper Airbag Bracket	2	HP1594	•	Torque Wrench	
E	Lower Bracket, Driver	1	HP1592	•	Standard Combination Wrenches	
F	Lower Bracket, Passenger	1	HP1593	•	7/32" Hex Allen Wrench	
G	Leaf Spring Clamp Bar	4	HP1623	•	1-1/8" Wrench or Deep Socket	
H	Roll Plate	4	HP10054	•	Ratchet	
I	M10 x 1.5 x 45 mm Bolt	2	HP1341	•	Metric & Standard Sockets	
J	3/8"– 16 x 1.25" Carriage Bolt	4	HP1149	•	Hose Cutter (included) or Sharp Utility Knife	
K	3/8"– 16 x 3.50" Carriage Bolt	8	HP1332	•	Pipe Thread Sealant	
L	3/8"– 16 Nylon Locknut	20	HP1000	•	Spray Bottle with Dish Soap/Water	
M	3/8"– 16 x 1.25" Hex Cap Bolt	8	C10464	•	Air Compressor/Compressed Air Source (to test/fill air springs)	
N	3/8"– 24 x 7/8" Hex Cap Bolt	8	HP1002			
O	3/8" Flat Washer	30	C18006			
P	3/8" Lock Washer	8	C18007			
Q	Carriage Bolt Lock Bracket	4	HP0123			
R	90° Swivel Air Fitting	2	HP1100			
S	Air Line Assembly (<i>not shown</i>)	1	HP1344			
T	Tie Strap (<i>not shown</i>)	6	C11618			
U	Bolt Leader Tool (<i>not shown</i>)	2	HP1440			

Please make sure all the items shown in this explosion diagram are provided in your kit before starting the installation.

DRIVER SIDE ASSEMBLY SHOWN:

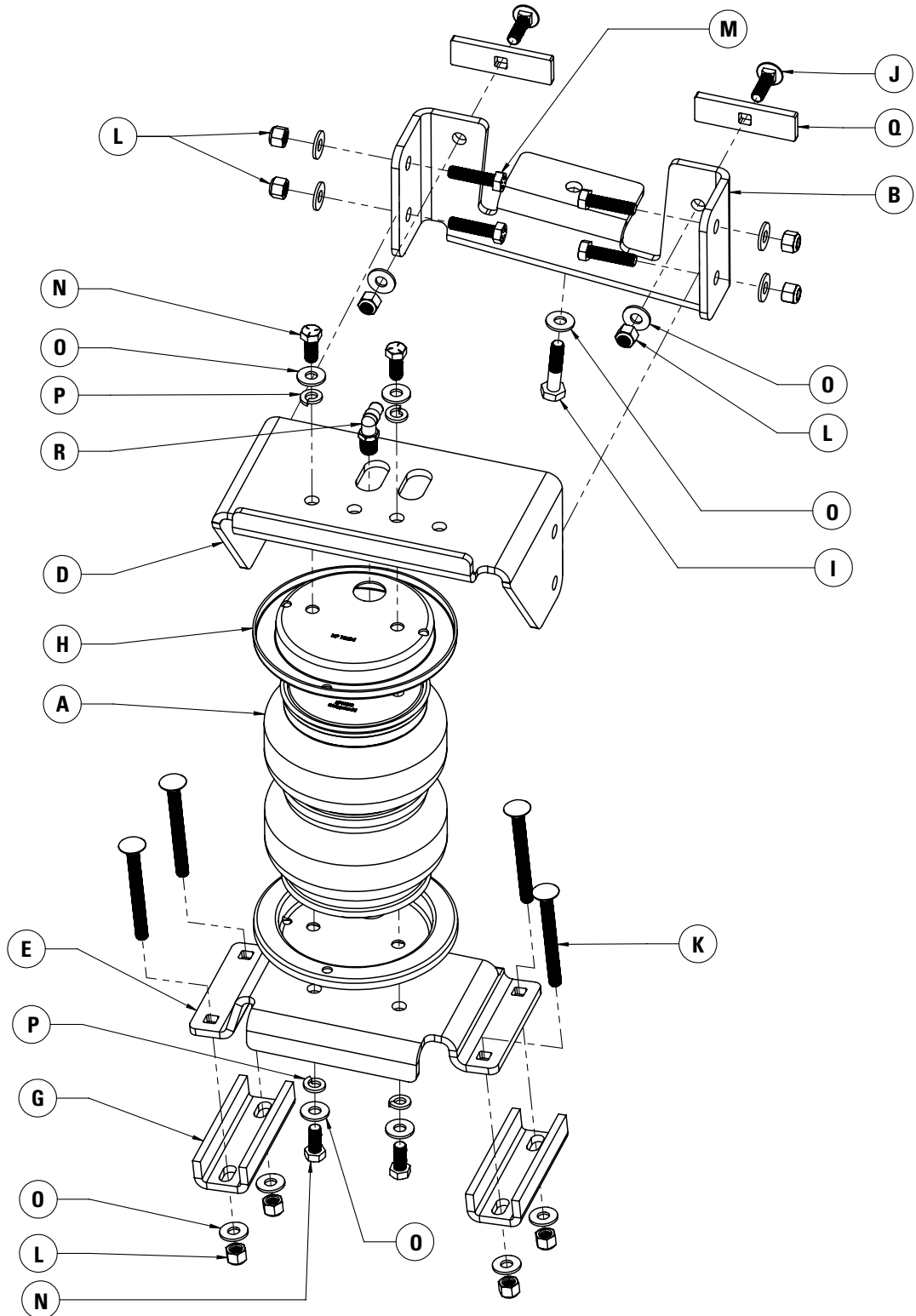

BEFORE STARTING THE INSTALLATION:

1. Ensure the application information is correct for the make, model and year of the vehicle you are installing the kit on.
2. Some vehicles are equipped with a rear wheel brake proportioning valve. Check with the manufacturer before installing the air spring kit, as it may affect braking performance.
3. It is recommended to use a good quality anti-seize on all fasteners. This will reduce the chance of corrosion on the fasteners and will help facilitate removal, if required at a later date.

PLEASE NOTE:

This kit contains push-to-connect fittings; using scissors or wire cutters to cut the nylon airline will distort the line and cause the connection to leak. THE AIRLINE MUST BE CUT OFF SQUARELY WITH THE NYLON HOSE CUTTER PROVIDED IN THIS KIT OR A SHARP UTILITY KNIFE.

1 MEASURE STOCK RIDE HEIGHT

Park the vehicle on a level surface.

Using a measuring tape, measure the distance between the center of the wheel hub and the bottom of the fender well (as shown in Figure 1) this will give you your ride height.

Note the ride height for all four corners.

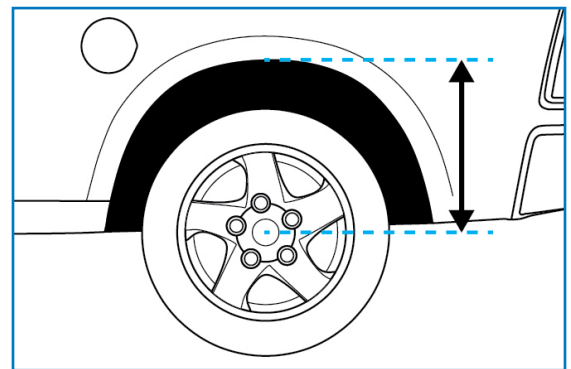

1

2 REMOVE REAR WHEELS

Place wheel chocks in front of and behind both front wheels.

Raise the rear of the truck high enough to remove both wheels and attain a comfortable working height.

Place two jack stands under rear axle (shown in Figure 2).

Lower the vehicle until the axle is supported by the jack stands.

Remove rear wheels.



2

3 REMOVE THE JOUNCE BUMPER

The jounce bumper assembly (shown in Figure 3) consists of a cup and a bumper. It is bolted to the frame with a single bolt running through the center of the jounce bumper.

Remove the bolt holding the jounce bumper to the frame with a 13 mm socket. A socket extension may be required to reach the bolt.

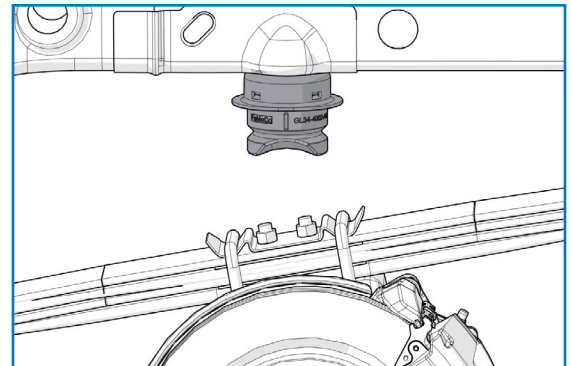

4 ATTACH THE UPPER BRACKET TO THE FRAME

Assemble the upper bracket (B) as shown in Figure 4A.

Place the upper frame bracket on the frame rail and position by inserting the M10 x 1.5 x 45 mm bolt (I) through the locating hole in the bottom of the bracket into the jounce bumper bolt hole.

Torque the M10 bolt to 30 ft-lbs (41 N-m).

Insert a 3/8" – 16 x 1.25 carriage bolt (J) through a carriage bolt locking bracket (Q). Insert the bolt and bracket combination through the oval hole on the rear side of the frame and align with the mounting holes. Fishing wire may be needed to pull the bolt and bracket combination through the frame.

Secure the bracket to the frame using two 3/8" – 16 nylock nuts (L) and two 3/8" flat washers (O).

Torque the nylock nuts to 20 ft-lbs (27 N-m).

A correctly attached bracket should appear as shown in Figure 4B.

Repeat on opposite side

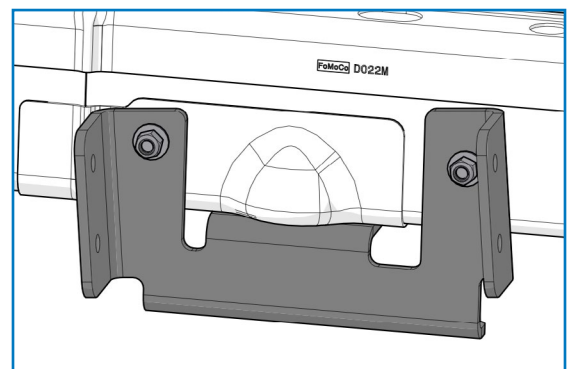
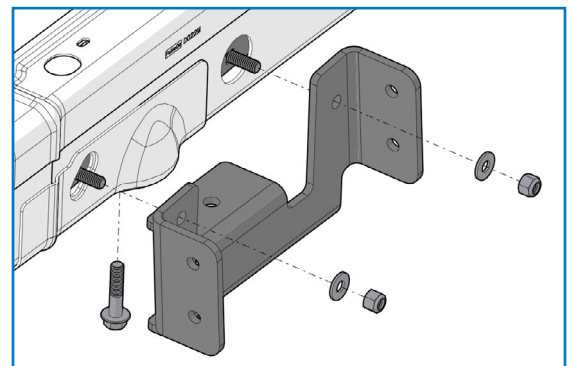

5 ASSEMBLE THE AIR SPRINGS AND BRACKETS

Set the roll plate (H) over the over the bottom of the air spring (A).

Set the lower spring bracket (E) onto the air spring ensuring that the holes in the air spring, roll plate and lower bracket all line up.

Fasten the assembly together using two 3/8" – 24 x 7/8" hex cap bolt (N), two 3/8" lock washers (P) and two 3/8" flat washers (O). Torque the mounting hardware to 20 ft-lbs (27 N-m).

Turn the assembly over and set the roll plate (H) over the top of the air spring.

Fasten the swivel fitting (R) into the top of the air spring. It is recommended to use Teflon tape or some form of thread sealant to prevent air leaks. Finger tighten the swivel fitting and turn an extra 1.5 turns to tighten

Set the upper airbag bracket (B) onto the air spring ensuring that the holes in the air spring, roll plate and bracket all line up.

Fasten the assembly together using two 3/8" – 24 x 7/8" hex cap bolt (N), two 3/8" lock washers (P) and two 3/8" flat washers (O). Torque the mounting hardware to 20 ft-lbs (27 N-m).

Repeat for the other air spring.

6 INSTALL THE AIR SPRING ASSEMBLIES

Note: It may be necessary to raise the frame of the truck a few inches to allow more clearance to install the air spring assemblies.

Place the air spring assembly onto the truck with the lower bracket sitting on the leaf spring and the upper airbag bracket between the extended arms of the upper frame bracket (shown in Figure 6).

Attach the upper airbag bracket to the upper frame bracket using four 3/8" – 16 hex bolts (M), four 3/8" flat washers (O) and four 3/8" – 16 nylock nuts (L).

Torque the mounting hardware to 20 ft-lbs (27 N-m).

Repeat for the opposite side

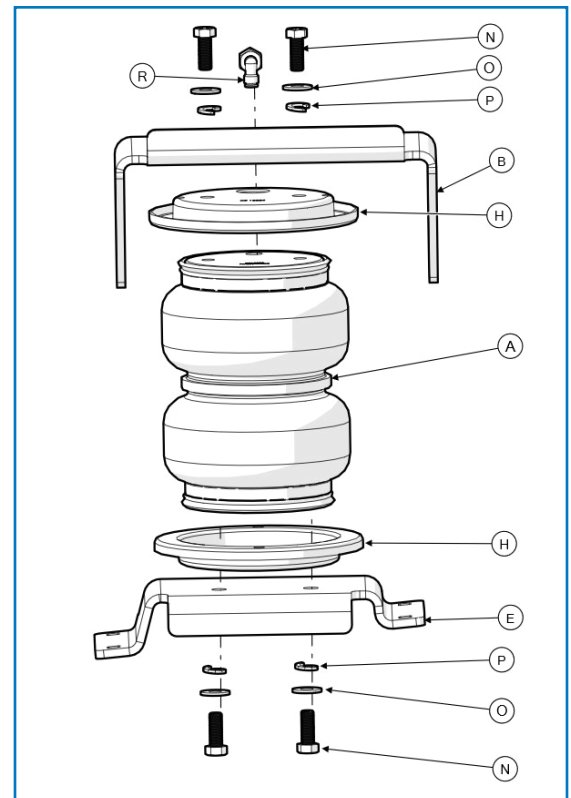

5

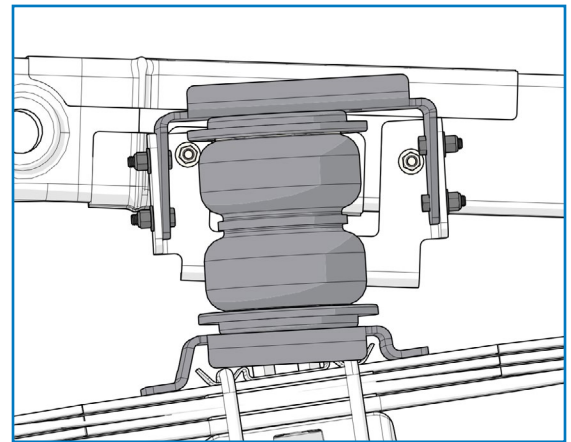

6

7 ATTACH LOWER BRACKETS TO LEAF SPRINGS

Insert four 3/8" – 16 x 3.50" carriage bolts (K) into the mounting holes in the lower bracket (as shown in Figure 7).

Clamp the lower bracket to the leaf spring using the leaf spring clamp bar (G). Secure using four 3/8" – 16 nylon locknuts (L) and four 3/8" flat washers (O).

Torque the locknuts to 20 ft-lbs (27 N-m).

Repeat on opposite side

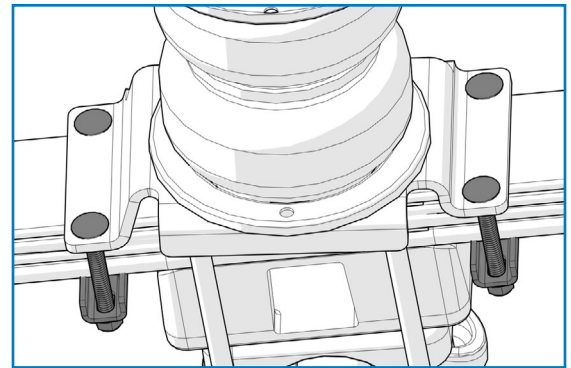

7

8 INSTALL AIR LINE

PLEASE NOTE: This kit contains push-to-connect fittings; using scissors or wire cutters to cut the nylon airline will distort the line and cause the connection to leak. THE AIRLINE MUST BE CUT OFF SQUARELY WITH THE NYLON HOSE CUTTER PROVIDED IN THIS KIT OR A SHARP UTILITY KNIFE

Provided in air spring kit are two fill valves. The most common place to install is in place of license plate fasteners. Alternatively, two 5/16" holes can be drilled in a convenient location.

Cut air line assembly into two equal lengths with hose cutter.

Install one air line, route the nylon air line to an air spring fitting and cut the hose. Moisten the end of the air line prior to inserting it into the fitting and push it in until it stops. Repeat with the other fill valve.

Secure airlines using the tie-straps, away from moving items and heat sources.

Place a 5/16" nut on the air valve. Leave enough of the inflation valve in front of the nut to extend through the hole, install a flat washer, and 5/16" nut and cap (reference Figure 8 for assembly). There should be enough valve exposed after installation—approximately 1/2"—to easily apply a pressure gauge or an air chuck.

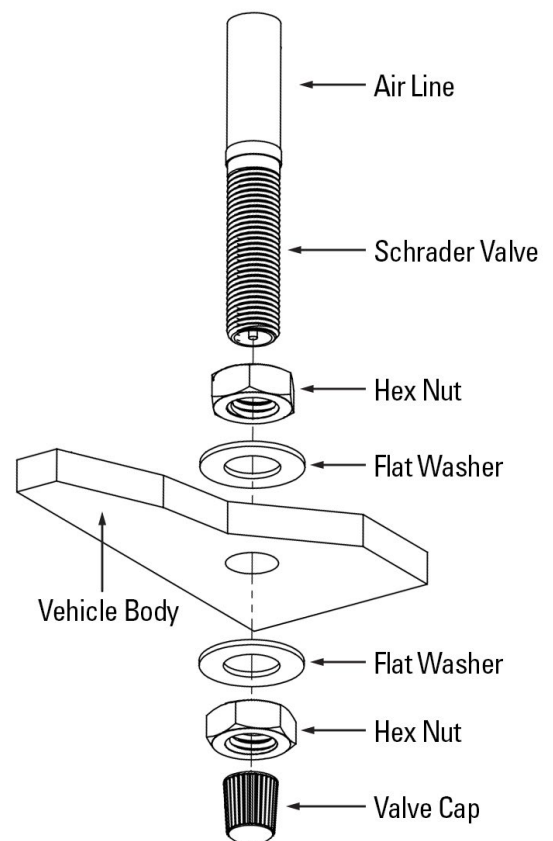

8

If an in-cab inflation kit is being installed, follow the instructions provided with that kit now.

9 CHECK SYSTEM FOR LEAKS

Inflate both air springs to 90 psi and then use a mixture of dish soap and water on all air line connections to detect any air leaks. Large, expanding bubbles indicate a leak (as shown in Figure 9). Repair as necessary and retest.

Inflate air springs to a predetermined value and on following day recheck pressure. If one or both of air springs have lost pressure, an air leak is present. Leak must be repaired, and then retested until no leaks exist.

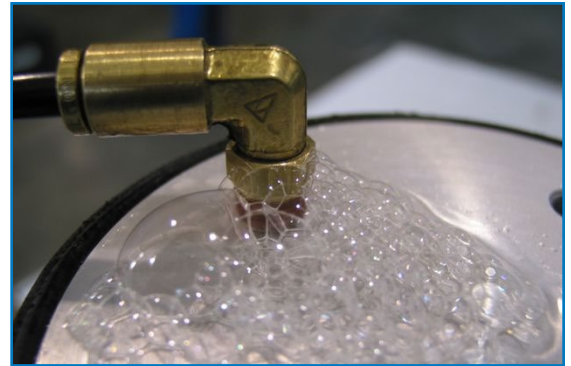

9

10 AFTER COMPLETING THE INSTALLATION

PLEASE REMEMBER:

Install wheels and torque fasteners to manufacturer's specifications.

Re-torque all fasteners after first 500 miles of driving.

For safe and proper operation, never operate the vehicle under minimum of 10 psi or over maximum of 100 psi in air springs. Staying within pressure limit will ensure maximum air spring life. Failure in doing so may result in a void warranty (see **Note** below).

NOTE: Do not exceed maximum vehicle payload. Failure to do so may result in failure of the air suspension kit and/or damage to your vehicle.

Thank you again, and congratulations on the installation of the air suspension kit.

OPTIONAL ACCESSORIES

Optional dual needle air gauges are available to monitor pressure in each spring from vehicle cab, as well as a full line of air compressors, air tanks, and solenoids built to work with and control your air spring system.

OPERATING YOUR VEHICLE WITH AIR SUSPENSION

Air springs have minimum and maximum pressure requirements. Never operate your vehicle with less than 10 psi in air spring and never inflate air springs over 100 psi. Damage to air springs will result.

Check air pressure in air springs daily for first couple of days to ensure a leak has not developed. Air springs are designed to maintain the vehicles stock ride height with a load. Do not use the air springs as a means to lift vehicle with no load. This will result in a harsh ride.

SERVICING YOUR VEHICLE WITH AIR SUSPENSION

When lifting the vehicle with a floor jack or hoist on the frame, never allow the air spring to limit the travel of the axle. Try to always jack the vehicle on the axle. Suspending the axle with the air spring limiting the axle travel will damage the air spring and void the air spring warranty.

WARRANTY

To be eligible for warranty, the owner must submit their warranty card or register online within 30 days of the purchase date.

NOTE: The owner's warranty will be void if air springs are run with less than the minimum of 10 psi.

