

Installation Manual



AIR SUSPENSION KIT

Ford F250/F350 Super Duty (2WD/4WD), ¾ & 1 Ton*

**Will not fit 2010-2012 vehicles with factory installed 5th wheel hitch*

**Will fit with a Draw Tite 15000 5th wheel hitch*

Use the most advanced air springs on the market to eliminate your vehicle's sag, sway and bottoming out. This heavy duty air suspension kit levels your truck's stance while providing added support for an overall smooth and safe ride.

** See application guide for proper fitment.*

L5754_REV19_02.22.2024

Thank you and congratulations on the purchase of an Air Suspension kit. Please read the entire manual prior to starting the installation to ensure you can complete it once started.

IMPORTANT

This air suspension kit will not increase the GVWR (*Gross Vehicle Weight Rating*), as the GVWR is determined by the vehicle manufacturer. **Do not exceed the maximum capacity listed by the vehicle manufacturer.**

For safe and proper operation of the vehicle, never exceed a maximum of 100PSI in the air springs. Staying under the pressure limit will ensure maximum air spring life. **Failure in doing so may result in damage to your vehicle and/or a void warranty.**

SAFETY WARNINGS!

! Please read and abide the instructions found in this manual, paying close attention to the helpful, cautionary or dangerous warning icons highlighting important safety recommendations and maintenance suggestions throughout this manual.

+ **HELPFUL INSTALL TIP**
Additional information that could potentially make the job a little easier.

! **PLEASE USE CAUTION**
Unsafe practices could result in damage to you or your vehicle, or others.

! **DANGER WARNING**
Hazards which could result in severe personal injury or death.

! Serious personal injury or death may result from an air spring failure or accident due to improper installation or air spring pressure operation or maintenance.

! Inflating an unsecured air spring is dangerous. If it bursts, it could be hurled into the air with explosive force resulting in serious personal injury or death. Never inflate an air spring unless it is secured to the vehicle.

! Removing and replacing air springs can be dangerous. This is only a job for a qualified service professional. Never perform air spring service procedures without proper training, tools, and equipment.

BEFORE STARTING THE INSTALLATION

- Ensure the application information is correct for the make, model and year of the vehicle you are installing the kit on.
 - Some vehicles are equipped with a rear wheel brake proportioning valve. Check with the manufacturer before installing the air spring kit, as it may affect braking performance.
 - Check the vehicle to see if it is equipped with a 5th Wheel Hitch. Some 5th wheel hitches require brackets to be mounted to the frame in the same locations as the air spring brackets (if this is the case, modifications of the 5th wheel hitch brackets may be required to mount this kit). **Please contact your point of purchase if you have questions**
 - Check the clearance between the outside of the frame and the inside of the tire, a minimum of 8" is required for air spring clearance.
 - Some vehicles are equipped with a rear wheel brake proportioning valve. Check with the manufacturer before installing the air spring kit, as it may affect braking performance.
 - It is recommended to use a good quality anti-seize on all fasteners. This will reduce the chance of corrosion on the fasteners and will help facilitate removal, if required at a later date.
- !** **PLEASE NOTE: This kit contains push-to-connect fittings; using scissors or wire cutters to cut the nylon air line will distort the line and cause the connection to leak. The air line must be cut off squarely with the hose cutter provided in this kit, or a sharp utility knife. Failure to do so may void the warranty.**

KIT CONTENTS

Please confirm the items below are provided in your kit before starting the installation.

HEAVY DUTY KITS		QTY	PART #
A*	Double Convoluted Spring	2	HP10000

HEAVY DUTY JOUNCE BUMPER KITS		QTY	PART #
A*	Double Convoluted Spring w/ Jounce Bumper	2	HP10000J

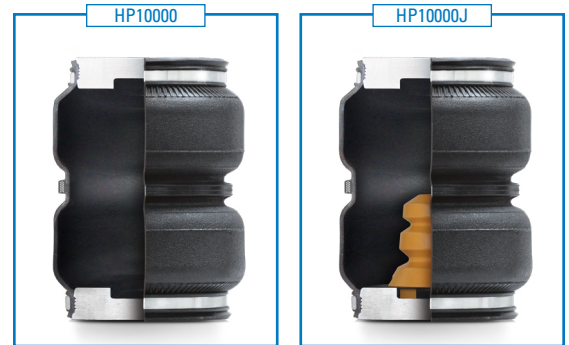

.....

KIT CONTENTS		QTY	PART #
A	Air Springs	2	HP10000
B	Upper Brackets	2	HP0140
C	Lower Brackets	2	HP0104
D	Roll Plates	4	HP10054
E	Spacer Bracket	4	HP0028
F	5/16" x 18 Nylock Nut	1	C11943
G	3/8" NC x 6 1/2" bolts	4	HP1018
H	3/8" NC x 1 1/2" bolts	8	C18018
I	3/8" NF x 7/8" capscrews	8	HP1002
J	3/8" Flat Washers Large O.D.	8	HP1013
K	3/8" Lock Washer	8	C18007
L	3/8" Flat Washer Small O.D.	24	C653
M	3/8" Nylock Nuts	16	HP1000
N	5/16" x 18 x 1 Flangehead Bolt	1	C11819
O	Air Line/Valve Assembly	1	HP1344
P	Tie Straps	6	C11618

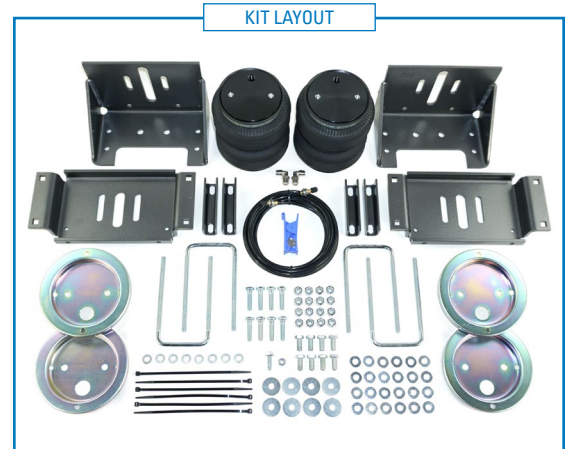

REQUIRED TOOLS

- Hoist or Floor Jack
- Safety Stands
- Safety Glasses
- Torque Wrench
- Standard Combination Wrenches
- 7/32" Hex Allen Wrench
- Ratchet
- Metric & Standard Sockets
- Hose Cutter (included) or Sharp Utility Knife
- Pipe Thread Sealant
- Hacksaw
- "C" Clamps
- Spray Bottle with Dish Soap/Water
- Air Compressor/Compressed Air Source (to test/fill air springs)

WARNING: This product can expose you to the chemical Hexavalent Chromate, which is known to the State of California to cause cancer and birth defects or other reproductive harm. For more information go to www.P65Warnings.ca.gov

INSTALLATION INSTRUCTIONS

1 MEASURE STOCK RIDE HEIGHT

Park the vehicle on a level surface. Remove any unnecessary weight from the vehicle to attain a Normal Ride Height. This is important for correct initial air spring set-up and adjustment.

Using a measuring tape, measure the distance between the center of the wheel hub and the bottom of the fender well (as shown in Figure 1) this will give you your ride height.

Note the ride height for all four corners.

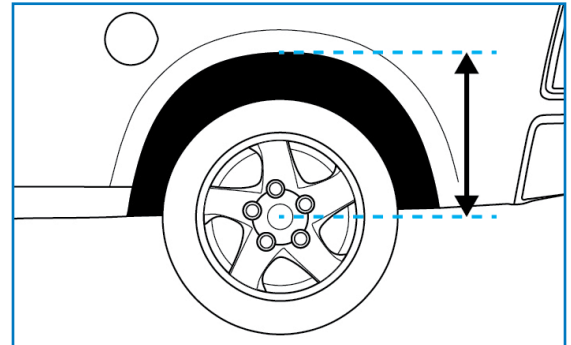

1

2 REMOVE REAR WHEELS

Place wheel chocks in front of and behind both front wheels.

Raise the rear of the truck high enough to remove both wheels and attain a comfortable working height.

Place two jack stands under rear axle (shown in Figure 2).

Lower the vehicle until the axle is supported by the jack stands.

Remove rear wheels.



2

3 LOWER BRACKET ASSEMBLY

Locate the end of the air spring with the 1/8" NPT air port (shown with an arrow in Figure 3A), place this side down with the air port away from you.

Place the roll plate over the end of the air spring, aligning the two mounting holes (rounded end towards the air spring). Then, place the lower mounting bracket with the flange towards you over the roll plate and air spring aligning the two mounting holes.

Using the two 3/8 NF x 7/8 capscrews, lock washers and flat washers, loosely fasten the assembly together (as shown in Figure 3B).

Do not tighten the capscrews fully until final adjustment is performed in Step 8.

Repeat on other side.

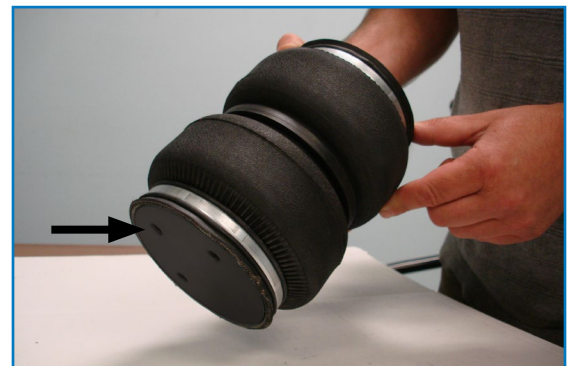

3A



3B

- 4 Remove the emergency brake cable fastener on the driver side.

Note the two pre-existing holes in the frame, shown by arrows in Figure 4A.

! *For 2008-2010 model year trucks: all 4 mounting holes are required to be drilled.*

Fasten the upper bracket through the two rear holes in the air spring bracket and the two pre-existing holes in the frame (as shown by the arrows in Figure 4B). Use the 3/8 NC x 11/2 bolts (small O.D. 3/8 flat washer under the bolt head, large O.D. 3/8 flat washer on the inside of the frame) and then install the nylock nut provided.

Do not tighten the bolts fully until a final adjustment is performed in Step 8.

! *For Driver Side only: two holes are provided in the top rear upper bracket for the emergency brake cable clamp.*

Use the 5/16" flange bolt and nylock nut provided to fasten the original emergency brake clamp to the air spring bracket.

Install the bolt with the head down, so the nut is on top of the bracket.

- 5 Insert the lower air spring assembly with air spring between the leaf spring and the upper bracket. Center the lower bracket above the center of the axle tube.

Using Figure 5 as reference, check the alignment of the air spring top to the upper bracket and adjust the upper bracket so that it is parallel to the top of the air spring.

Clamp the forward side of the upper air spring bracket to the frame in the correct position.

- 6 Remove the lower air spring assembly with air spring.

Using the two forward holes in the upper bracket as a guide, drill the two front holes through the upper air spring bracket in the frame with a 3/8" drill bit (see Figure 6 for reference).

Install the two forward 3/8 NC x 11/2 bolts (small O.D. washer under the bolt head, large O.D. 3/8 washer on the inside of the frame) and install the nylock nut provided.

Torque all 4 fasteners to 40 ft-lbs.



4A

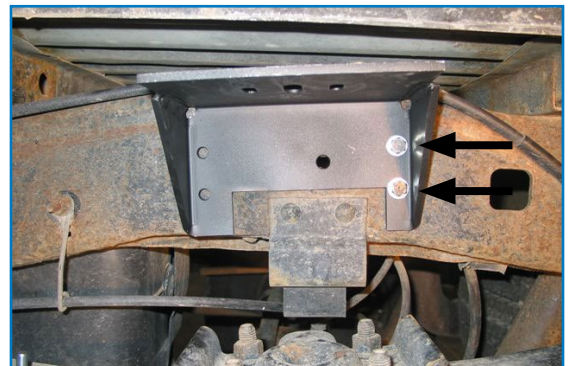

4B

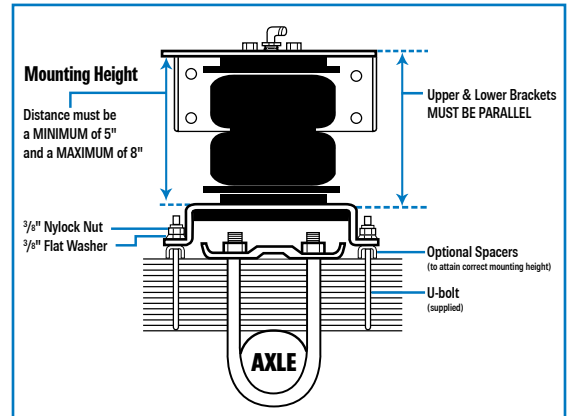

5



6

- 7 Install the 90° fitting in the top of the air spring using thread sealant, as shown in Figure 7. Do not over-tighten the fitting.

Install the upper roll plate (rounded side towards air spring), aligning it to the 2 remaining mounting holes.

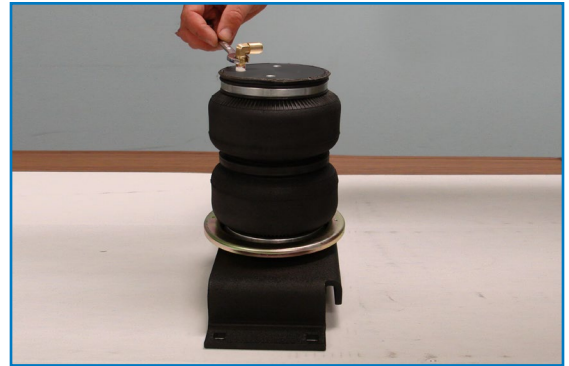

7

- 8 Insert the lower air spring assembly with air spring, aligning the air fitting with the center hole in the upper bracket. Loosely install the correct U-bolts around the leaf spring pack to center the lower bracket on the leaf. Make sure the center of the air spring is centered over the axle tube.

Loosely install the two upper capscrews, lock and flat washers through the bracket and roll plate into the air spring. The air spring mounting bracket holes are slotted to adjust the clearance between the frame and the air spring. 1" is the minimum clearance allowable between the air spring and the frame. Adjust the lower end of the air spring on its mounting bracket so that the air spring is in the correct alignment, (see Figure 8B on following page).

Once the correct clearance and alignment is attained, torque the air spring fasteners to the upper and lower brackets.

Torque the capscrews to 20 ft-lbs.



8A

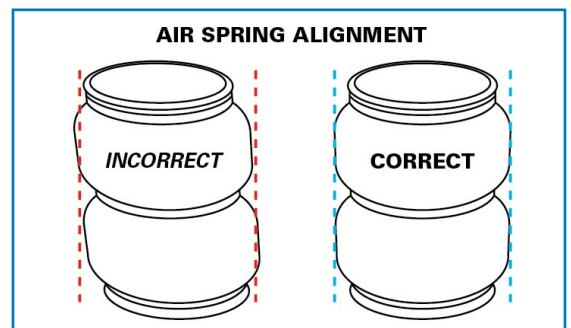

8B

- 9 Install the correct U-bolts around the leaf spring pack using the flat washers and nylock nuts provided. (See Figure 9)

Ensure the lower air spring bracket is centered over the axle tube before tightening the U-bolt nuts.

Cut off the threaded portion of the U-bolt above the nyloc nut.

Torque evenly to 16 ft-lbs.

Repeat Steps 4-9 on the passenger side.



9

INSTALL AIR LINE

Two fill valves are provided in this kit. The most common place to install them is in place of the license plate fasteners. Alternatively, two 5/16" holes can be drilled in a location of your choosing.

Cut the air line assembly into two equal lengths with the hose cutter provided in this kit or a sharp utility knife.

! **PLEASE NOTE:** *This kit contains push-to-connect fittings; using scissors or wire cutters to cut the nylon air line will distort the line and cause the connection to leak. The air line must be cut off squarely with a hose cutter or a sharp utility knife.*

Install one air line at a time starting at the fill valve location. Place a 5/16" nut on the air valve. Leave enough of the inflation valve in front of the nut to extend through the hole, install a flat washer, and 5/16" nut and cap (reference Figure A for assembly). There should be enough valve exposed after installation – approximately ½" – to easily apply a pressure gauge or an air chuck.

Route the air line back to the NPT fitting on the air spring, then cut the hose to length. Moisten the end of the air line prior to inserting it into the fitting and push it in until it stops.

Repeat with the other fill valve.

Secure the air lines using the provided tie-straps, away from any moving items and heat sources.

CHECK SYSTEM FOR LEAKS

Inflate both air springs to 90 psi and then use a mixture of dish soap and water on all air line connections to detect any air leaks. Large, expanding bubbles indicate a leak (as shown in Figure B).

Repair as necessary and retest.

Inflate air springs to a predetermined value and on following day recheck pressure. If one or both of air springs have lost pressure, an air leak is present.

! **Leak must be repaired, and then retested until no leaks exist.**

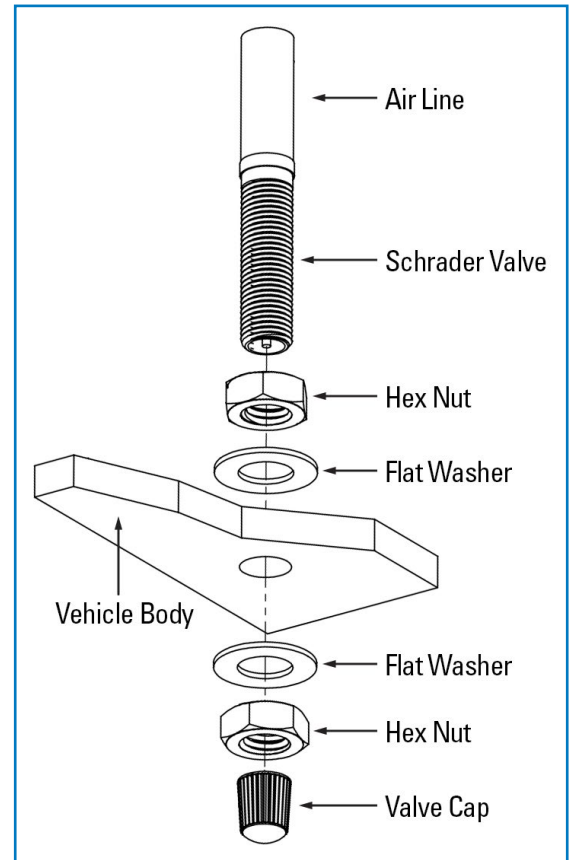

A

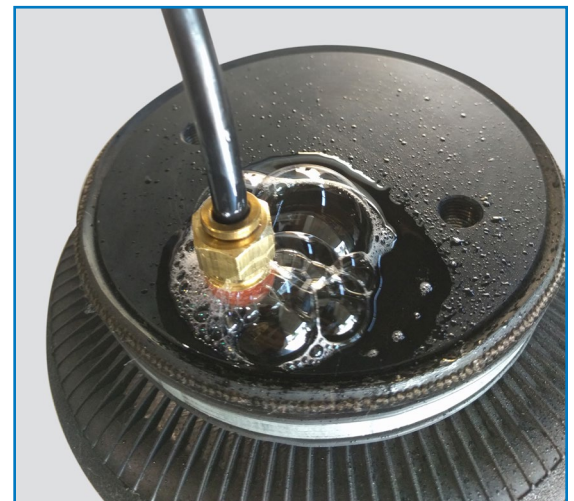

*Air Spring & NPT Air Fitting may differ between kits

B

CONGRATULATIONS! You have completed the install

After Installation continues on the following page.

.....

Thank you again, and congratulations on the installation of your Air Suspension kit.

AFTER COMPLETING THE INSTALLATION

- The air spring must have clearance between itself and the surrounding components to prevent any contact when spring is inflated or compressed. Trimming off excess bolt length may also be required to ensure no contact with the spring or other suspension components can be made once installed.
- If removed, re-install the wheels and torque fasteners to the manufacturer’s specifications. Re-torque all fasteners after the first 500 miles of driving.

OPERATING YOUR VEHICLE WITH AIR SUSPENSION

Air springs have minimum and maximum recommended pressure requirements:

PART #	SPRING STYLE	SPRING TYPE	MIN PSI	MAX PSI
HP10189	In-Coil	STANDARD DUTY	5 PSI	70 PSI
HP10560		STANDARD DUTY		
HP10001	Sleeve Style	STANDARD DUTY	10 PSI	100 PSI
HP10173		STANDARD DUTY		
HP10199		STANDARD DUTY		
HP10083	Single Convoluted	HEAVY DUTY	5 PSI	100 PSI
HP10083J		HEAVY DUTY with JOUNCE BUMPER	0 PSI* / 5 PSI	100 PSI
HP10000	Double Convoluted	HEAVY DUTY	5 PSI	100 PSI
HP10000J		HEAVY DUTY with JOUNCE BUMPER	0 PSI* / 5 PSI	100 PSI
HP10068	Large Double Convoluted	HEAVY DUTY	5 PSI	100 PSI
HP10438	Double Convoluted	EXTREME DUTY	5 PSI	100 PSI
HP10438J		EXTREME DUTY with JOUNCE BUMPER	0 PSI* / 5 PSI	100 PSI

* Springs with a jounce bumper can be run at zero PSI when vehicle is unloaded only

For safe and proper operation, never operate the vehicle over the maximum listed PSI in the air springs. Staying under the pressure limit will ensure maximum air spring life. **Failure in doing so may result in damage to your vehicle and/or a void warranty.**

! It is recommended to check the air pressure in your air springs daily for first couple of days to ensure a leak has not developed.

Air springs are designed to maintain the vehicle’s stock ride height with a load. Do not use the air springs as a means to lift vehicle with no load. This will result in a harsh ride.

SERVICING YOUR VEHICLE WITH AIR SUSPENSION

When lifting the vehicle with a floor jack or hoist on the frame, never allow the air spring to limit the travel of the axle. Try to always jack the vehicle on the axle. Suspending the axle with the air spring limiting the axle travel will damage the air spring and void the air spring warranty.

WARRANTY

See additional warranty included with this kit for details.