

# Installation Manual



## 10019 KIT

Universal Application\*

*Use this heavy duty air suspension kit to level your truck's stance and eliminate your vehicle's sag, sway and bottoming out while providing added support for an overall smooth & safe ride.*

\* See application guide for proper fitment.

L5685\_REV14\_04.26.2022



**WARNING:** This product can expose you to the chemical Hexavalent Chromate, which is known to the State of California to cause cancer and birth defects or other reproductive harm. *For more information go to [www.P65Warnings.ca.gov](http://www.P65Warnings.ca.gov)*

**IMPORTANT**

This air suspension kit will not increase the GVWR (*Gross Vehicle Weight Rating*), as the GVWR is determined by the vehicle manufacturer. **Do not exceed the maximum capacity listed by the vehicle manufacturer.**

***PLEASE NOTE***

***The air bag must have clearance between itself and the surrounding components to prevent any contact when bag is inflated or compressed. Trimming off excess bolt length is also required to ensure no contact with the air bag can be made once installed.***

*Safety Warnings!*

- ❗ Serious personal injury or death may result from an air spring failure or accident due to improper installation or air spring pressure operation or maintenance. Please read and abide the instructions, safety recommendations and maintenance suggestions throughout this manual.
- ❗ Inflating an unsecured air spring is dangerous. If it bursts, it could be hurled into the air with explosive force resulting in serious personal injury or death. Never inflate an air spring unless it is secured to the vehicle.
- ❗ Removing and replacing air springs can be dangerous. This is only a job for a qualified service professional. Never perform air spring service procedures without proper training, tools, and equipment.



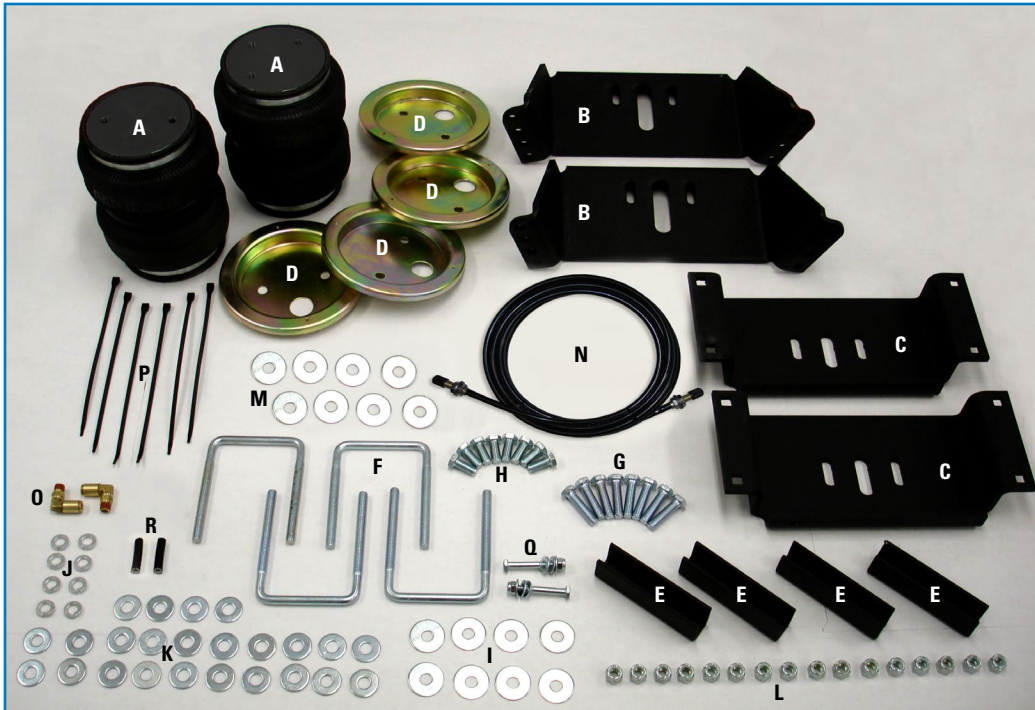

**KIT CONTENTS**

*Please make sure all the items shown in the kit layout are provided in your kit before starting the installation.*

KIT CONTENTS		QTY	PART #	REQUIRED TOOLS
<b>A</b>	Air Springs	2	HP10000	• Hoist or Floor Jack
<b>B</b>	Upper Brackets	2	HP0044	• Safety Stands
<b>C</b>	Lower Brackets	2	HP1577	• Safety Glasses
<b>D</b>	Roll Plates	4	HP10054	• Torque Wrench
<b>E</b>	Spacer Bracket	4	HP0028	• Standard Combination Wrenches
<b>F</b>	3/8" NC x 6 1/2" U-bolts	4	HP1018	• 7/32" Hex Allen Wrench
<b>G</b>	3/8" NC x 1 1/2" bolts	8	C18018	• 1-1/8" Wrench or Deep Socket
<b>H</b>	3/8" NF x 7/8" capscrews	8	HP1002	• Ratchet
<b>I</b>	3/8" Flat Washers Large O.D.	8	HP1013	• Metric & Standard Sockets
<b>J</b>	3/8" Lock Washer	8	C18007	• Hose Cutter (included) or Sharp Utility Knife
<b>K</b>	3/8" Flat Washer Small O.D.	24	C653	• Pipe Thread Sealant
<b>L</b>	3/8" Nylock Nuts	16	HP1000	• Hacksaw
<b>M</b>	3/8" Flat Washer 1/8" Thick	8	HP1135	• "C" Clamps
<b>N</b>	Air Line/Valve Assembly	1	HP1344	• Spray Bottle with Dish Soap/Water
<b>O</b>	Air Fitting	2	HP1100	• Air Compressor/Compressed Air Source (to test/fill air springs)
<b>P</b>	Tie Straps	6	C11618	
<b>Q</b>	1/4" Fastener, inner fender	2	HP1069 P02190 & HP1072	
<b>R</b>	Spacer Tube, inner fender	2	HP1070	

**BEFORE STARTING THE INSTALLATION:**

1. Ensure the application information is correct for the make, model and year of the vehicle you are installing the kit on.
2. Some vehicles are equipped with a rear wheel brake proportioning valve. Check with the manufacturer before installing the air spring kit, as it may affect braking performance.
3. Check the vehicle to see if it is equipped with a 5th Wheel Hitch. Some 5th wheel hitches require brackets to be mounted to the frame in the same locations as the air spring brackets (if this is the case, modifications of the 5th wheel hitch brackets may be required to mount this kit). Please contact customer service at 800.663.0096 if you have questions
4. Check the clearance between the outside of the frame and the inside of the tire, a minimum of 8" is required for air spring clearance.
5. It is recommended to use a good quality anti-seize on all fasteners. This will reduce the chance of corrosion on the fasteners and will help facilitate removal, if required at a later date.

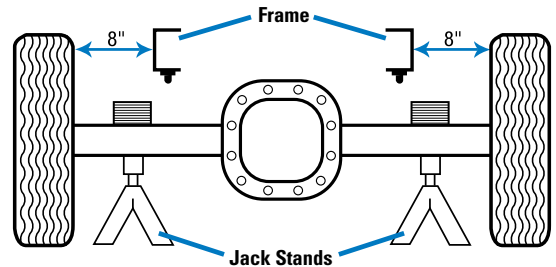

**PLEASE NOTE:**

***This kit contains push-to-connect fittings; using scissors or wire cutters to cut the nylon airline will distort the line and cause the connection to leak. THE AIRLINE MUST BE CUT OFF SQUARELY WITH THE NYLON HOSE CUTTER PROVIDED IN THIS KIT OR A SHARP UTILITY KNIFE.***

**1 MEASURE STOCK RIDE HEIGHT**

Park the vehicle on a level surface.

Remove any unnecessary weight from the vehicle to attain a Normal Ride Height. This is important for correct initial air spring set-up and adjustment.

Using a measuring tape, measure the distance between the center of the wheel hub and the bottom of the fender well (as shown in Figure 1) this will give you your ride height.

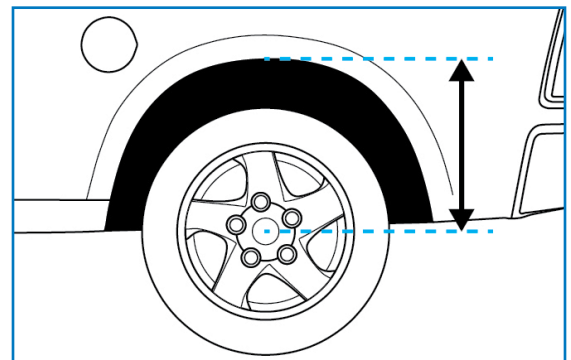

1

Note the ride height for all four corners.

**2 REMOVE REAR WHEELS**

Place wheel chocks in front of and behind both front wheels.

Raise the rear of the truck high enough to remove both wheels and attain a comfortable working height.

Place two jack stands under rear axle (shown in Figure 2). Lower the vehicle until the axle is supported by the jack stands.



2

Remove rear wheels.

### 3 LOWER BRACKET ASSEMBLY

Locate the end of the air spring with the 1/8" NPT air port (shown with an arrow in Figure 3A), place this side down with the air port away from you.

Place the roll plate over the end of the air spring (rounded end towards the air spring), aligning the two mounting holes.

Place the lower mounting bracket, over the roll plate and air spring aligning the two mounting holes, with the flange of the bracket towards you. (See Figure 3B).

Using the two 3/8" NF x 7/8" capscrews, flat and lock washers, loosely fasten the assembly together.

Do not tighten the capscrews fully until final adjustment is performed in Step 7.

**Repeat on other side.**

### 4 1994 and newer Dodge 4X4 trucks only: Removal of the rear wheelhouse liner is required to access the frame.

Remove the 4 plastic rivets (shown in Figure 4) by pushing the inner pin through from the outside. Then remove the 3 capscrews securing the liner to the box.

Rotate the liner towards the rear of the vehicle to remove.

Save the 4 plastic rivets for reassembly.

### 5 Place the lower air spring assembly on top of the leaf spring with the flanged side of the lower bracket facing outward.

Using Figure 5 as reference, center the lower bracket above the center of the axle tube.

Place the upper bracket on top of the air spring assembly.

Check the vehicle frame where the upper air spring bracket flanges meet, some trucks will have an impression in the frame, these vehicles require the spacers provided be installed as shims to compensate.

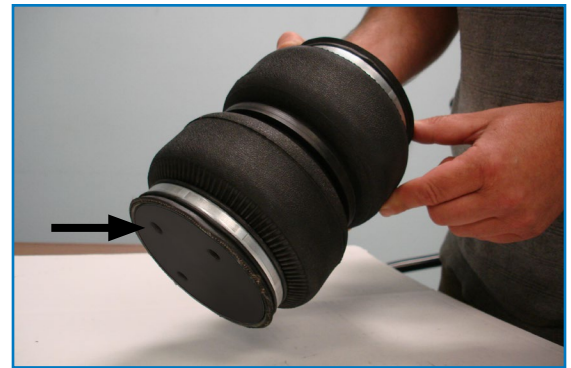

3A



3B

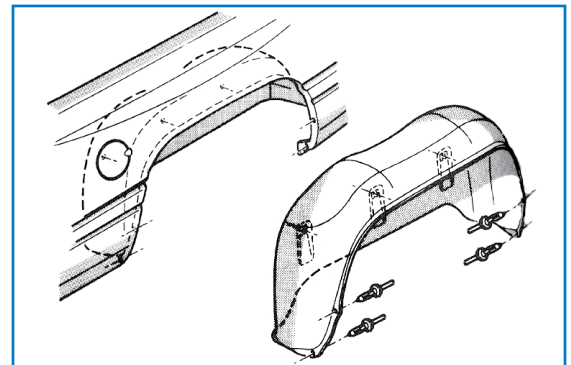

4

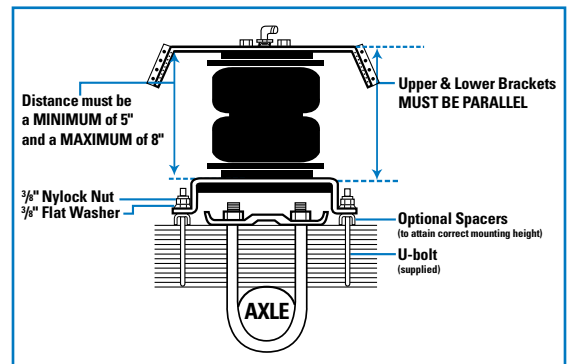

5

- 6 Using 2 "C" clamps, clamp the upper bracket to the frame. If necessary, install the frame to bracket spacers. Ensure the center of the brackets are centered above the axle for correct alignment (as shown in Figure 5 on previous page).

Ensure the minimum and maximum distances (from Figure 5) are achieved and the brackets are parallel to each other.

4 spacer brackets are provided to attain correct mounting height if necessary, install them between the leaf spring and the lower bracket.

**NOTE: Remove the lower air spring assembly when drilling the holes in the frame to avoid metal chips falling into the lower roll plate cavity. Install the 90° air supply fitting into the top of the air spring using thread sealant.**

- 7 Once the correct position of the upper bracket is confirmed choose the 2 best mounting holes in each flange, top and bottom holes preferred.

Check the inside of the frame for obstructions like electrical harnesses before drilling.

Using the bracket as a template drill 4 - 3/8" mounting holes (see Figure 7).

Fasten the bracket using the 3/8" x 11/2" fasteners, small O.D. washers under the head of the fastener and the large O.D. washers on the inside of the frame, the nylock nuts and any spacers required between the upper bracket and the frame.

Torque the fasteners to 40 ft-lbs.

- 8 Reinstall the lower air spring assembly.

Using the 3/8" x 7/8" capscrews, flat and lock washers loosely fasten the top of the air spring to the upper bracket.

Install the "U" bolts around the leaf spring and through the two holes in the lower bracket. If the vehicle has overload springs, install "U" bolts as shown in Figure 8A. Otherwise, install "U" bolts around the entire leaf pack.

Adjust the air spring on their brackets to achieve correct alignment (see Figure 8B). Once the correct alignment is achieved, tighten the upper and lower brackets to the air spring. Torque to 20 ft-lbs.



6

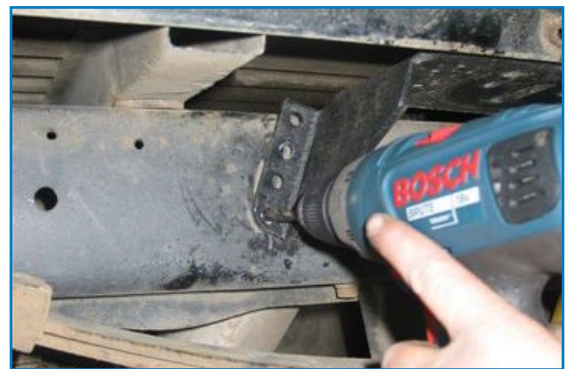

7



8A

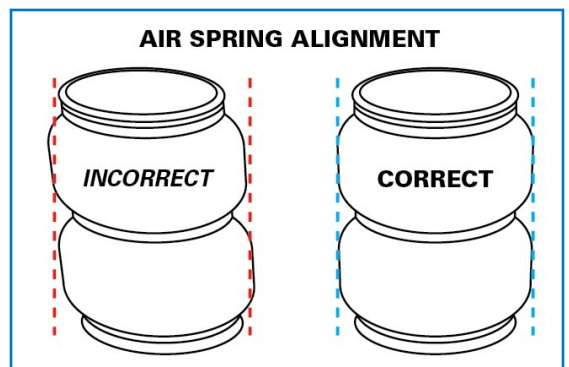

8B

- 9 Tighten the front and rear “U” bolts around the leaf spring pack. Use the nylock nuts and small O.D. flat washers, torque to 16 ft-lbs.

Cut off the threaded portion of the “U” bolt above the nylock nut.

**Repeat Steps 4 to 9 on the other side of the vehicle.**

Reinstall the inner fender liner if removed. A spacer and 1/4” fastener is provided to replace the center capscrew and space the liner away from the air spring.



9

## 10 INSTALL AIR LINE

**PLEASE NOTE: This kit contains push-to-connect fittings, using scissors or wire cutters to cut the nylon airline will distort the line and cause the connection to leak. THE AIRLINE MUST BE CUT OFF SQUARELY WITH THE NYLON HOSE CUTTER PROVIDED IN THIS KIT OR A SHARP UTILITY KNIFE**

Provided in air spring kit are two fill valves. The most common place to install is in place of license plate fasteners. Alternatively, two 5/16” holes can be drilled in a convenient location.

Cut air line assembly into two equal lengths with hose cutter.

Install one air line, route the nylon air line to an air spring fitting and cut the hose. Moisten the end of the air line prior to inserting it into the fitting and push it in until it stops. Repeat with the other fill valve.

Secure airlines using the tie-straps, away from moving items and heat sources.

Place a 5/16” nut on the air valve. Leave enough of the inflation valve in front of the nut to extend through the hole, install a flat washer, and 5/16” nut and cap (reference Figure 10 for assembly). There should be enough valve exposed after installation—approximately 1/2”—to easily apply a pressure gauge or an air chuck.

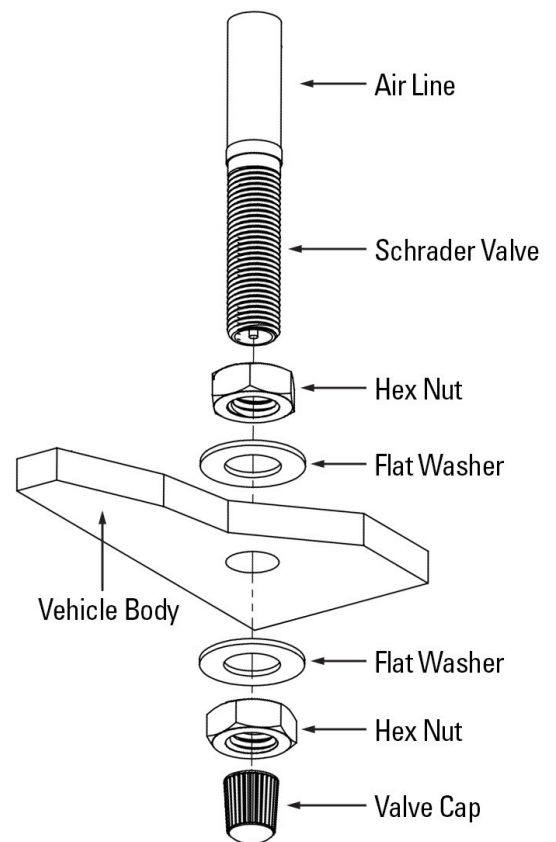

10

**If an in-cab inflation kit is being installed, follow the instructions provided with that kit now.**

## 11 CHECK SYSTEM FOR LEAKS

Inflate both air springs to 90 psi and then use a mixture of dish soap and water on all air line connections to detect any air leaks. Large, expanding bubbles indicate a leak (as shown in Figure 11). Repair as necessary and retest.

Inflate air springs to a predetermined value and on following day recheck pressure. If one or both of air springs have lost pressure, an air leak is present. Leak must be repaired, and then retested until no leaks exist.

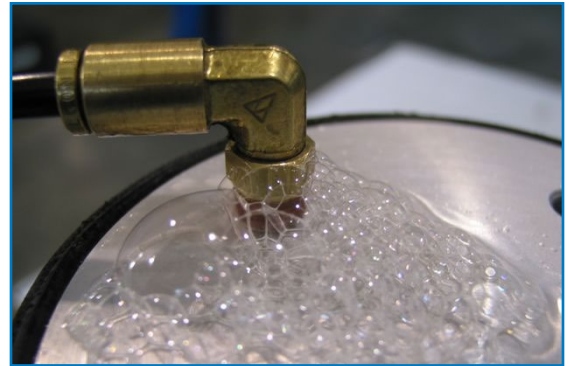

11

## AFTER COMPLETING THE INSTALLATION

### PLEASE REMEMBER:

Install wheels and torque fasteners to manufacturer's specifications.

Re-torque all fasteners after first 500 miles of driving.

For safe and proper operation, never operate the vehicle under minimum of 10 psi or over maximum of 100 psi in air springs. Staying within pressure limit will ensure maximum air spring life. Failure in doing so may result in a void warranty (see **Note** below).

**NOTE: Do not exceed maximum vehicle payload. Failure to do so may result in failure of the air suspension kit and/or damage to your vehicle.**



***Thank you again, and congratulations on the installation of the air suspension kit.***

## **OPTIONAL ACCESSORIES**

Optional dual needle air gauges are available to monitor pressure in each spring from vehicle cab, as well as a full line of air compressors, air tanks, and solenoids built to work with and control your air spring system.

## **OPERATING YOUR VEHICLE WITH AIR SUSPENSION**

Air springs have minimum and maximum pressure requirements. Never operate your vehicle with less than 10 psi in air spring and never inflate air springs over 100 psi. Damage to air springs will result.

Check air pressure in air springs daily for first couple of days to ensure a leak has not developed. Air springs are designed to maintain the vehicles stock ride height with a load. Do not use the air springs as a means to lift vehicle with no load. This will result in a harsh ride.

## **SERVICING YOUR VEHICLE WITH AIR SUSPENSION**

When lifting the vehicle with a floor jack or hoist on the frame, never allow the air spring to limit the travel of the axle. Try to always jack the vehicle on the axle. Suspending the axle with the air spring limiting the axle travel will damage the air spring and void the air spring warranty.

## **WARRANTY**

To be eligible for warranty, the owner must submit their warranty card or register online within 30 days of the purchase date.

***NOTE: The owner's warranty will be void if air springs are run with less than the minimum of 10 psi.***

.....