

# INSTALL INSTRUCTIONS FOR 82-1000

## PART#: 82-1000



PRINT

### MAP SPACER

#### Vehicle Application

Year: 2017, 2018

Make: Chevrolet/GMC

Model: 2500/3500

Engine: 6.6L Duramax

Thank you for purchasing your new S&B Filters Map Spacer. If at any time you need additional assistance with installation or have any other questions or comments, feel free to call our customer support team at 909-947-0015.

### Tools Required

- 5mm Allen Wrench Socket
- 10mm Wrench/Socket
- Torque Wrench

Approx. Install Time: 15 min

### CARB Status

Carb Status: Pending

Product will be submitted to Air Resources Board for approval shortly.

Not legal for use in CA or other states adopting CA emissions standards.

# PARTS LIST

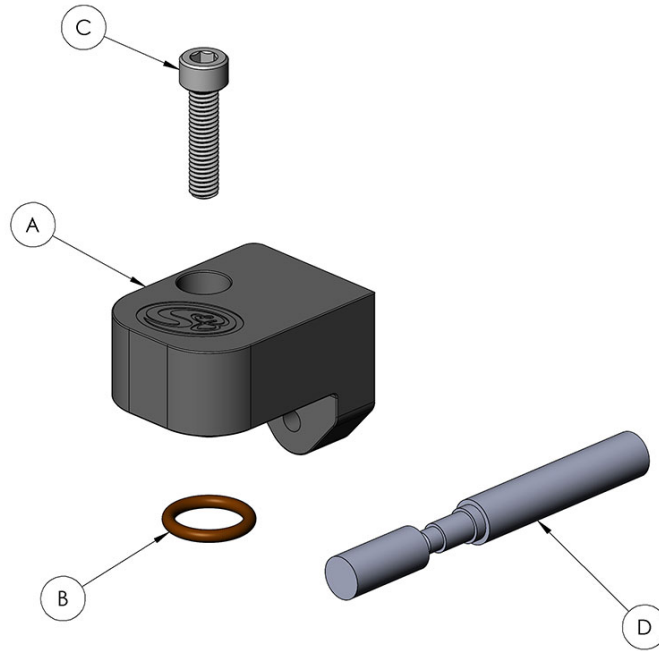

ITEM NO.	QTY.	PART NUMBER	DESCRIPTION
A	1	AI2247-00	Map Spacer, Black Anodize
B	1	AI2248-00	O-Ring, Viton
C	1	90128A265	SHCS, M6 x 1 x 25mm Long, Class 12.9, Zinc Plated
D	1	AI1595-00	Threadlocker

# INSTALLATION STEPS

## Before you Start

- Please read the entire product guide before proceeding.
- Ensure all components listed above are present.
- If you are missing any of the components, call the S&B Customer Support Team at (909) 947-0015.
- Do not work on your vehicle while the engine is hot.
- Make sure the engine is turned off and the vehicle is in Park and the Parking Brake is set.

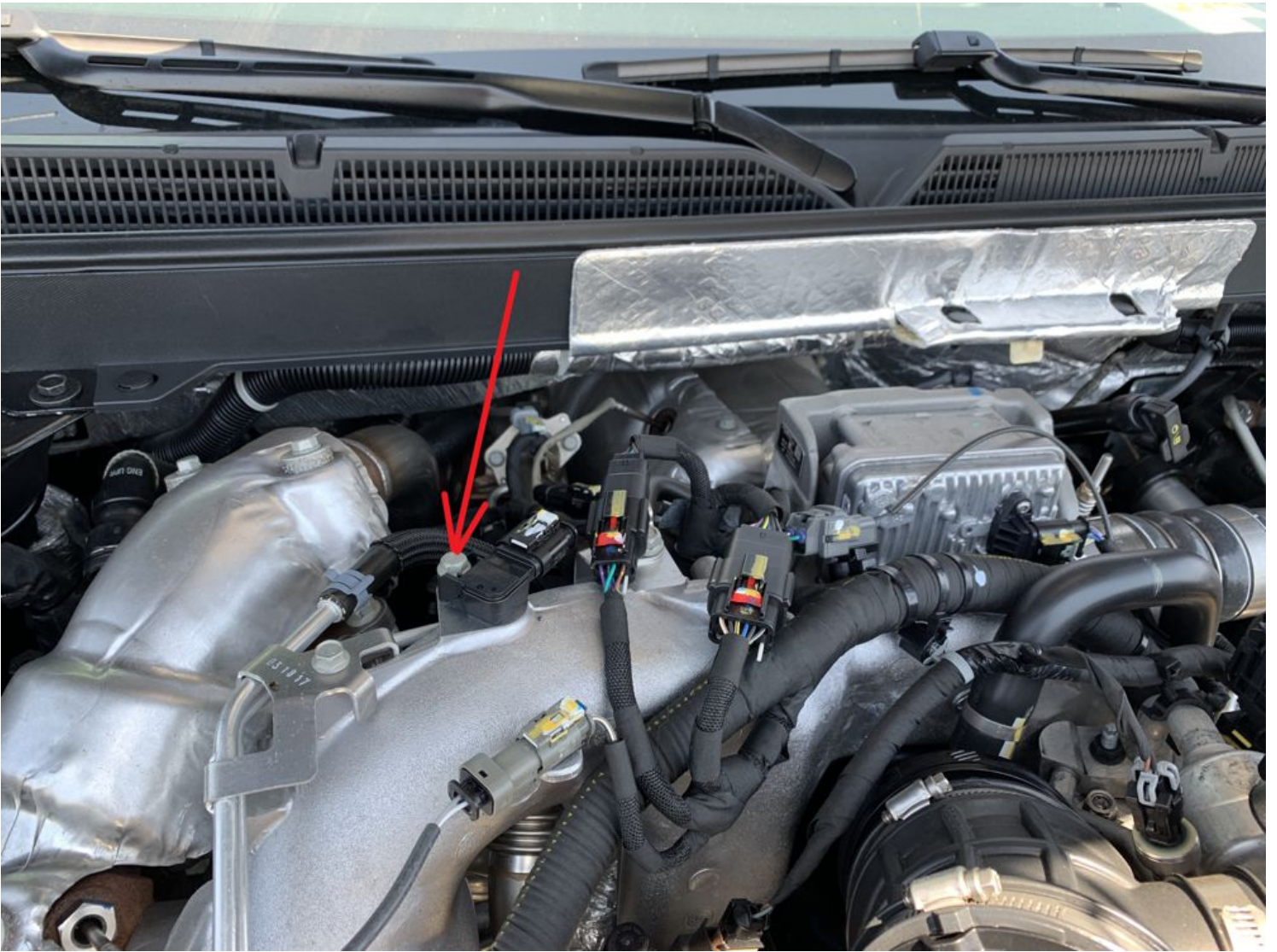

## **STEP 1**

Make sure the engine is off, cooled down, and the vehicle is safely parked with the parking brake set. Locate the MAP Sensor and the M6 Hex Head Flange Screw holding the MAP Sensor in place.



## **STEP 2**

Remove the M6 Hex Head Flange Screw and keep it to use in Step 4. Do not disconnect the harness from the MAP Sensor.

Tools Needed: 10mm Socket Wrench





### **STEP 3**

Carefully remove the MAP Sensor from the Intake Manifold. A back and forth twisting helps to make removal easier.

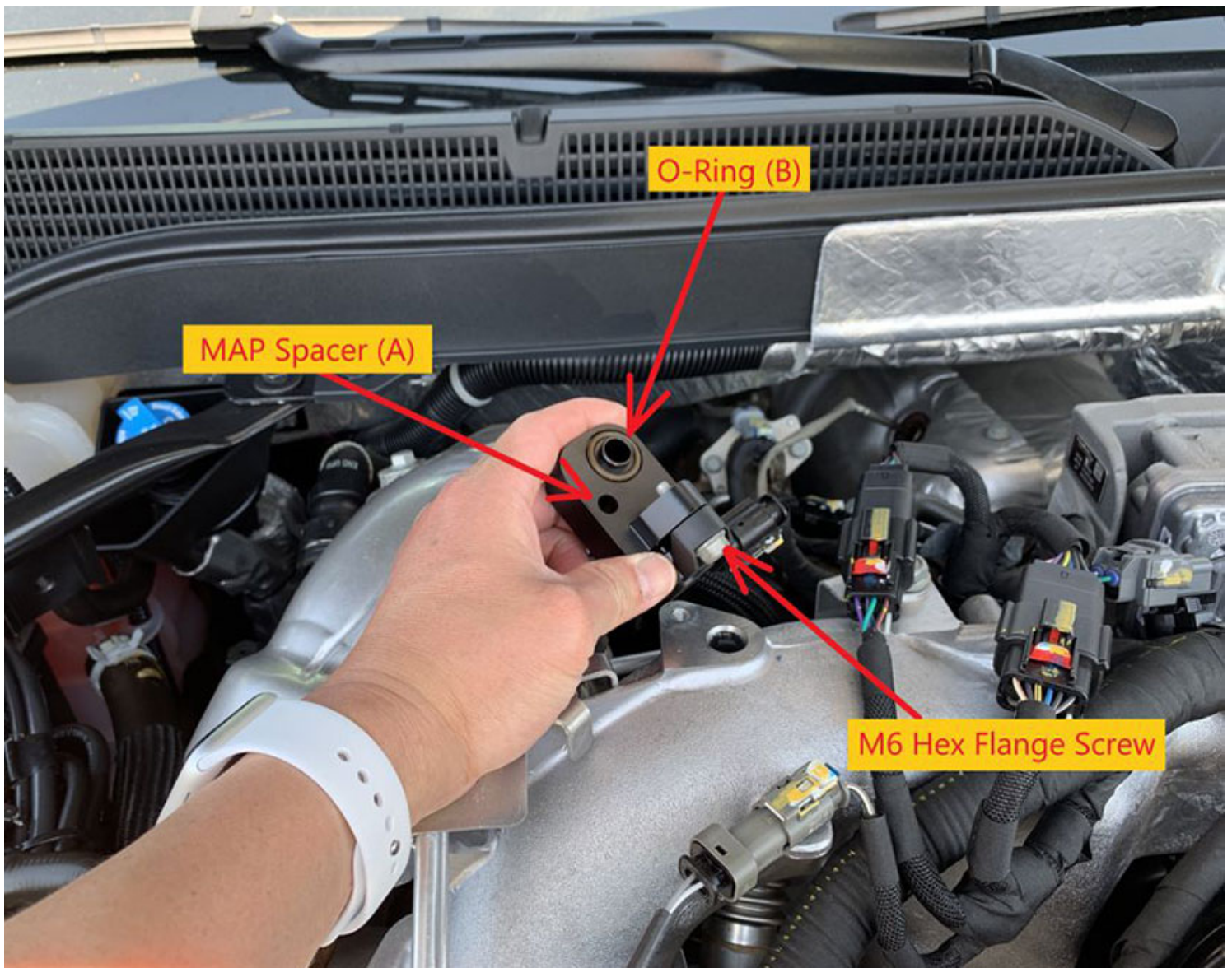

## STEP 4

Carefully insert the MAP Sensor into the MAP Spacer (A) and secure it with the M6 Hex Head Flange Screw as shown. Do not use any Threadlocker on this screw and hand tighten only. Install the O-Ring (B) into the Spacer groove. Carefully stretch the O-Ring over the lip to fully seat into the groove. Once fully seated, the O-Ring will stay in the groove as you turn the Spacer over for installation into the Intake Manifold.



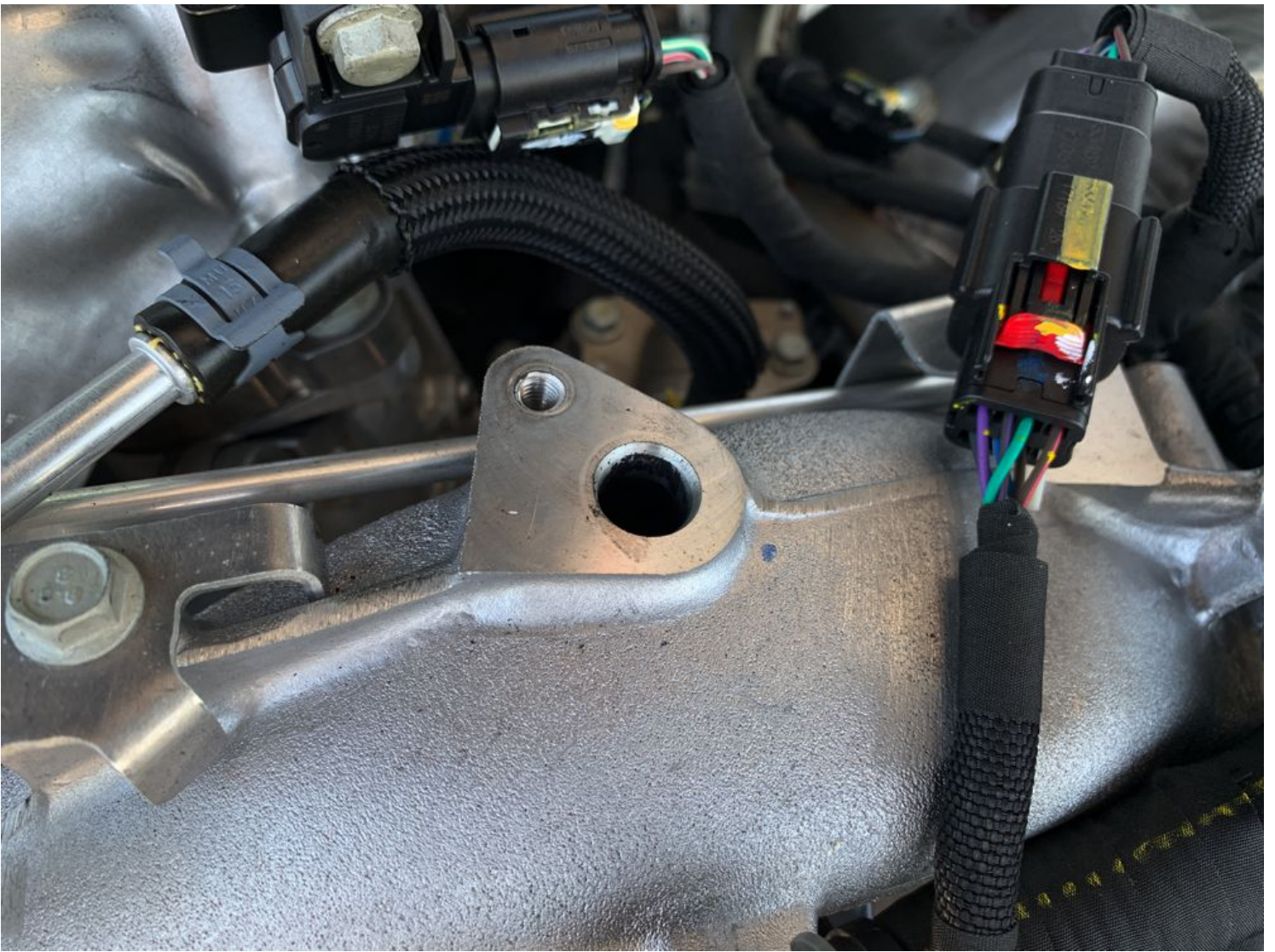

## **STEP 5**

Make sure the mounting face and tapped hole of the Intake Manifold are clean.

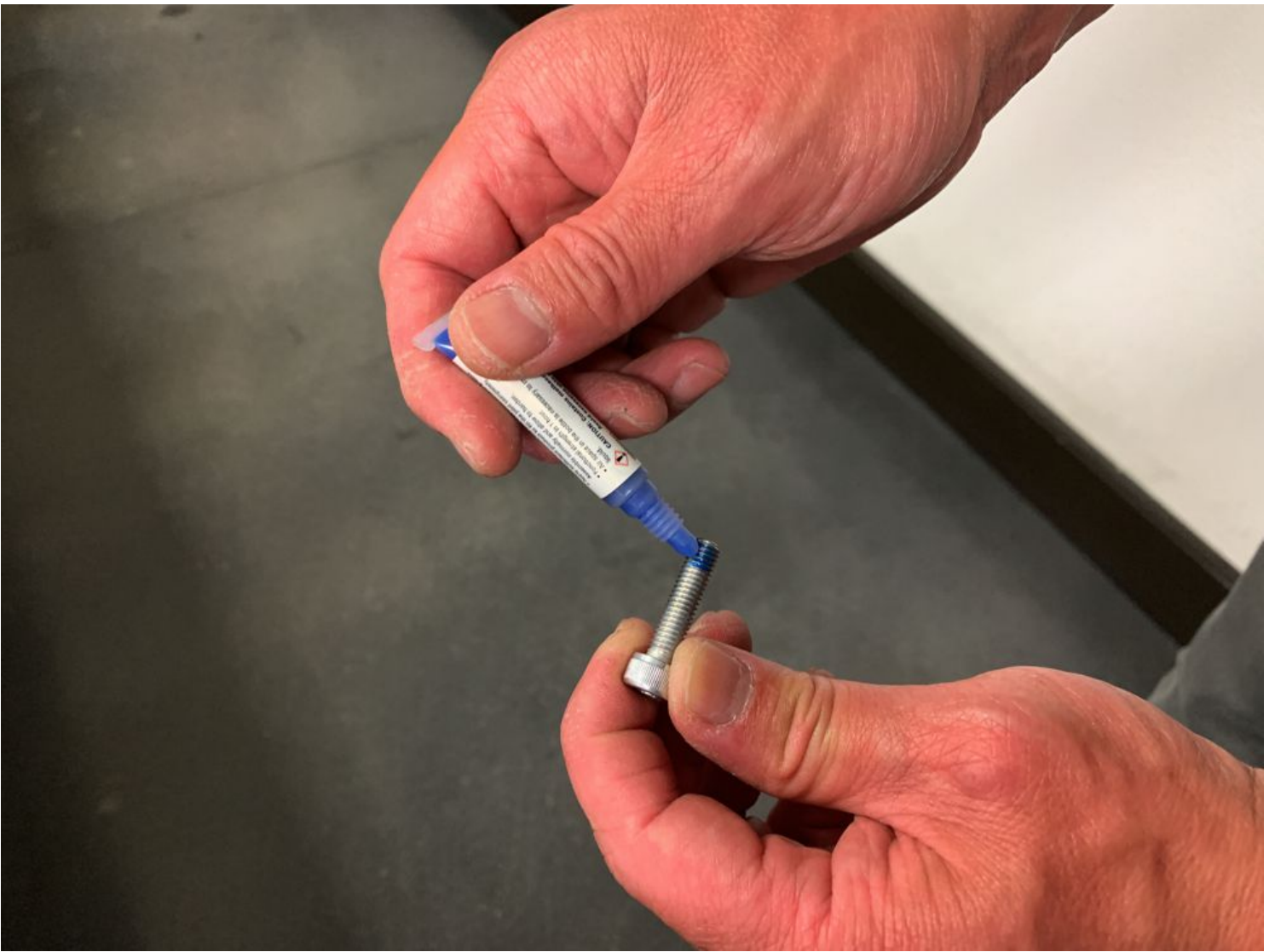

## **STEP 6**

Apply a small drop of Threadlocker (D) onto the end of the M6 Socket Head Cap Screw (C).





## **STEP 7**

Install the MAP Spacer into the Intake Manifold as shown. Make sure the O-Ring (B) does not accidentally fall out of the groove. When the O-Ring is fully seated in the groove, it will not fall out. Use the M6 SHCS (C) to secure the MAP Spacer to the Manifold. Torque the M6 SHCS to 60 in-lbs. Torque the M6 Hex Flange Screw (from Step 4) to 60 in-lbs.

Tools Needed: 10mm Socket, 5mm Allen Wrench Socket, Torque Wrench.

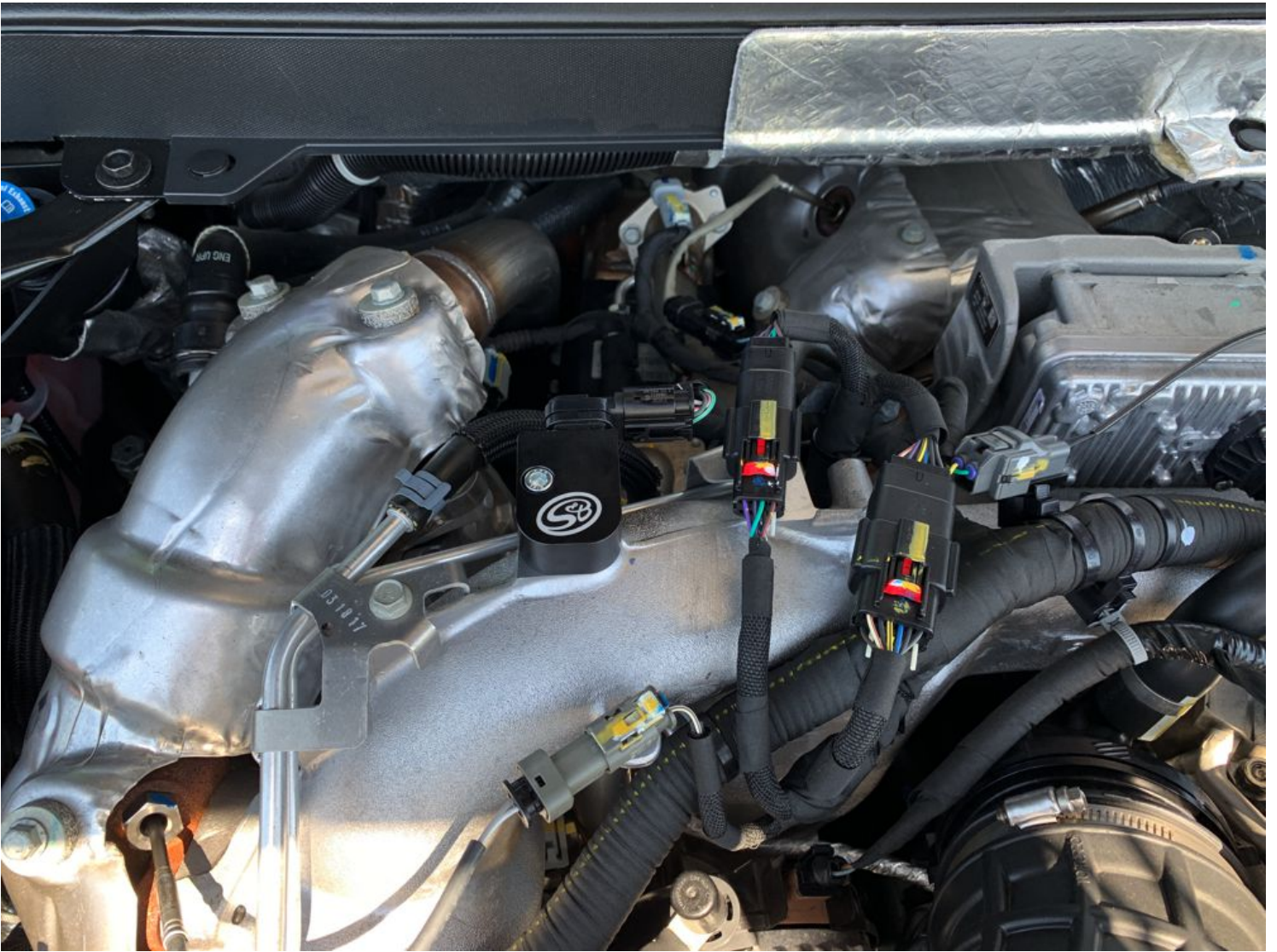

## **STEP 8**

Finished installation should look like this as shown. Make sure the MAP Sensor and Harness are free from rubbing other components that may cause any wear or damage.





