

SSV KIT - Engine Pre-filter S&B Particle Separator

Part number (SKU) : 715004422

Product: **Side-by-side**
 Project no: **487802501**
 Instruction Sheet P/N: **487802501**
 Revision no:
 Revision date:
 Item covered: **Engine Pre-filter S&B Particle Separator**

The following symbols may be used in this document:

WARNING

Indicates a hazardous situation which, if not avoided, could result in death or serious injury.

CAUTION: Indicates a hazard situation which, if not avoided, could result in minor or moderate injury.

NOTICE Indicates an instruction which, if not followed, could severely damage vehicle components or other property.

WARNING

- This kit is designed for specific applicable models only (authorized BRP dealers will confirm model(s)). It is not recommended for units other than the one (those) for which it was sold.
- If the installation of the kit requires a template, ensure template is to scale.
- Should removal of a locking device (e.g. lock tabs, self-locking fasteners, etc.) be required when undergoing disassembly/ assembly, always replace with a new one.
- Torque wrench tightening specifications must strictly be adhered to.

NOTE: USE TIGHTENING TORQUES IN THE FOLLOWING TABLE IF NOT OTHERWISE SPECIFIED.

	GRADE			
	5.8	8.8	10.9	12.9
M4	1.8 ± 0.2 N•m (16 ± 2 lbf•in)	2.8 ± 0.2 N•m (25 ± 2 lbf•in)	3.8 ± 0.2 N•m (34 ± 2 lbf•in)	4.5 ± 0.5 N•m (40 ± 4 lbf•in)
M5	3.3 ± 0.2 N•m (29 ± 2 lbf•in)	5 ± 0.5 N•m (44 ± 4 lbf•in)	7.8 ± 0.7 N•m (69 ± 6 lbf•in)	9 ± 1 N•m (80 ± 9 lbf•in)
M6	7.5 ± 1 N•m (66 ± 9 lbf•in)	10 ± 2 N•m (89 ± 18 lbf•in)	12.8 ± 2.2 N•m (113 ± 19 lbf•in)	16 ± 2 N•m (142 ± 18 lbf•in)

M8	15.3 ± 1.7 N•m (135 ± 15 lbf•in)	24.5 ± 3.5 N•m (18 ± 3 lbf•ft)	31.5 ± 3.5 N•m (23 ± 3 lbf•ft)	40 ± 5 N•m (30 ± 4 lbf•ft)
M10	29 ± 3 N•m (21 ± 2 lbf•ft)	48 ± 6 N•m (35 ± 4 lbf•ft)	61 ± 9 N•m (45 ± 7 lbf•ft)	73 ± 7 N•m (54 ± 5 lbf•ft)
M12	52 ± 6 N•m (38 ± 4 lbf•ft)	85 ± 10 N•m (63 ± 7 lbf•ft)	105 ± 15 N•m (77 ± 11 lbf•ft)	128 ± 17 N•m (94 ± 13 lbf•ft)
M14	85 ± 10 N•m (63 ± 7 lbf•ft)	135 ± 15 N•m (100 ± 11 lbf•ft)	170 ± 20 N•m (125 ± 15 lbf•ft)	200 ± 25 N•m (148 ± 18 lbf•ft)
M16	126 ± 14 N•m (93 ± 10 lbf•ft)	205 ± 25 N•m (151 ± 18 lbf•ft)	255 ± 30 N•m (188 ± 22 lbf•ft)	305 ± 35 N•m (225 ± 26 lbf•ft)
M18	170 ± 20 N•m (125 ± 15 lbf•ft)	273 ± 32 N•m (201 ± 24 lbf•ft)	330 ± 25 N•m (243 ± 18 lbf•ft)	413 ± 47 N•m (305 ± 35 lbf•ft)

NOTE: For Stainless Steel Fasteners, Use the Torque Numbers listed for 5.8 Grade.

NOTE: The illustrations in this document show typical construction of the different assemblies and may not reproduce the full detail or exact shape of the parts; however, they represent parts that have the same or similar function.

Installation time is approximately 2.0 hours.

PARTS TO BE INSTALLED

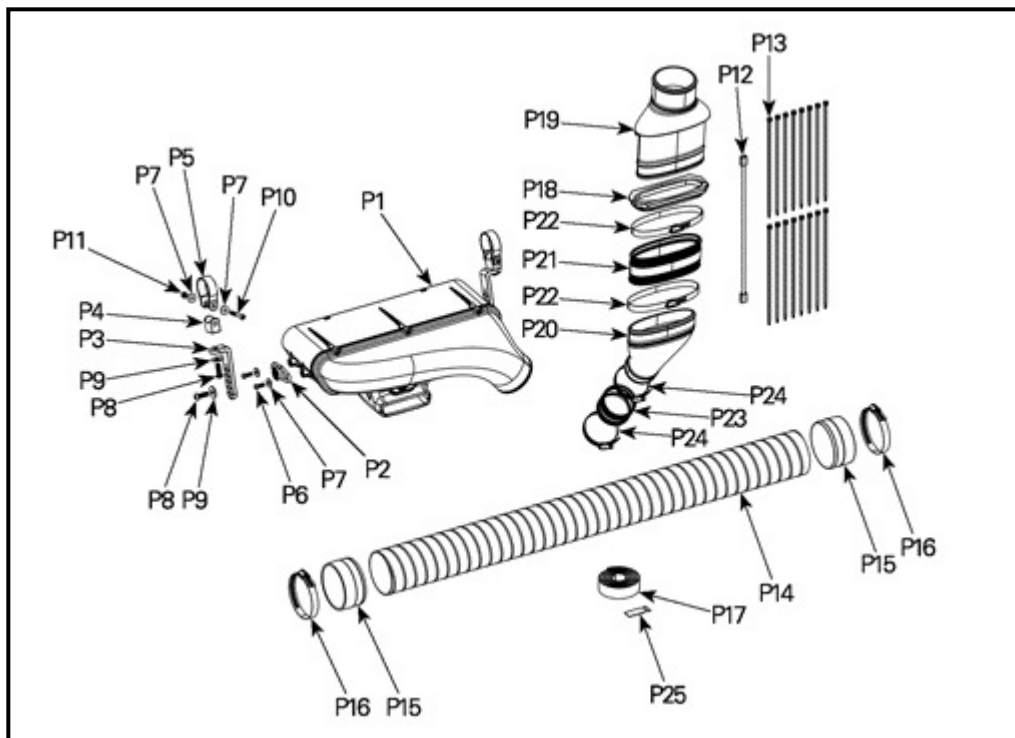

ITEM	DESCRIPTION	QTY
P1	Particle Separator	1
P2	Clamp Adapter	2

ITEM	DESCRIPTION	QTY
P3	Clamp L-Bracket	2
P4	Clamp Pivot	2
P5	Clamp Strap (4.7 cm (1.85 in))	2
P6	M6 X 18 Button Socket Cap Screw	4
P7	M6 Fender Washer	8
P8	M8 X 25 Button Socket Cap Screw	4
P9	M8 Fender Washer	4
P10	M6 X 50 Button Socket Cap Screw	2
P11	M6 Nylon Locknut	2
P12	Universal Wire Harness	1
P13	Cable Tie	16
P14	Flexible Duct	1
P15	Flexible Duct End Cuff	2
P16	Hose Clamp, #56	2
P17	Velcro Strap	1
P18	Panel Snap-in Grommet	1
P19	Upper Tube	1
P20	Lower Tube	1
P21	Ellipse Coupler	1
P22	Hose Clamp, #72	2
P23	Straight Coupler	1
P24	Hose Clamp, #40	2
P25	Threadlocker	1

INSTALLATION

Vehicle preparation

Familiarize yourself with all the pieces of this kit.

Locate particle separator [P1].

NOTE: The wire behind the particle separator must come out the same side as the air inlet.

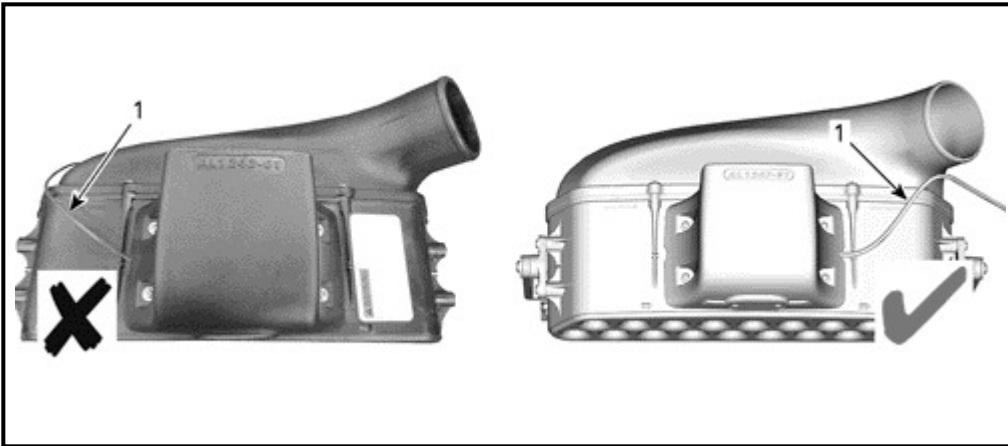

1. Wire

Drill one (1) 11 mm (7/16 in) hole onto the top of the cargo box using template.

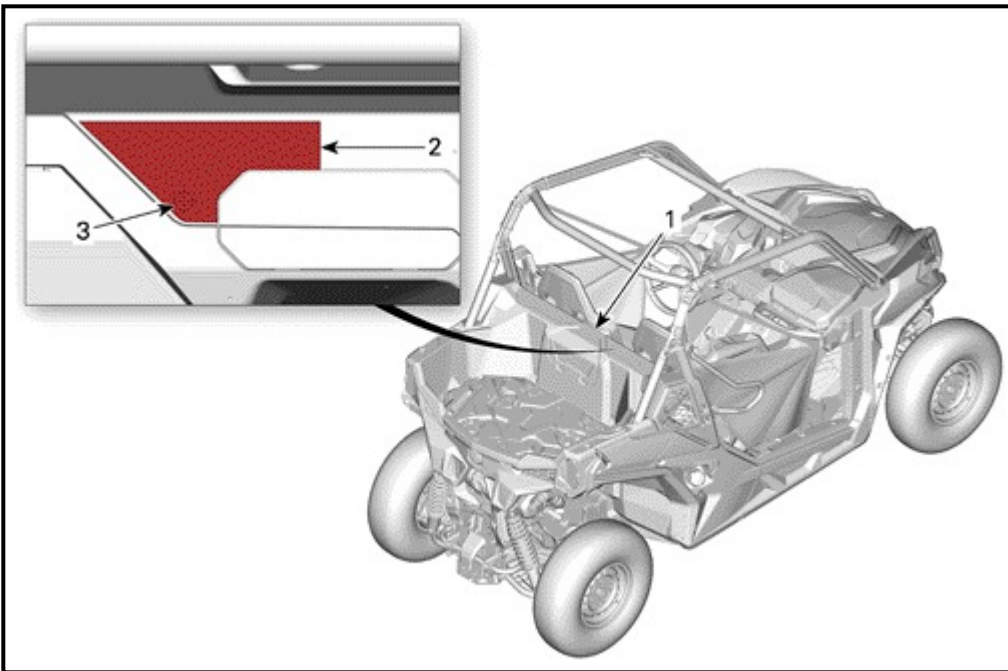

1. Cargo box
2. Template
3. Drill 11 mm (7/16 in) hole

Remove air filter access door by unscrewing the quarter turn fasteners

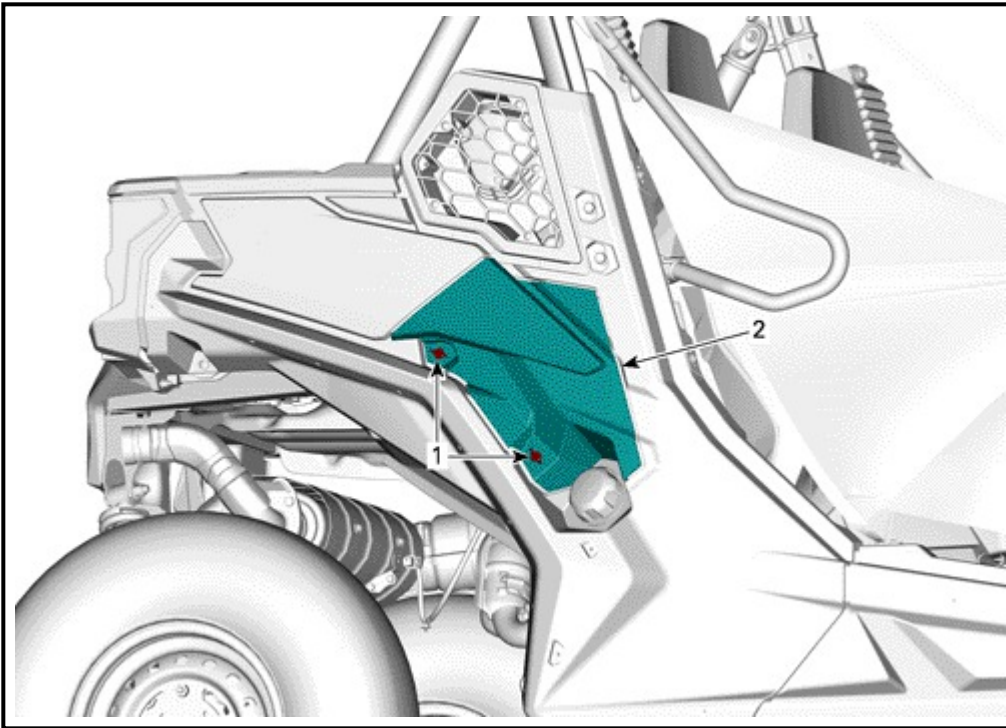

RH SIDE OF VEHICLE, UNDER CARGO BOX

1. Quarter turn fasteners
2. Air filter access door

Remove and keep the air intake grid by removing the five (5) K60 X 25 hexagonal screws.

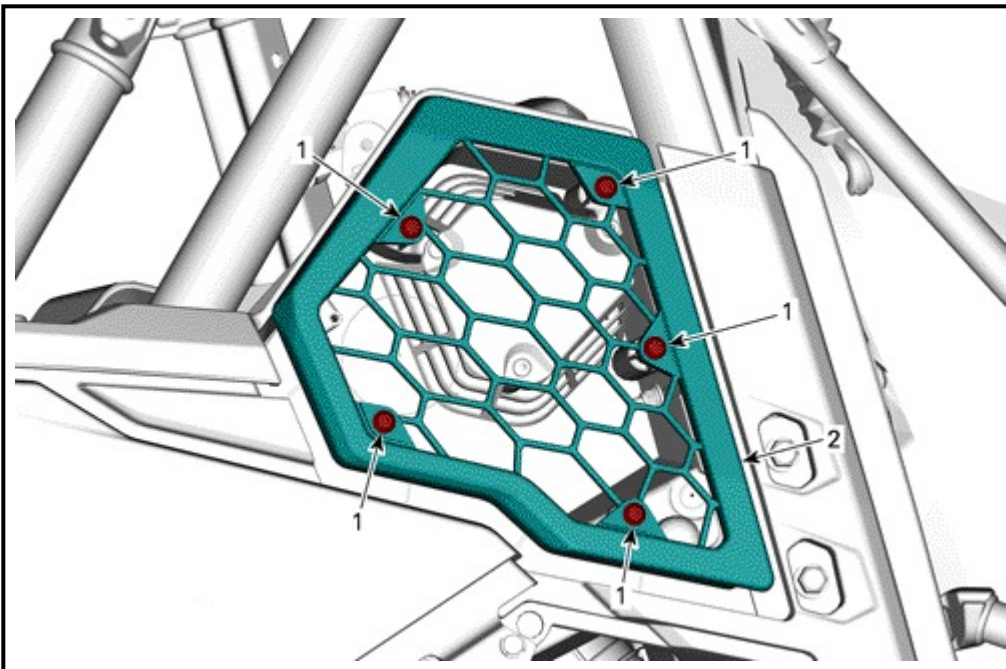

RH SIDE OF THE VEHICLE

1. K60 X 25 hexagonal screws
2. Air intake grid

Remove and keep the baffle of the air intake by removing the three (3) K50 X 16 Torx screws.

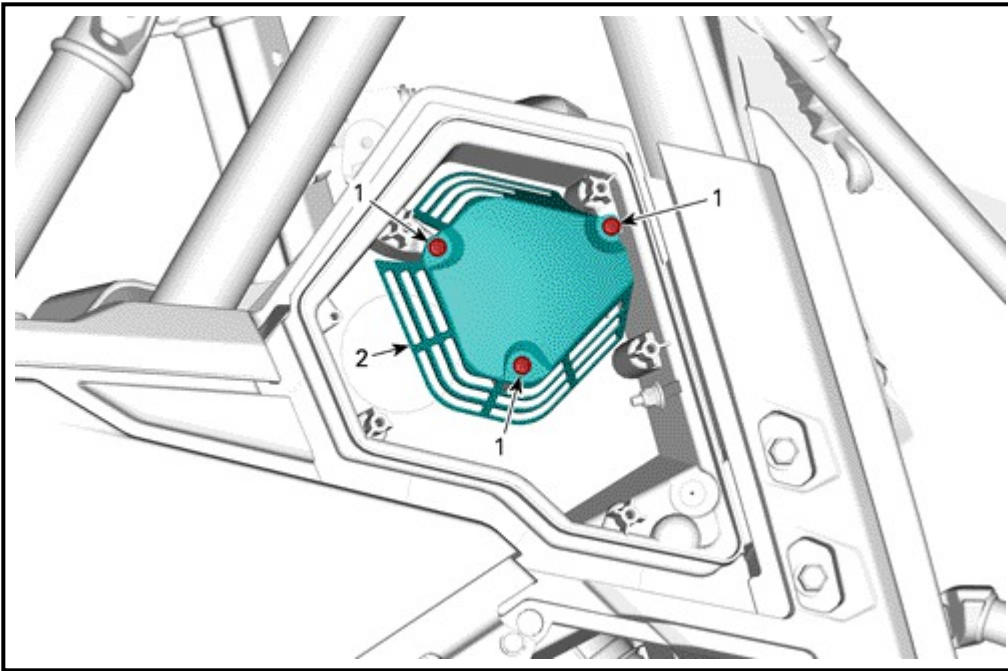

RH SIDE OF THE VEHICLE

- 1. K50 X 16 Torx screws*
- 2. Baffle*

Loosen the hose clamp for the air intake tube at the air intake box.

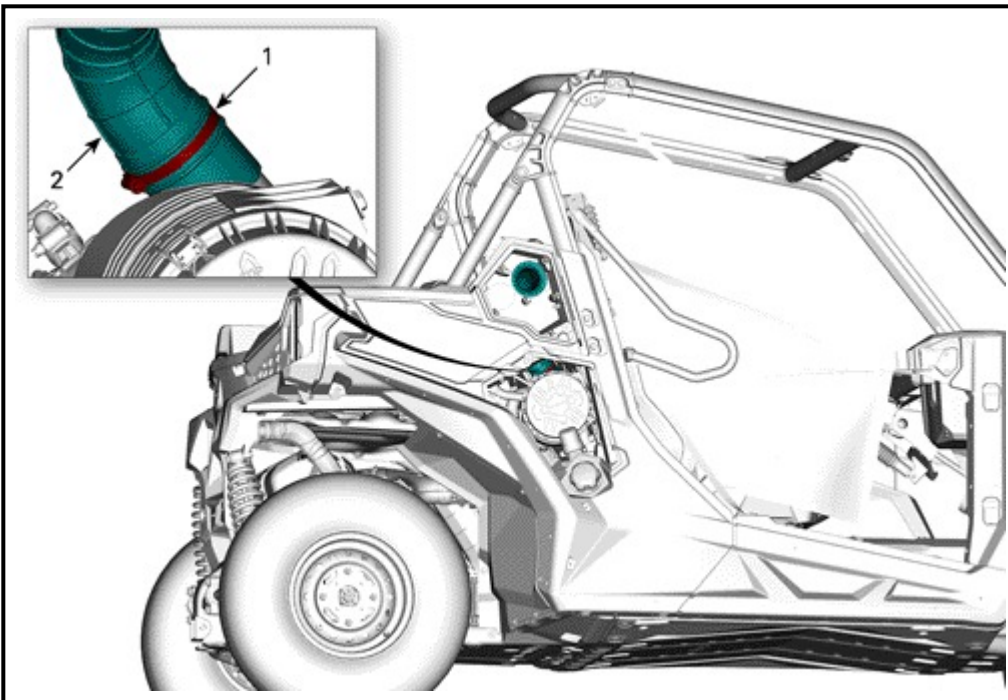

- 1. Hose clamp*
- 2. Air intake tube*

Remove the air intake tube by pushing on the top of the tube.

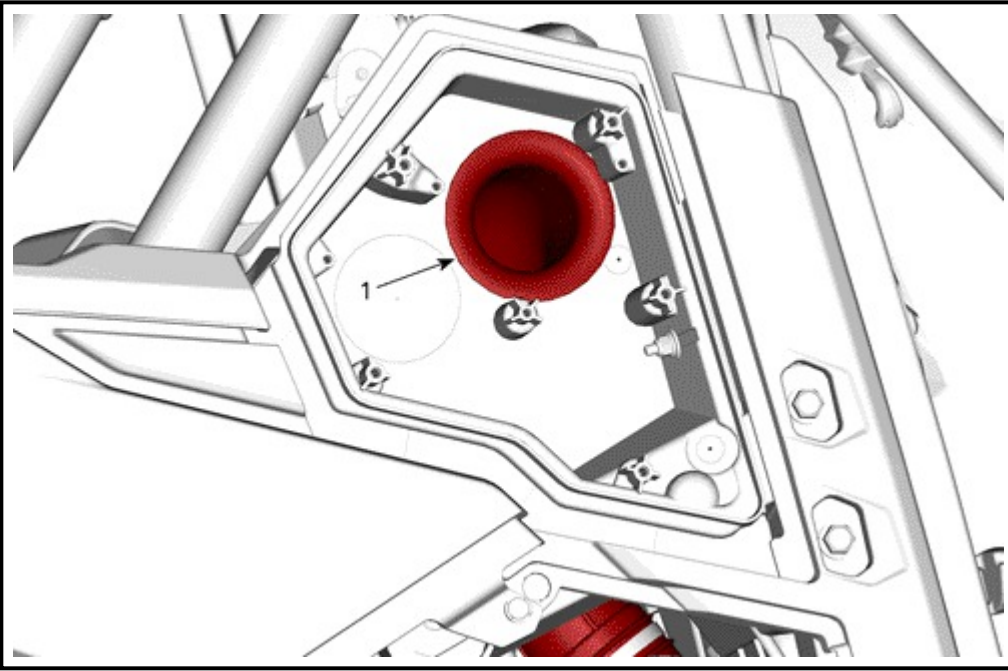

1. Air intake tube

Remove the access cover on top of the cargo box.

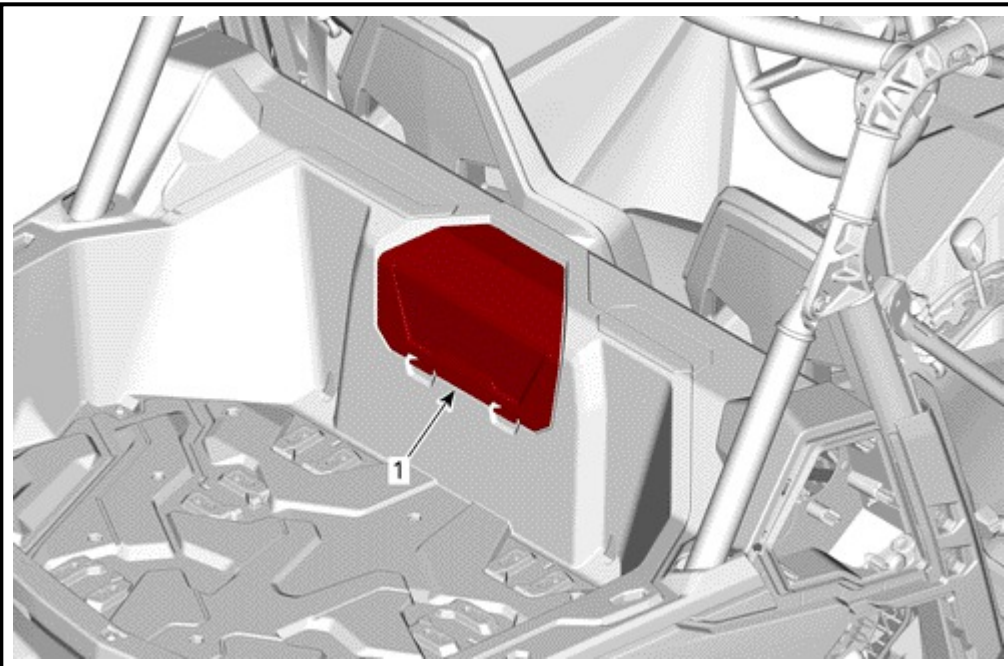

1. Access cover

Remove the air intake cover on top of the cargo box toward the passenger side.

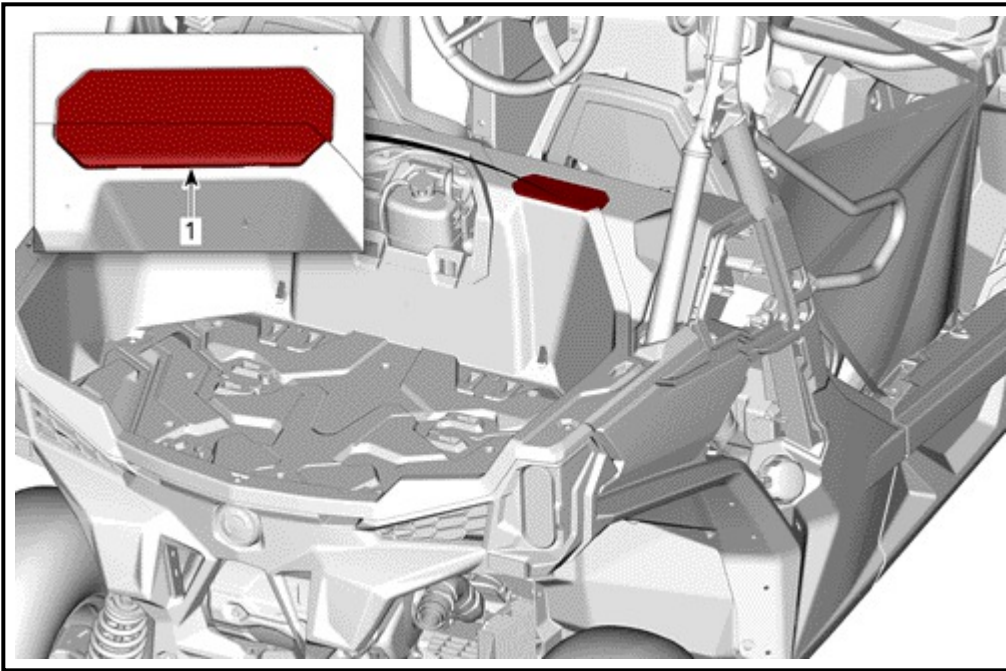

1. Air intake cover

Parts Installation

Installation of the lower and the upper tube

Assemble lower tube [P20] with coupler [P23], two hose clamps #40 [P24], ellipse coupler [P21] and two (2) hose clamps #72 [P22]. Position the hose clamps in a way that it would be easily accessible to tighten when installed onto air intake box. Tighten only the hose clamps directly connected to the lower intake tube.

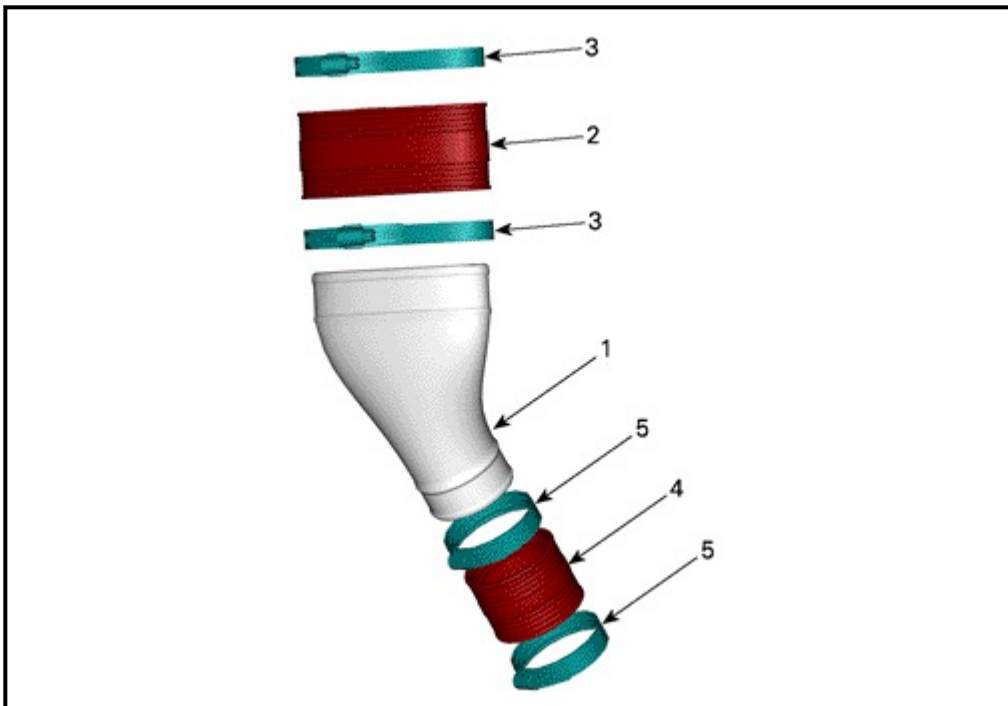

1. Lower tube [P20]
2. Straight coupler [P23]
3. Hose clamps #40 [P24]
4. Ellipse coupler [P21]
5. Hose clamps #72 [P22]

Install the lower tube [P20] with couplers onto the air intake box. Do not tighten any hose clamps yet.

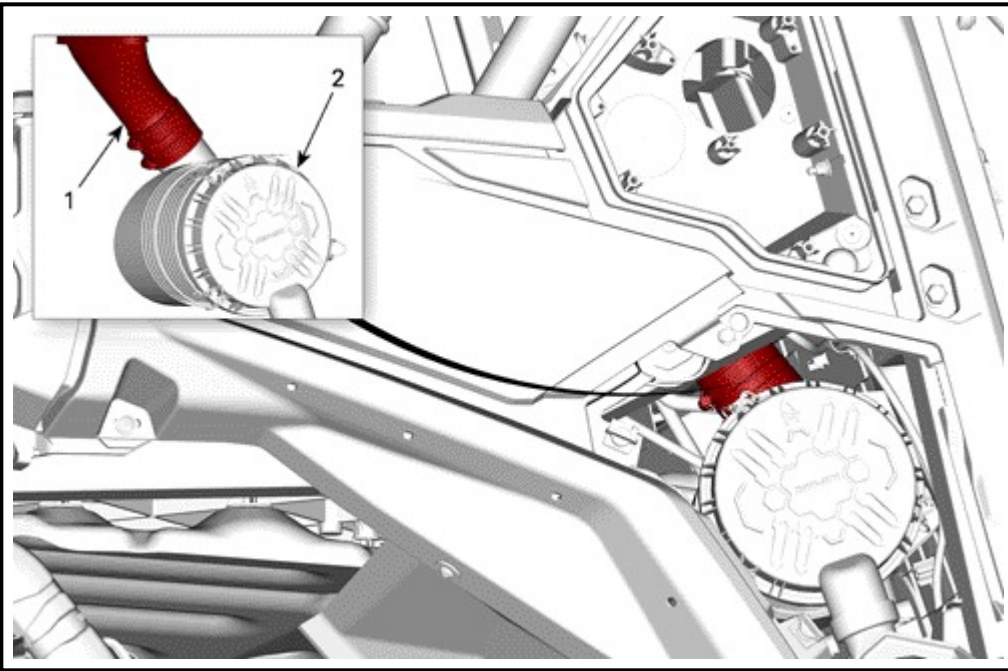

1. Assembly of the lower tube [P20]
2. Air intake box

Install panel snap-in grommet [P18] into the opening left by the air intake cover on top of the bed toward the passenger side of the vehicle. Make sure the panel snap-in grommet [P18] sits evenly.

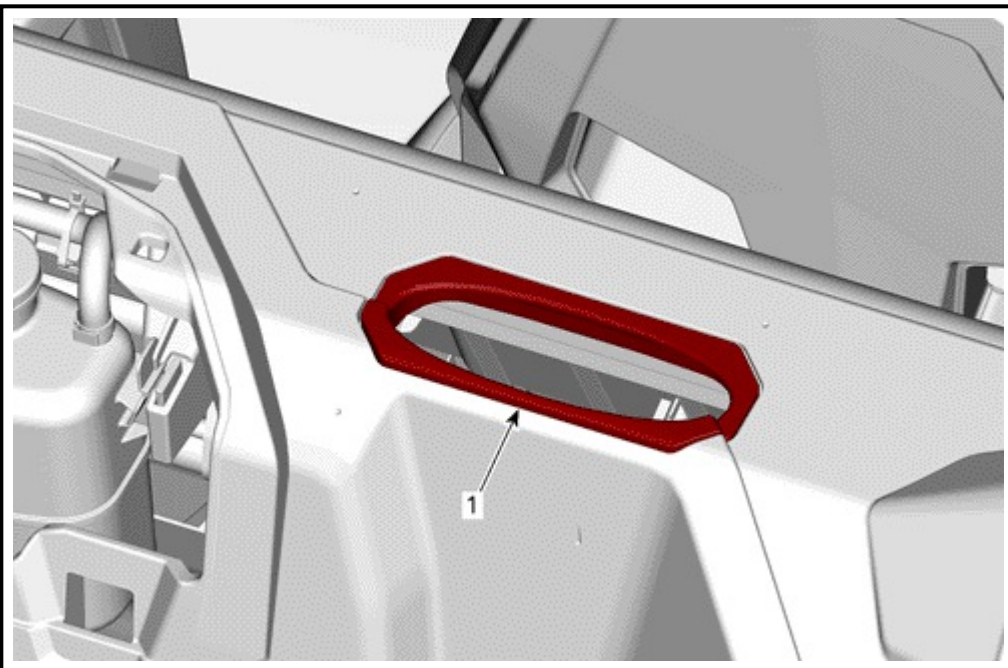

1. Panel snap-in grommet [P18]

Install the upper tube [P19] through the panel grommet [P18] into the ellipse coupler [P21]. Tighten hose clamps to specification.

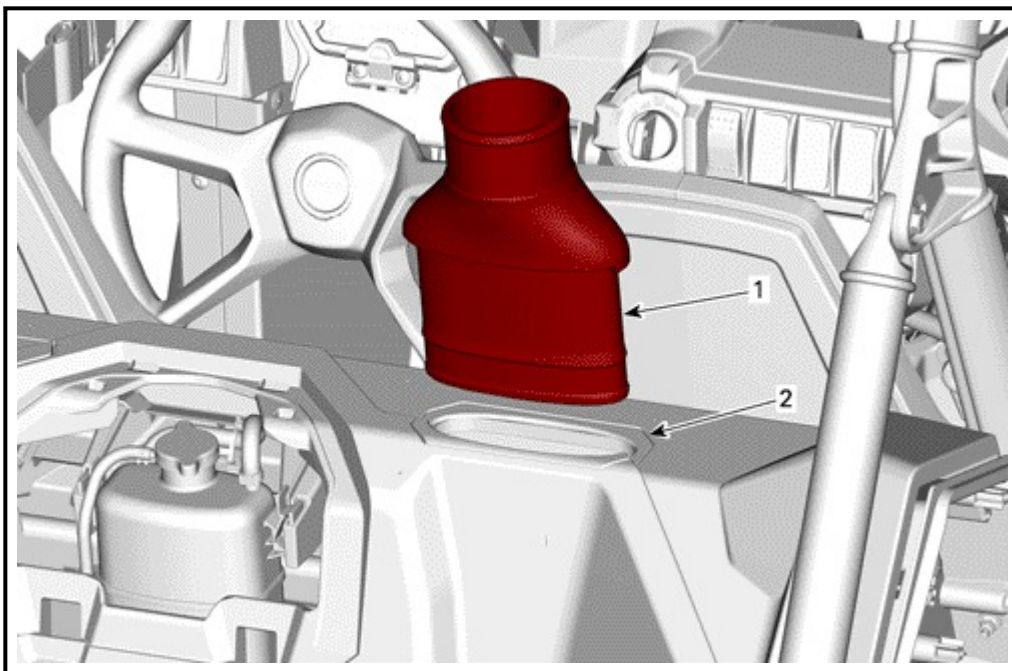

1. Upper tube [P19]
2. Panel grommet [P18]

TIGHTENING TORQUE

Hose clamps #40 [P24]

Hose clamps #72 [P22]

4 N•m (35 lbf•in)

Installation of particle separator

Determine the position of the particle separator [P1] on the cage, make sure there is enough room to fit the clamps and particle separator on the cage without any interference.

Install the two (2) clamp straps (4.7 cm (1.85 in)) [P5] onto the cage. Do not pull the ends of the strapsto force it. Loosely wrap some felt or plastic around the cage and push the straps onto the cage until they snap into place. Leave the plastic on the cage for now to prevent scratching the paint while you adjust the position of the particle separator [P1].

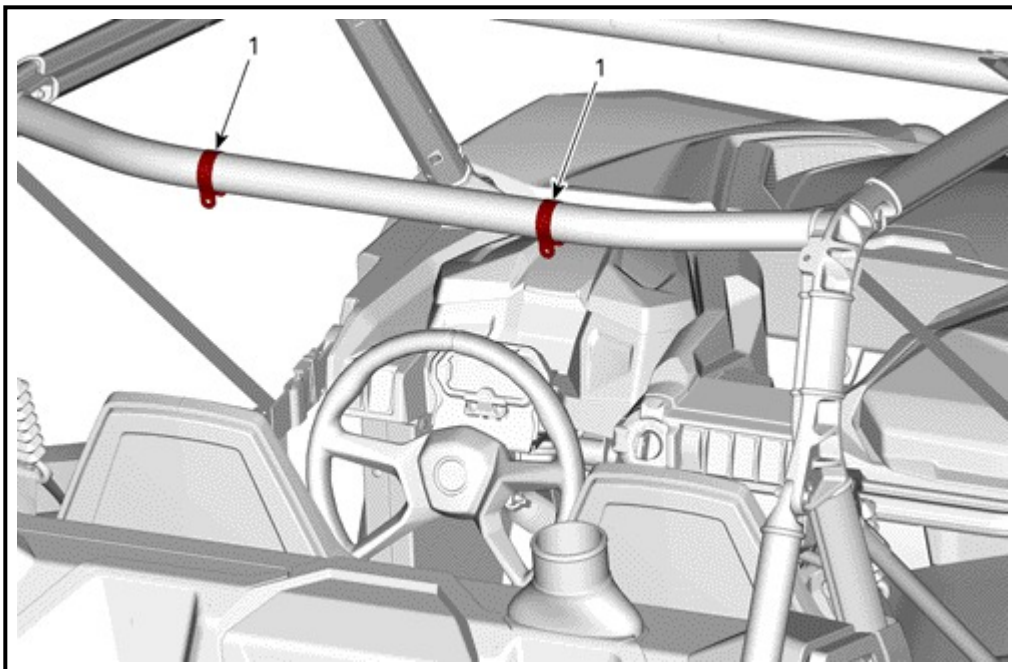

1. Clamp straps (4.7 cm (1.85 in)) [P5]

Install the clamp pivot [P4] onto the clamp strap (4.7 cm (1.85 in)) [P5] using one (1) M6 X 50 button socket cap screw [P10], two (2) M6 fender washers [P7] and one (1) M6 nylon locknut [P11]. Do not fully tighten the screws and locknuts. Repeat for both clamps.

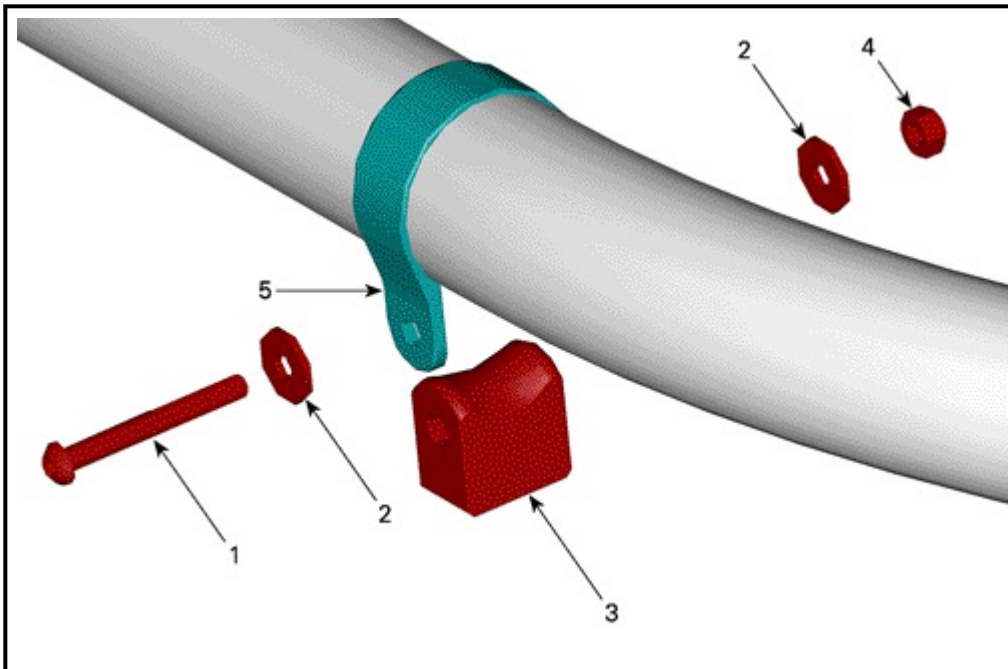

1. M6 X 50 Button socket cap screw [P10]
2. M6 Fender washers [P7]
3. Clamp pivot [P4]
4. M6 Nylon locknut [P11]
5. Clamp strap (4.7 cm (1.85 in)) [P5]

Install the clamp adapter [P2] on the mounting bosses of the particle separator [P1] using two (2) M6 X 18 button socket cap screw [P6] and two (2) M6 fender washers [P7]. Apply threadlocker [P25] to the screw before tightening. Torque to specification.

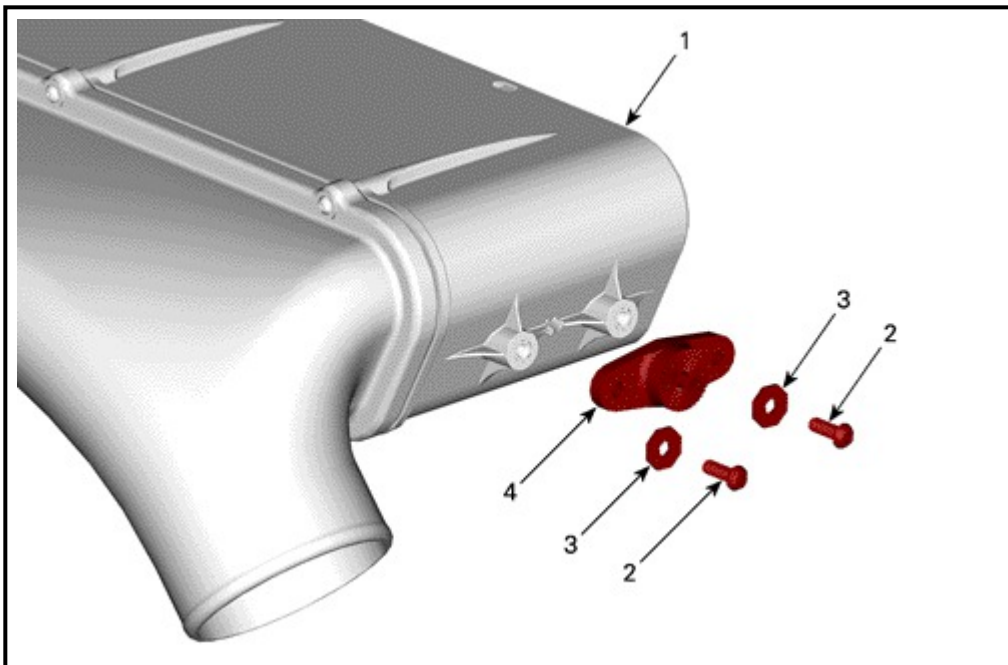

1. Particle separator [P1]
2. M6 X 18 Button socket cap screw [P6]
3. M6 Fender washers [P7]

4. Clamp adapter [P2]

TIGHTENING TORQUE	
M6 X 18 Button socket cap screw [P6]	7.5 ± 1 N•m (66 ± 9 lbf•in)

Determine the proper angle to mount the clamp L-Bracket [P3] to the clamp adapter [P2] based on the desired location for the particle separator [P1].

Once the position is appropriate, install M8 X 25 button socket cap screw [P8], M8 fender washer [P9] onto the clamp L-Bracket [P3].

NOTE: Make sure the ribs in the Clamp L-Bracket are properly seated inside the grooves of the clamp adapter. Do not attempt to rotate these parts once assembled. They are designed to lock into place once seated.

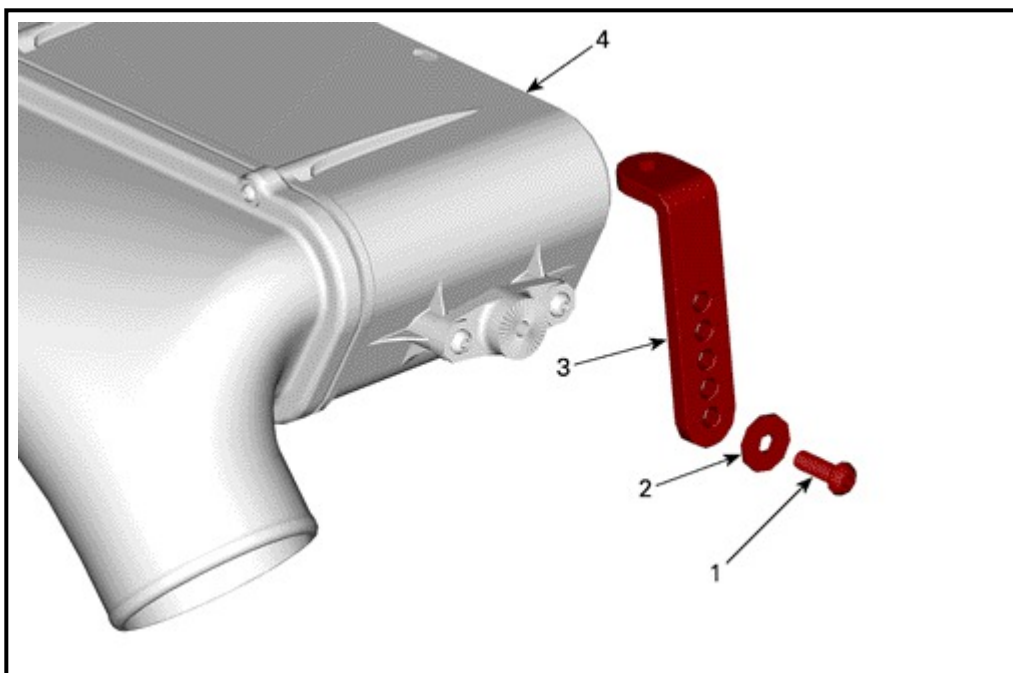

1. M8 X 25 Button socket cap screw [P8]

2. M8 Fender washer [P9]

3. Clamp L-Bracket [P3]

4. Particle separator [P1]

Apply threadlocker [P25] to the screw before tightening. Tighten to specifications.

Repeat for the other side of the Particle Separator and make sure the L-Brackets on both sides are pointed in the same direction and are aligned with each other.

TIGHTENING TORQUE	
M8 X 25 Button socket cap screw [P8]	15.3 ± 1.7 N•m (135 ± 15 lbf•in)

Install the assembly of the particle separator [P1] onto the clamp pivot [P4] using two (2) M8 X 25 button socket cap screws [P8] and two (2) M8 fender washers [P9].

NOTE: If needed, adjust the position of the clamp strap [P5] and clamp pivot [P4]. Do it for both sides. Having an extra pair of hands holding the particle separator [P1] to help align the mounting holes will make the installation easier.

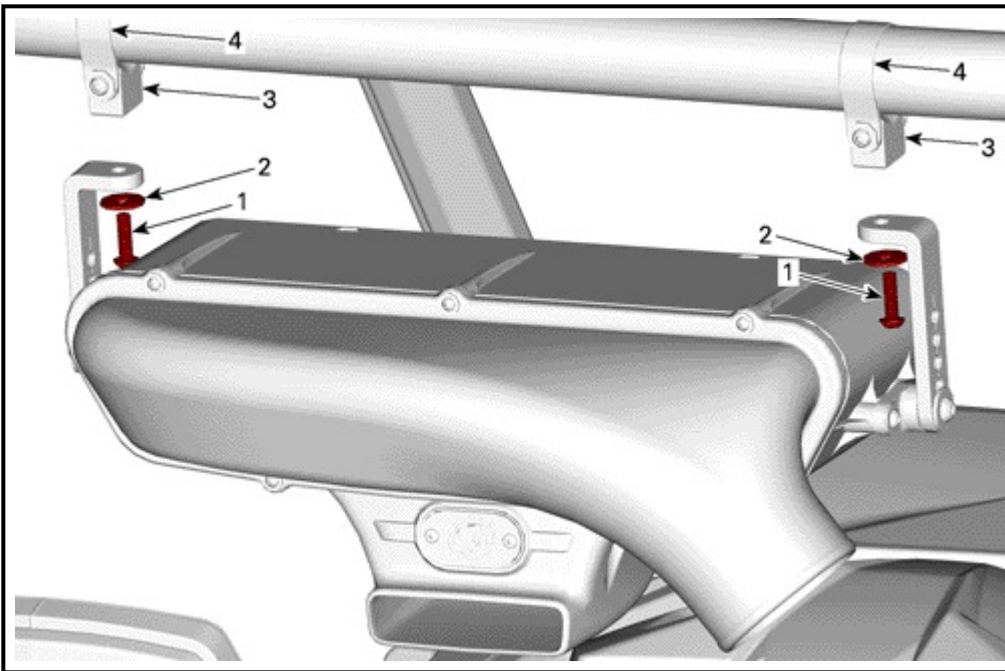

1. M8 X 25 Button socket cap screws [P8]
2. M8 Fender washers [P9]
3. Clamp pivot [P4]
4. Clamp strap [P5]

Apply threadlocker [P25] to the screw before tightening. Tighten to the torque specifications.

TIGHTENING TORQUE

M8 X 25 Button socket cap screw [P8]

$15.3 \pm 1.7 \text{ N}\cdot\text{m}$ ($135 \pm 15 \text{ lbf}\cdot\text{in}$)

When satisfied with the position of the particle separator [P1], remove the felt or the plastic bag around the cage.

Tighten two (2) M6 nylon locknuts [P11] to specification.

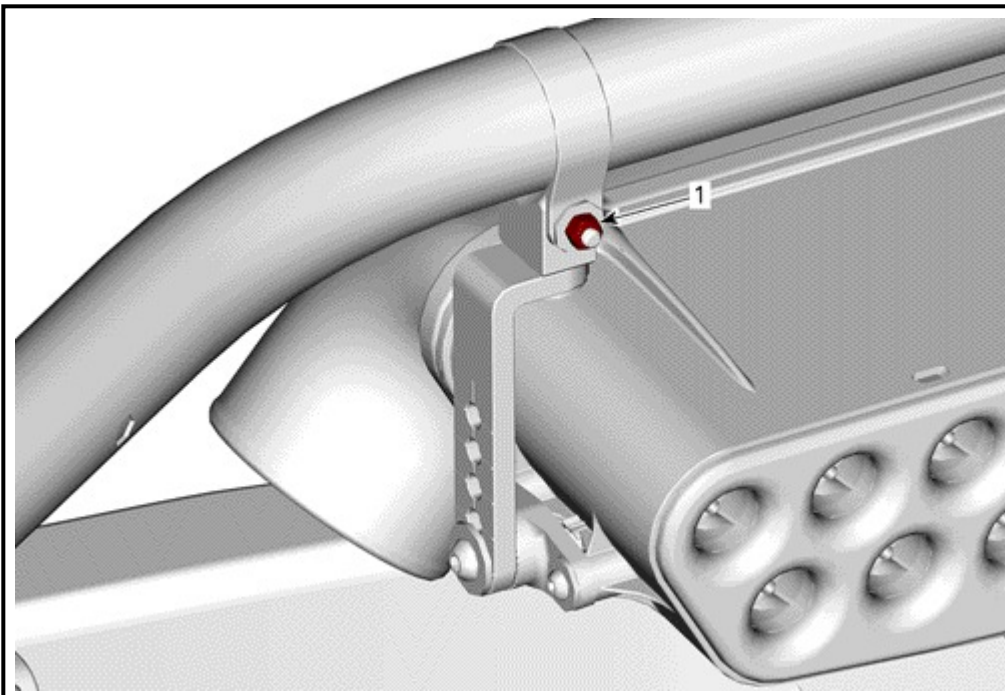

1. M6 Nylon locknut [P11]

TIGHTENING TORQUE

M6 nylon locknut [P11]

 $7.5 \pm 1 \text{ N}\cdot\text{m}$ ($66 \pm 9 \text{ lbf}\cdot\text{in}$)

Note the amount of the flexible duct [P14] to be cut by inserting one end into the upper tube [P19].

NOTE: Add 7 cm (3 in) extra to the length of the duct needed.

Remove the flexible duct [P14] from the upper tube [P19] and the particle separator [P1] and cut to the desired length.

Insert one end of the flexible duct [P14] fully into the flexible duct end cuff [P15] and hose clamp #56 [P16]. Repeat for the other end of the flexible duct.

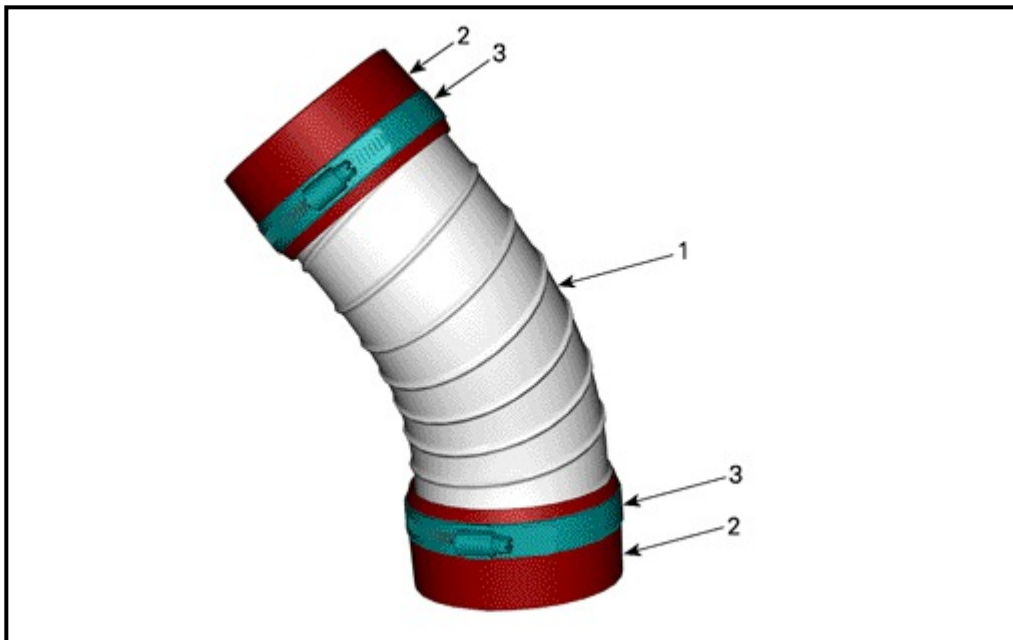

1. Flexible duct [P14]
2. Flexible ducts end cuff [P15]
3. Hose clamps #56 [P16]

Install one (1) end of the flexible duct [P14] onto the upper tube [P19]. Tighten hose clamp #56 [P16]. Install the other end onto the plenum on the particle separator [P1]. Tighten hose clamps #56 [P16] to specification.

NOTE: Make sure the hose clamps [P16] are seated in the groove of the flexible duct end cuff [P15].

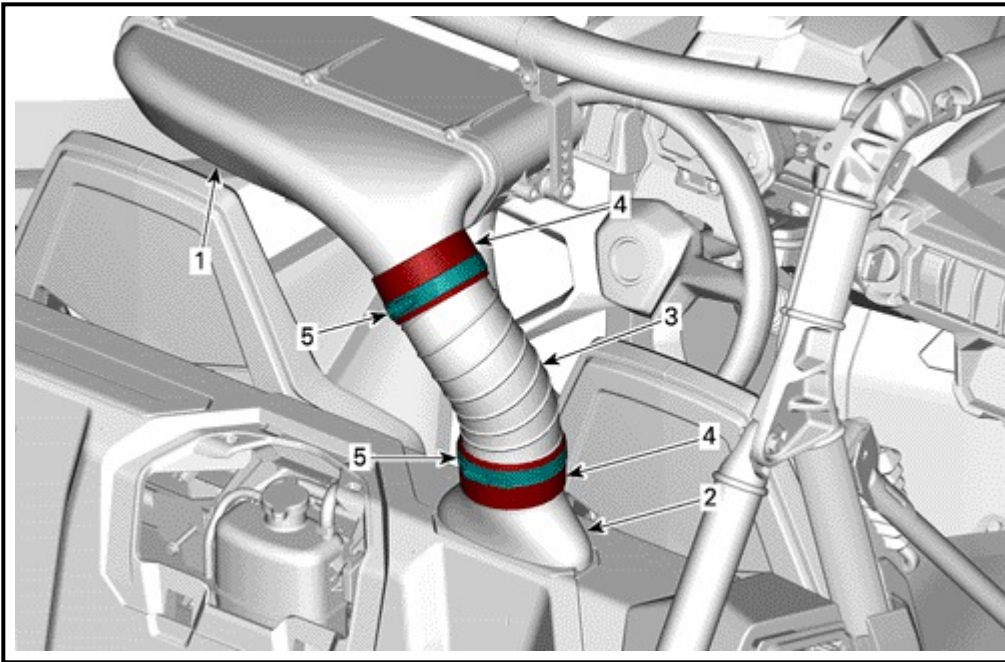

1. Particle separator [P1]
2. Upper tube [P19]
3. Flexible duct [P14]
4. Flexible ducts end cuff [P15]
5. Hose clamps #56 [P16]

TIGHTENING TORQUE

Hose clamps #56 [P16]

4 N•m (35 lbf•in)

Universal wire installation

Locate the accessories terminal block.

Familiarize yourself with the Universal Wire Harness [P12].

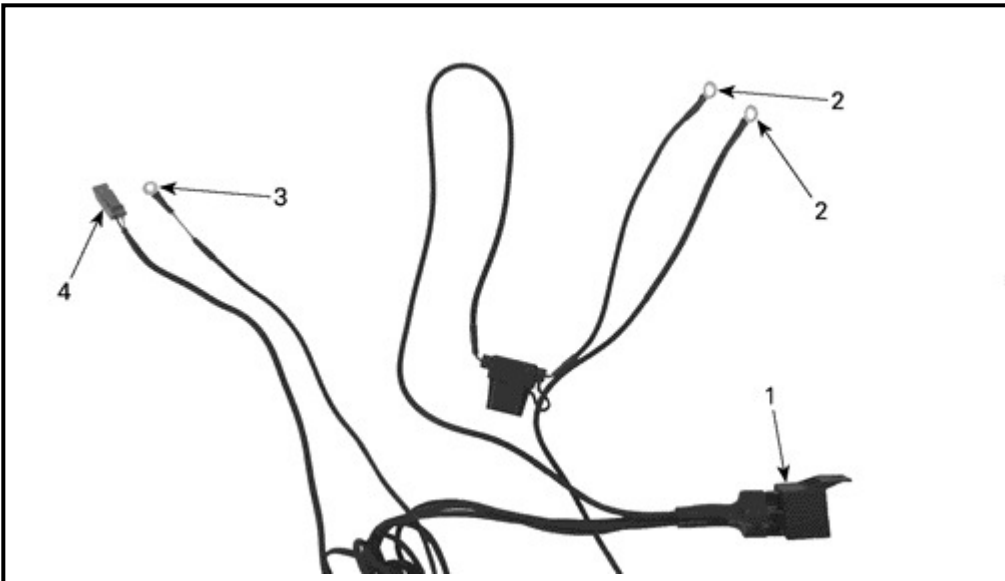

1. Relay
2. Ring terminal
3. Accessory Terminal
4. Fan connector

Disconnect the battery.

NOTE: Always disconnect the battery before doing any electrical modifications. Disconnect the BLACK negative (-) cable first then disconnect the RED positive (+) cable after.

Install the ring terminals and the accessory terminal from the universal wire harness [P12] onto the accessories terminal block. The red wire goes to the positive terminal, while the black wire goes to the negative terminal.

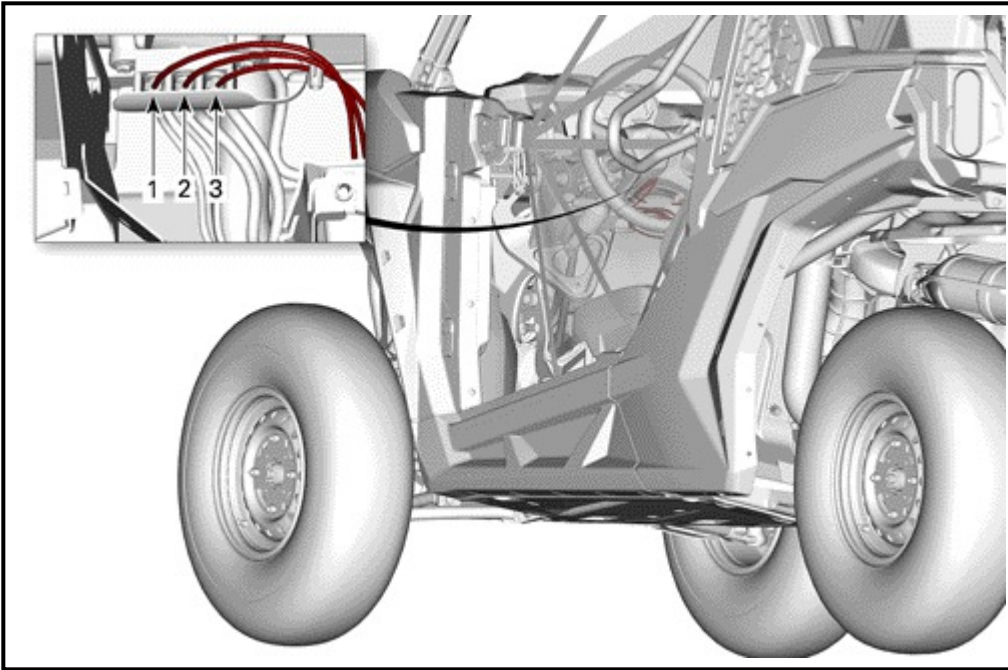

1. Accessory Terminal
2. Positive Terminal
3. Negative Terminal

Route the wire through the center console.

Undo the fan connector from the wire to make it pass through the drilled hole onto the top of the cargo box.

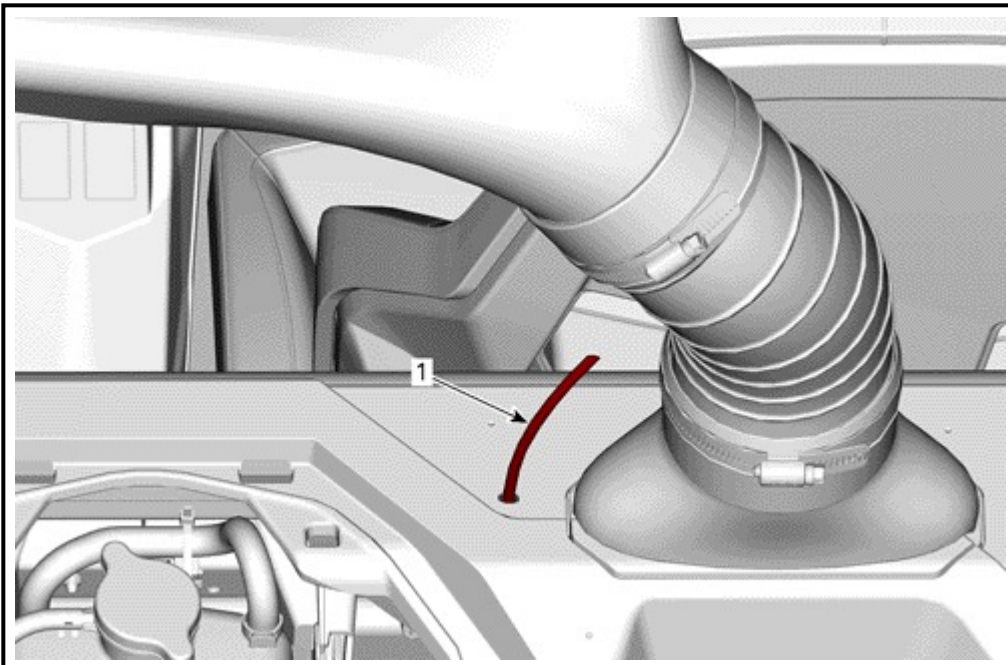

1. Wire

Assemble the fan connector as it was and connect it on the particle separator [P1]. Use the provided Velcro† strap [P17] to secure the wire on the flexible duct [P14].

Reinstall the access cover.

Reinstall the baffle and the grid of the air intake.

Reinstall the air filter access door.

Turn the ignition on and make sure the air is blowing out the exhaust. If the exhaust fan does turn on, double check your electrical connections.

† Velcro is a trademark owned by Velcro Industries B.V.

[Template.pdf](#)