

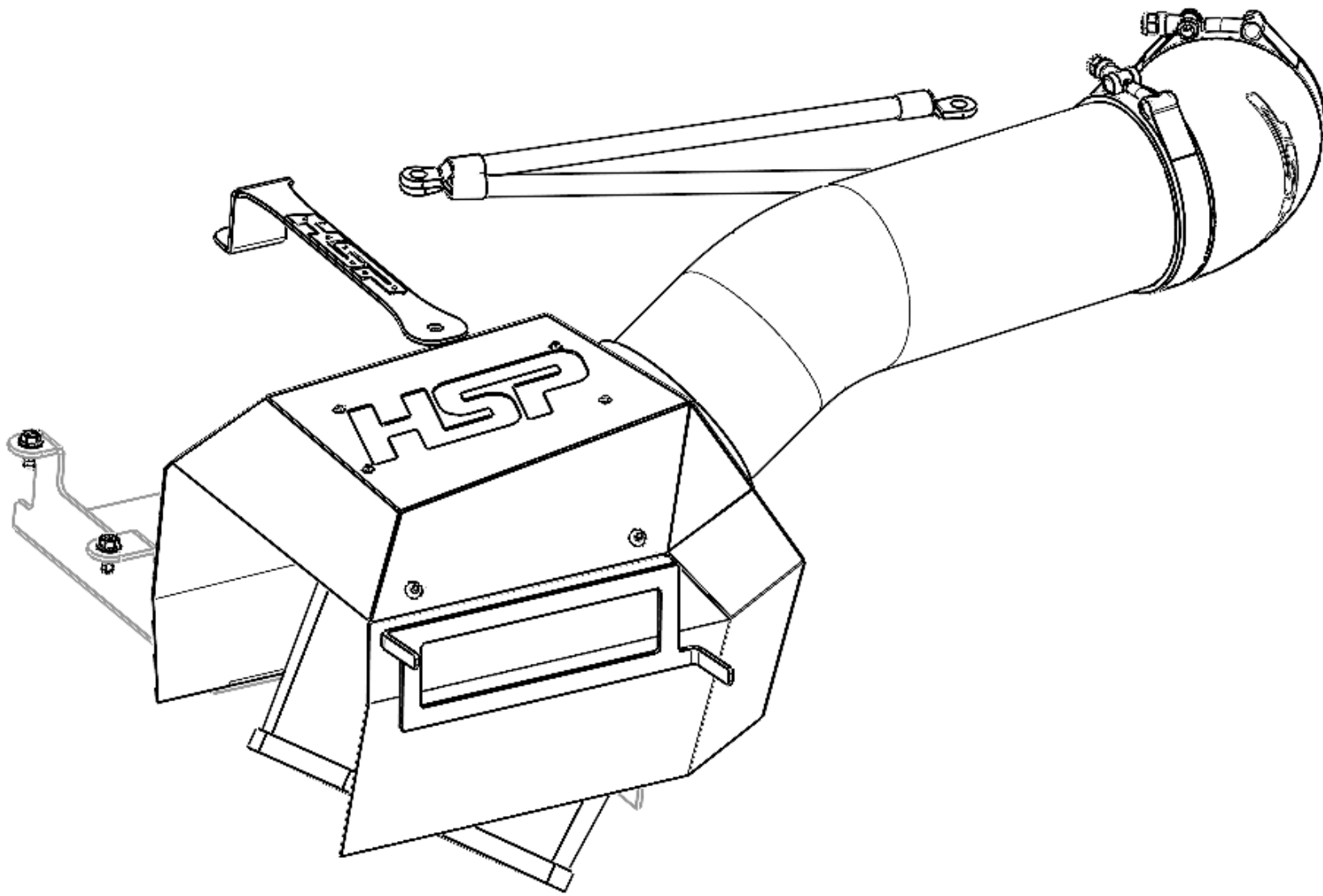

# Installation Guide

HSP INTAKE AND INTERCOOLER BUNDLE KIT FOR 2017-  
2019 FORD POWERSTROKE F250/350 6.7L



## What You'll Need

- T20 Torx bit
- 3mm Allen
- 7mm Socket
- 8mm Socket
- 10 mm Wrench or Deep socket
- 11mm Deep socket
- 13mm Socket
- Flathead screwdriver

1. Disconnect both truck batteries
  - 10mm loosen positive & negative wire

2. Pull out old intake
  - Disconnect plastic clips on the lid
  - Unscrew clamp on intake lid and pipe with a flathead screwdriver



3. Disconnect the MAF sensor connector by pulling out the red tab and pushing down on sensor connector while pulling straight out



**4.** Loosen boot connection on the factory throttle body



**5.** Pull off the lid, filter and plastic intake pipe

**6.** Remove MAF sensor block from the factory intake with a T20 torx bit



7. Use an 8mm socket to remove the lower box tab bolt



8. Remove MAF wire clip from factory box

9. Pull the lower box straight upwards out of the engine bay to remove



**10.** Use an 8mm socket to remove the 2 ground wires attached to the inner fender



**11.** Use a 10mm deep socket to remove the battery tie down

**12.** Remove the battery from the truck



**13.** Use a 13mm socket and extension to remove the 4 battery tray bolts from the truck

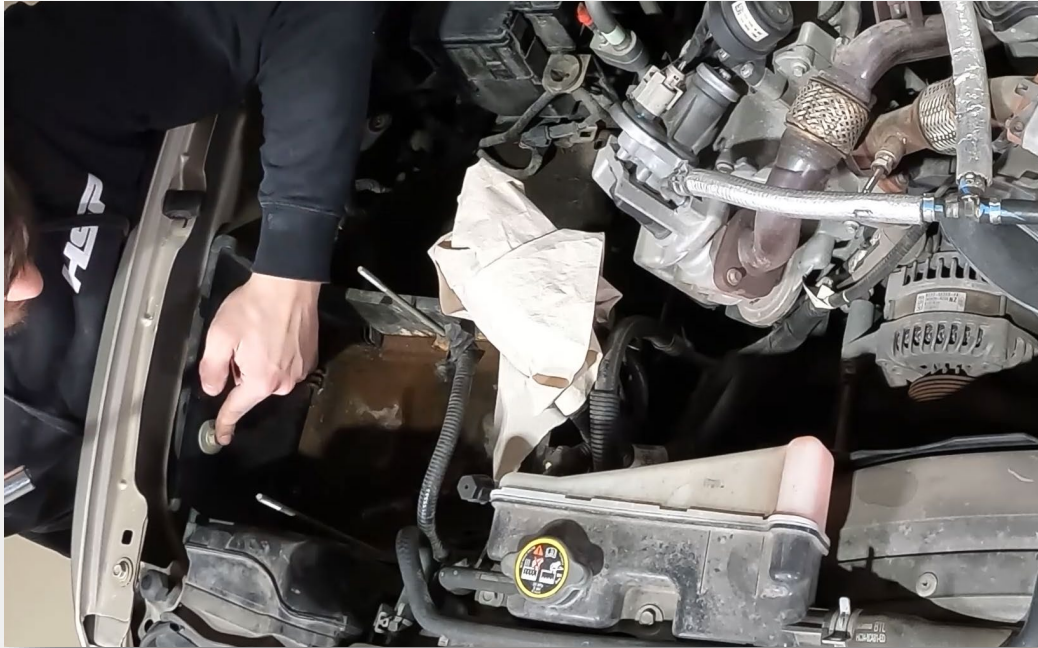

**14.** Disconnect the intake scoop by prying up on the push pin connector with a flathead screwdriver

**15.** Remove tray & wires



**16.** Disconnect the front half of the scoop from the OEM battery tray by removing the 2x 8mm bolts



**17.** Disconnect the battery tray from the scoop using the 2 plastic release tabs on the underside of the tray and scoop

**18.** Remove the U bolt from the factory battery tray





**19.** Install L bracket into engine bay using factory bolts and a 13mm ratchet



**20.** Assemble U bolt in bottom of the HSP battery tray, short side of the U bolt goes in the rear

**21.** Install battery tray onto L bracket in the truck, 2x 8mm bolts go into the L bracket and 2x 6mm bolts go into the fender tabs



**22.** Reattach the rear ground to the fender with an 8mm socket

**23.** Install the lower heat shield box, 2x 6mm bolts go to the L bracket connection and 1x 6mm bolt goes to the battery tray connection



**24.** Install the battery into the battery tray, positive terminal goes towards the drivers side of the engine bay

**25.** Install HSP battery tie down, match the short side of the tie down with the short side of the battery U bolt and tighten



**26.** Disassemble the positive battery terminal  
\*assembly of the battery extension cables\*

**27.** Use provided fiberglass heat wrap on the positive cable and  
MAF wire as necessary

**28.** Attach two battery extension cables with 6mm bolts

**29.** Shrink wrap the extension cable connections with provided heat shrink  
to prevent corrosion and unwanted electrical shorting



**30.** Connect cables to the positive terminal

**31.** Connect remaining grounds

**32.** The truck should now have power coming from both batteries



**33.** Install the 4.5" boot and clamps to the throttle body



**34.** Install the MAF sensor into the MAF sensor block in the intake tube with a 3mm allen key, be sure to match flow direction on the sensor

**35.** Push the intake tube into the boot MAF block should be facing the passenger side rear direction



**36.** Connect the MAF sensor cable to the MAF sensor



**37.** Put air filter on the intake tube and align filter with hole in box



**38.** Tighten clamps on the throttle body, air intake pipe and filter

**39.** Install lid on to heat shield box, use 4x black push pins to fasten lid to heat shield box



**40.** Install factory scoop on front of heatshield box, 2 tabs on scoop go inside of the 2 tabs on the heat shield box

**41.** Enjoy more power, turbo noise, spool up and fuel efficiency

