

ZUMA

Product Guide



audiovolt.co.uk

AudioVolt
HOME AUDIO & LIGHTING SPECIALIST

Purchase your Zuma Lumisonic and Luminaire from us
and receive free industry leading customer support

audiovolt.co.uk Telephone: 02476 36 98 90

Before fitting the Zuma unit to a ceiling, check the perimeter of the hole to ensure the material is sound and not damaged, frayed or waterlogged in any way.

The Zuma unit weights 1.2kg. When fitting, always support the Zuma unit with at least one hand and never let it hang from the power cable.

As with all ceiling speaker installations, the sound produced by Zuma units may cause the ceiling to vibrate slightly in operation. Before fitting each Zuma unit, ensure that the ceiling space is clear of debris and that wires are stapled securely to secure surfaces such as joists etc to minimise any risk of vibration.

3.3. Retaining Springs

Retaining springs on the Zuma unit are a special feature that enables quick and easy fitting or removal from a ceiling location. When not installed, the springs are retracted by twin keys fitted through the Zuma unit mounting plate.



Only remove the keys from the Zuma unit when the speaker is fully installed in a ceiling. When the keys are removed, sharp metal springs will coil down from the body of the Zuma unit and may risk damage to fingers etc. Never remove the keys when holding the body of the Zuma unit.

Retain at least one set of keys in a safe place after installation in case you need to remove Zuma units at any time.

Never attempt to operate the spring release with any tool or device other than keys supplied by Zuma Array Ltd.

4. In Use

When powered on after a first time install, the Zuma unit will enter discovery mode. Download the Zuma iOS app from the App Store and follow the instructions to set up your areas. You will need iOS 14.4 or later.

5. Maintenance

5.1. Cleaning

The lamps in the Zuma unit will run hot when in use. Always switch off the Zuma unit and allow them to cool before touching them.

Only clean the Zuma unit with a dry cloth. Never clean the Zuma unit with abrasives or solvents.

5.2. Uninstalling the Zuma unit

In the unlikely event that the Zuma unit should be uninstalled:

- Ensure that mains power is switched off at the consumer unit.
- Separate the bezel trim from Zuma unit.

- Support the Zuma unit with one hand then insert the keys to retract the springs.
- Lower the Zuma unit and disconnect the power cable, then place it in a safe area.
- Leave the keys in place whilst removing the Zuma unit from the ceiling.

5.3. Lamp replacement

Zuma unit lamps are long-life LED designs. The lamps are not user replaceable. In the unlikely event that a lamp fails, contact Zuma array Ltd customer services for assistance.

6. Troubleshooting

Please view the Zuma unit instruction manual at www.zuma.ai for a full list of hardware troubleshooting tips.

7. Warranty

The Zuma unit is intended to be used under the conditions defined in this document. Failure to adhere to these conditions will risk invalidating the warranty.

The time period of your warranty will be determined by your original point of purchase. Please refer to your original point of purchase for additional information.

In the event that Zuma Array Ltd has diagnosed the product as damaged or faulty, please refer to your original point of purchase to make a warranty claim. For all warranty claims, you will need to provide proof of purchase.

For additional warranty information, please visit www.zuma.ai

8. Disposal



The crossed out wheeled bin label that appears on the back panel of the product indicates that the product must not be disposed of as normal household waste. To prevent possible harm to the environment please separate the product from other waste to ensure that it can be recycled in an environmentally safe manner. Please contact your local authority or original point of purchase for collection.

9. Contact

For additional help and to get the most from your Zuma system, please visit www.zuma.ai/help or email us at help@zuma.ai

Designed in the U.K.. made in China.



10. Declarations

IEC 62368-1	Safety of Product System
IEC 62471	Safety of LED Lighting
IEC 62031	Safety of LED Module
IEC 61347-1/2	Safety of DC/DC Power Module
UL 2043	Fire Test
EN61000 -3-2 and 3-3 EN55032/EN55035	EMC
EN60598-1 and EN60598 2-2	Safety for Luminaires
EN300328	Wideband transmission systems
EN301893	Broadband radio access networks
EN301489-1 and 17	EMC for radio equipment
EN62311	Human exposure to magnetic fields
2014/35/EU	Low Voltage Directive
2014/53/EU	Radio Equipment Directive
2014/30/EU	EMC Directive
EC 1275/2008 and EU 801/2013	Standby power consumption
EU Directive 2011/65/EU	RoHS Directive



The Bluetooth® word mark and logos are registered trademarks owned by Bluetooth® SIG, Inc. and any use of such marks by Zuma Array Ltd. is under license. Other trademarks and trade names are those of their respective owners.



The Wi-Fi CERTIFIED logo is a registered trademark of the Wi-Fi Alliance. Wi-Fi Certification provides assurance that the device has passed the interoperability test conducted by the Wi-Fi Alliance, a group that certifies interoperability among wireless LAN devices.



Amazon, Alexa and all related logos are trademarks of Amazon.com, Inc.



The Spotify software is subject to third party licenses found here:
<https://www.spotify.com/connect/third-party-licenses>.



Use of the Works with Apple badge means that an accessory has been designed to work specifically with the technology identified in the badge and has been certified by the developer to meet Apple performance standards. Apple, iPad, iPad Air, iPad Pro, iPhone and AirPlay are trademarks of Apple Inc., registered in the U.S. and other countries. To control this AirPlay 2 enabled speaker, iOS 11.4 or later is required.

Read Before Starting Installation

Important Safety Cautions

Planning Your Installation

Installation

In Use

Maintenance

Troubleshooting

Warranty

Disposal

Contact

Declarations

1. Important Safety Cautions

! This product must only be installed by a competent person to the current edition of the IEE wiring regulations BS7671 and relevant building regulations. The installer must be trained and experienced in the installation of electrical fittings in the home. If you are in any doubt about your skills to install the product, refer to an electrical installation professional.

! Only remove the keys from the Zuma unit when the speaker is fully installed in a ceiling. When the keys are removed, sharp metal springs will coil down from the body of the Zuma unit and may risk damage to fingers etc. Never remove the keys before installing the Zuma unit in your ceiling or you may risk injury.

! All warnings and cautions on the product, in this document and the installer guide should be adhered to. This document and the installer guide should be read by the professional installer and owner before the product is installed or operated. This document and the installer guide should be retained after the installation.

! This product cannot be covered by insulation materials

1.1. Electrical

Always switch off mains power at the consumer unit before carrying out any installation or maintenance work.

To reduce the risk of electrical shock do not remove any unit covers or panels from the Zuma unit or power supply except to gain access to the power supply connections. There are no fuses or other user serviceable parts in this product. If the covers are removed this will invalidate the warranty.

To reduce the risk of electric shock, never operate the Zuma unit if the Zuma unit or the power supply has been exposed to water or moisture from a water leak. In this case the Zuma unit and power supply must be removed from the installation and contact Zuma Array Ltd customer services for further advice.

Never push objects of any kind into this product through openings as they may touch dangerous voltage points or short-out parts that could result in a fire or electric shock.

When fitting the DC out cable to the power supply, ensure that the cable polarity is correct.

This product is intended for indoor use. Never install it outdoors.

Do not use attachments not recommended by the product manufacturer as they may cause hazards.

Only use devices approved by Zuma Array Ltd on the rear USB-C connector of the product. Using devices which are not supported by Zuma Array Ltd will void warranty.

This product is designed to be installed in a ceiling as a source of light and sound. Never install the product in any other location or use it for any other purpose.

1.2. Power Supply

Each Zuma unit is supplied with a power supply. Use only power supplies provided by Zuma Array Ltd. Ensure to wire the power supply with the correct polarity. The product or power supply may be damaged or become unsafe if used with another power supply.

Check the power supply cables for cuts or splits. Never use a power supply if the cables have been damaged in any way.

If the power supply becomes defective contact Zuma Array Ltd for a replacement.

For Y type attachments: If the external cable or cord of this luminaire is damaged, it shall be exclusively replaced by the manufacturer or his service agent or a similar qualified person in order to avoid hazard.

2. Planning Your Installation

! This product must only be installed by a competent person to the current edition of the IEE wiring regulations BS7671 and relevant building regulations. The installer must be trained and experienced in the installation of electrical fittings in the home. If you are in any doubt about your skills to install the product, refer to an electrical installation professional.

2.1. Site Survey

The Zuma unit is intended to be installed in plasterboard ceilings of thickness between 12mm to 30mm. If your ceiling has a different construction or thickness outside of these limits, it is still possible to install Zuma units. Check the help page on the Zuma Array Ltd website at www.zuma.ai/help for more information and suggestions on installation in these structures.

Ensure that there is at least 13cm height in the ceiling to accommodate the product before commencing installation. If there is not enough clearance, check the Zuma help page on the Zuma Array Ltd website at www.zuma.ai/help for advice.

Before installing your Zuma units, check there are no electric cables, water pipes or gas pipes within the area where you will be installing the Zuma units.

Never cut through joists during installation as this will weaken the structure of the building.

If the space around the Zuma unit is insulated, ensure that the

insulation is cut back to allow 10cm clearance on all sides of the Zuma unit.

Ensure that there is no insulation above the Zuma unit as per fig 1.

Ensure to plan the wiring. Each Zuma power supply will draw a 'surge' of power when switched on. For this reason a maximum of 9 x Zuma units can be connected to any lighting circuit fed with a 6A type B MCB or there may be a risk of activating the circuit breaker occasionally. If you are planning to install more than 9 x Zuma units on a single switched circuit, the circuit breaker and all wiring in that lighting circuit should be updated to a higher capacity.

NOTE: The surge only occurs when the Zuma power supplies are switched on at the mains so in larger installations, set up groups of 9 x Zuma units or less, each controlled by a separate light switch to reduce the switching surge.

A local disconnect device such as a light switch is recommended in all installations.

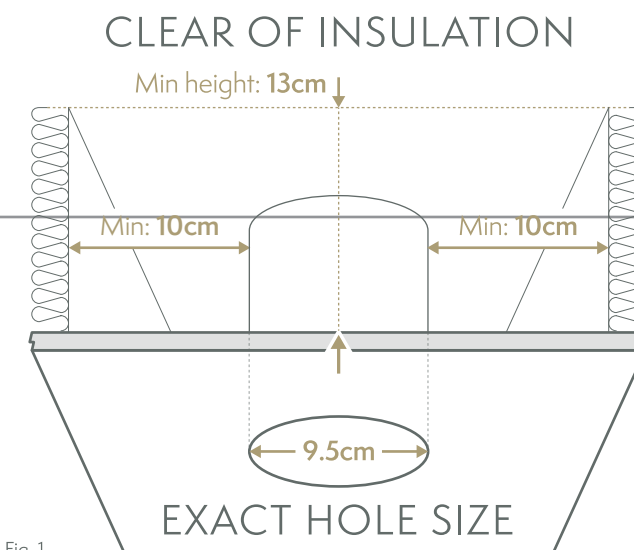

Fig. 1

2.2. Network and Wi-Fi

Check the network speed in the install location using an online, network speed tester. This will need to be a minimum of 10Mb/s for reliable operation of a single cluster of Zuma units. Consider that other network usage will reduce the available bandwidth.

Check Wi-Fi signal strength in each room before installing Zuma units. A Wi-Fi scanning app is recommended for this. Consider that the building structure and other electrical devices may impede performance. If Wi-Fi signal strength is lower than -70dBm, avoid using wireless repeaters as these will establish separate SSIDs from the main network. If you are installing in locations where Wi-Fi signal is low, consider upgrading your Wi-Fi network. Contact Zuma Array Ltd customer services for further advice.

2.3. Temperature

The Zuma unit will function over a wide range of temperatures from 0°C (32°F) to 40°C (104°F), but will not function correctly in locations that exceed this temperature range and the life may be shortened. This may typically occur in flat roof installations or in attic spaces which are solar loaded.

2.4. Vibration and sound transmission

Playing loud music from ceiling speakers may sometimes transmit sound to rooms above the listening room. To reduce the level of sound transmitted, fix sound deadening panels under the floor above the listening room. These panels should not encroach the insulation around the unit.

2.5 Fire resistance

Always check local building regulations for fire protection system requirements that might apply to the installation of Zuma units before commencing installation. Amongst other things, regulations may require systems involving an additional fire rated back enclosure or the use of specialist sealing products for the Zuma depending on the location of the Zuma unit. Please refer to the Zuma Array Ltd website for specific fire rated back enclosure recommendations.

Zuma Array Ltd take no responsibility for the correct specification and installation of any such fire protection system that is required behind their products.

3. Installation

3.1. Tools and fixings

Installing Zuma units requires the minimum of tools.

Electrical tools including screwdrivers and wire cutters will be required.

A pipe/wire detector may be required for new installations though will this will not detect plastic pipework. Always proceed with caution and if in doubt, consult a professional.

A 95mm (3¾") hole saw will be needed to cut holes.

In retrofit installations where Zuma units will replace existing, smaller luminaries, please use a hole saw adapter to create 95mm hole concentrically around your existing hole.

3.2. Installation Cautions

Always switch off mains power at the consumer unit before carrying out any installation or maintenance work.

Remove dimmers from any circuits that will feed Zuma units. Replace them with switches.