

## APPLICATIONS

- Band P.A.
- Personal monitor
- Small theatres
- Auditoriums
- Piano bar
- DJ
- Stage monitor
- Conference rooms
- Fixed installations in live clubs
- Pubs
- Gyms

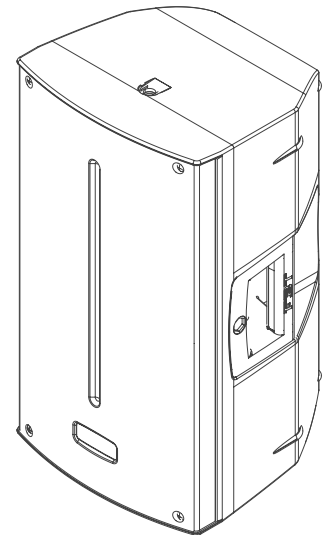

## KEY FEATURES

- 2 way bi-amplified system in bass-reflex
- Polypropylene molded enclosure
- Woofer custom 10" (LF) / 2.5" voice coil
- 1" throat / 1.4" voice coil HF compression driver
- 1200W / 300W Built-in amplifier (LF / HF)
- Bluetooth 5.0
- 3-channels mixer
- 4 DSP presets
- 30° / 45° monitor taper
- Universal switching mode power supply 100 - 240 VAC
- M10 rigging points

## PRODUCT DESCRIPTION

The FBT XLITE 110A series speakers with integrated 3-channels mixer feature lightweight, yet rugged gas injected molded polypropylene cabinet construction. Available in black finish, the FBT XLITE 110A series speakers provide fixed installations with an elegant design that blends into any decor. The asymmetrical shape of the FBT XLITE 110A cabinet also allows use as a powered floor stage monitor. The FBT XLITE 110A is two way design incorporating a 10" low frequency woofer and 1" HF compression driver coupled to a 90°H x 60°V constant directivity horn. With a frequency range of 58Hz - 20kHz the FBT XLITE 110A speaker provide high fidelity sound for both speech and music applications with a maximum SPL of 127dB. The bi-amplified FBT XLITE 110A active speaker feature a 1200W low frequency amp and a 300W high frequency amp. The control panel features a three-channel mixer with two micro-line inputs, a stereo input and a dedicated channel for bluetooth 5.0; two xlr inputs, stereo input, xlr output with ch1 or mix link selector, hp filter, two mic-line selectors, dsp preset selector, bluetooth 5.0 with pairing led. 4 x M10 rigging points built-in into the cabinet along with the optional mounting brackets allow the FBT XLITE 110A speaker to be surface mounted on walls or ceilings. A standard 1.38" speaker stand socket allows the FBT XLITE 110A to be mounted on speaker stand.

## ELECTRONIC SPECIFICATIONS

System Types	2 way
Internal Amplifiers* peak LF/HF	1200/300 W
Input Impedance	22 kOhm
Frequency Response	58Hz - 20KHz
Maximum SPL peak**	123/127 dB
Dispersion	90°x60°
AC Power Requirement	500 W

## PHYSICAL SPECIFICATIONS

Low Frequency Woofer	10 - 2.5 coil
High Frequency Driver	1 - 1.4 coil
Input Connectors	XLR IN/OUT, Jack ST
Net Dimensions (WxHxD)	inch 11,81 x 21,10 x 11,87
	mm 300 x 536 x 301,5
Shipping Dimensions (WxHxD)	inch 14,56 x 24,21 x 14,96
	mm 370 x 615 x 380
Net Weight	28,66 lbs / 13 Kg
Shipping Weight	32,62 lbs / 14,8 Kg
Enclosure Material	Polypropylene
Grille	Steel with powder coated black paint finish
Power Cord	16,4ft / 5mt

\* Max.: 2mS burst, rms power on nominal speaker impedance

\*\*Peak SPL: free space, based on max. peak power amp rating and system peak sensitivity, 10mS time average

### DIMENSIONAL DRAWINGS

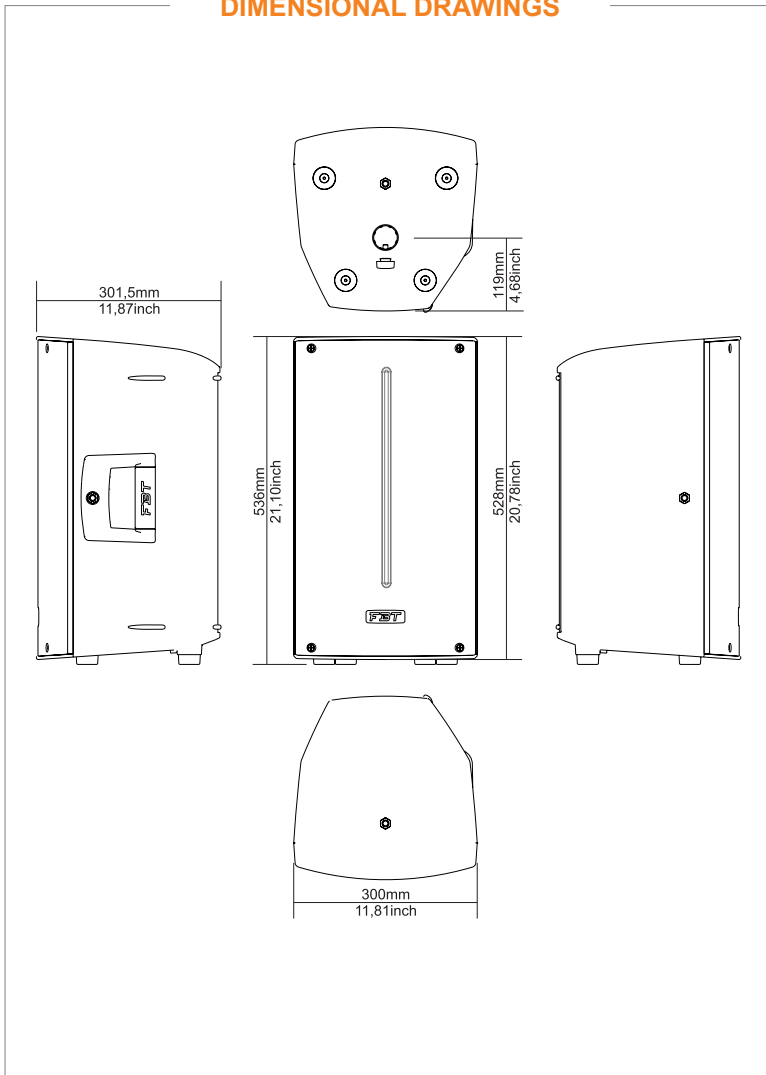

### CONTROL PANEL

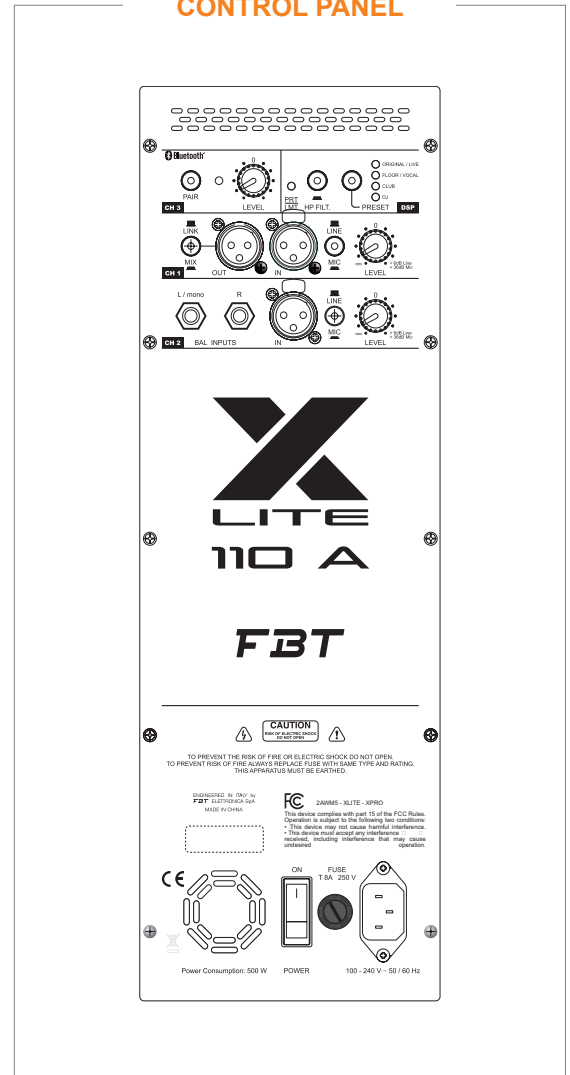

### ACCESSORIES

