

# MODEL RTA-0044D

## ASSEMBLY INSTRUCTIONS

Thank you for purchasing our product.

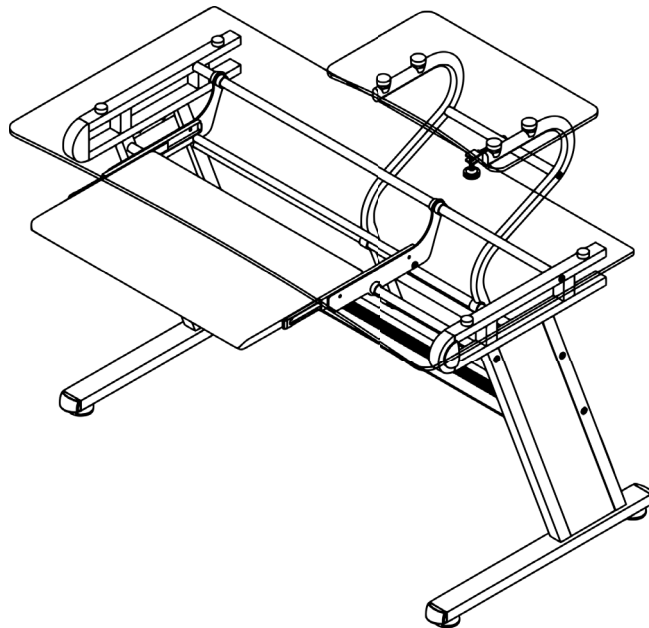



- Please read carefully the assembly instructions before the installation.











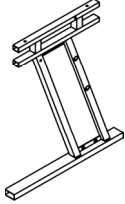

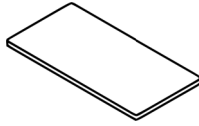
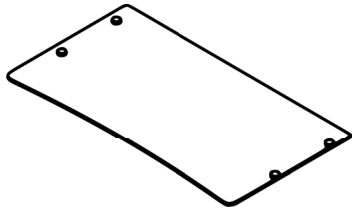
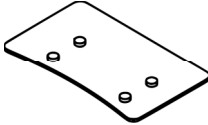
- Do not discard this manual or any of the packaging material until the unit has been completely assembled.

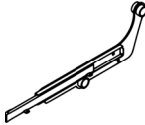
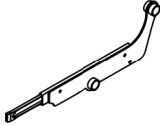
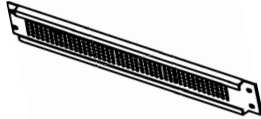



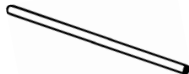











- Might require two people.

**MAIN PARTS LIST**

<p><b>1</b> x1</p> <p>Left structure</p> 	<p><b>2</b> x1</p> <p>Right structure</p> 	<p><b>3</b> x1</p> <p>Keyboard panel</p> 	<p><b>4</b> x1</p> <p>Main glass panel</p> 	
<p><b>5</b> x1</p> <p>Adjustable glass panel</p> 	<p><b>6</b> x1</p> <p>Left shelf stand</p> 	<p><b>7</b> x1</p> <p>Right shelf stand</p> 	<p><b>8</b> x1</p> <p>Left slider</p> 	<p><b>9</b> x1</p> <p>Right slider</p> 
<p><b>10</b> x1</p> <p>Lower back panel</p> 	<p><b>11</b> x1</p> <p>Lower short stand tube</p> <p>12.9" (328mm)</p> 	<p><b>12</b> x2</p> <p>Back lower long tubes</p> <p>42" (1068mm)</p> 		
<p><b>13</b> x2</p> <p>Top long tubes</p> <p>39.5" (1004mm)</p> 	<p><b>14</b> x1</p> <p>Sliders support tube</p> <p>24.4" (621mm)</p> 	<p><b>15</b> x1</p> <p>Upper short stand tube</p> <p>11.8" (300mm)</p> 		

**LIST OF HARDWARE, SCREWS AND FITTINGS**

PART	QTY	ITEM	
A	2	Top caps	
B	4	Lower caps	
C	4	Stand caps	
D	1 Set	Stand clamp	
E	4	Glass studs	
F	4	Lower glide studs	
PART	QTY	ITEM	
G	18	M6x1.25x27	
H	4	M6x1.25x40	
I	4	M6x1.25x50	
J	4	ST3.5x12	
K	1	M8x1.25x60	
L	1	Wrench (spanner)	
M	1	4mm Allen	
N	1	5mm Allen	

**BEFORE YOU START THE ASSEMBLY, PLEASE READ THE FOLLOWING TIPS AND WARNINGS.**

**1** Do a quick inventory to make sure the package contains all the parts and hardware listed in the assembly instructions.



**7** To avoid misalignments, always leave the screws loose and tighten them until all pieces are positioned correctly.

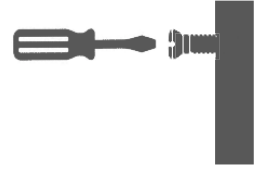

**2** Missing, damaged and defective parts can be replaced at no cost to you. Please refer to the last pages on this manual.



**8** Do not overtighten or force the screws as they might break, strip, damage the threads of the holes or get stuck inside the part.

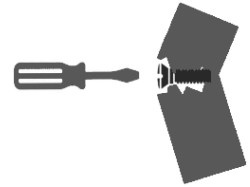

**3** The replacement parts service is limited to the 48 contiguous United States. If you reside in Alaska, Hawaii, Puerto Rico, U.S. territories or other countries, please contact the supplier from where the unit was purchased.



**9** Sometimes the laminate might cover partially or entirely the hole on a panel. If there is no visible hole for the screw, pass and press the tip of your finger over the area where the hole should be located to feel the indentation, and once found, carefully pierce the laminate to reveal the hole underneath.



**4** If during assembly you find an issue or need clarification, please contact our Customer Service for assistance. Please refer to the last pages on this manual.



**5** On each step read the instructions and analyze the illustrations thoroughly before proceeding to do the assembly.



**10** If the hole seems too small for the screw, first make sure you are using the correct size of screw and that it's been installed in the correct hole. If the hole still appears to be too small, carefully pierce the laminate to reveal the hole's actual size.



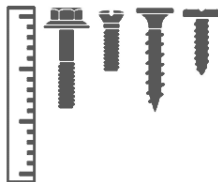

**6** Make sure you understand which hardware will be used on each step. Using the wrong size of screw, bolt or pin might strip the threads or cause damage to the part in which it is being used.



**ASSEMBLY STEPS**

**STEP 1**

**Hardware:**

<b>A</b>		2 Pcs
<b>B</b>		4 Pcs
<b>F</b>		4 Pcs

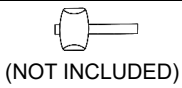

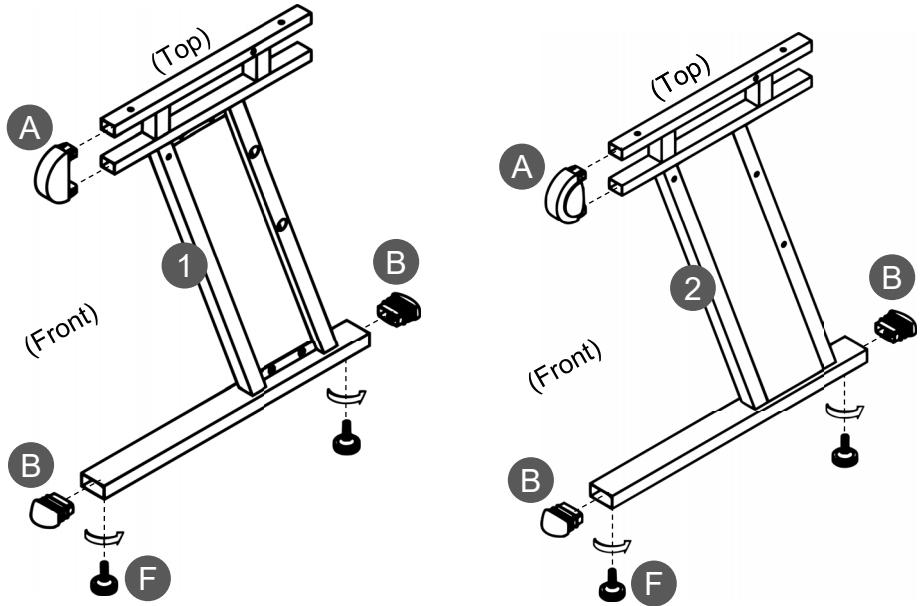

- Insert the end caps **A** and **B** into the structures **1** and **2**, making sure that the caps **B** go in with their nuts facing **DOWN**.
- Insert the lower studs **F** through the legs and into the nut of caps **B**.



**STEP 2**

**Hardware:**

<b>G</b>	 M6x27	4 Pcs
<b>C</b>		4 Pcs
<b>M</b>		4mm

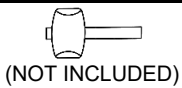

- Assemble the lower and upper short stand tubes **11** and **15** in between the shelf stands **6** and **7** at the top and bottom respectively with screws **G**.
- Insert the long tubes **12** through the stands as shown.
- Attach the caps **C** to the top and bottom of the stands as shown.

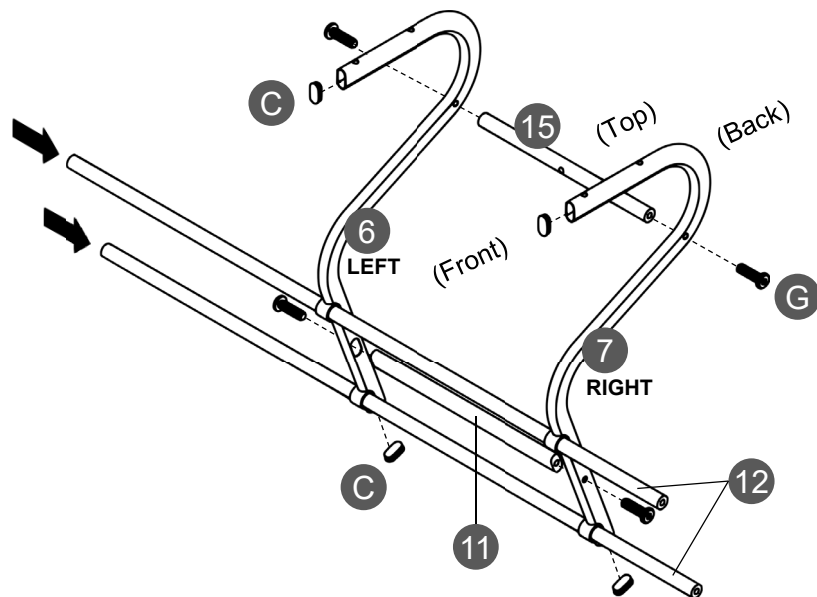

**STEP 3**

**Hardware:**



- DO NOT TIGHTEN ANY SCREWS IN THIS STEP, leave them loose to allow flexibility to install the stand from step 4.
- With the help of another person, assemble the tubes **12** from the structure built in step 2 in between the structures **1** and **2** with screws **G** as shown.
- Assemble the lower back panel **10** to the bottom with screws **G**.

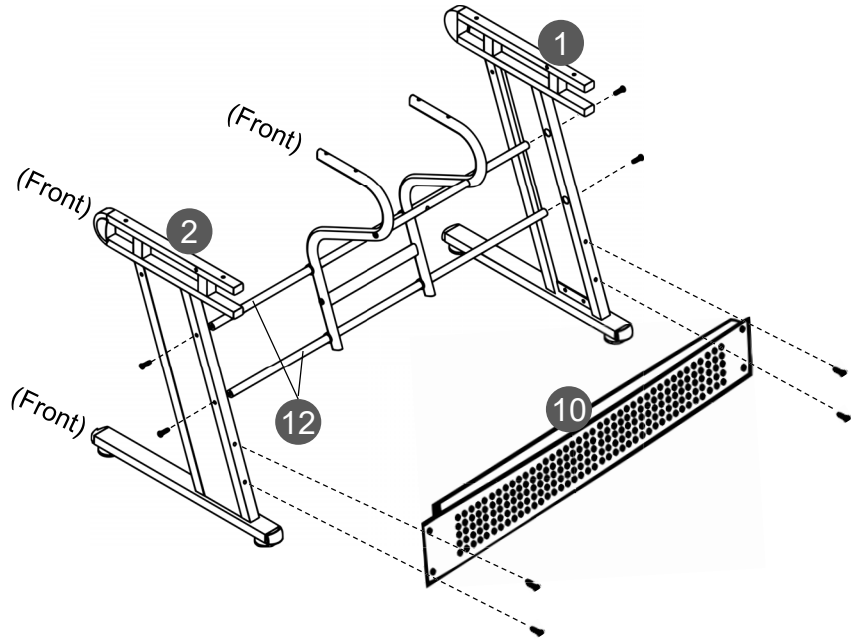

**STEP 4**

**Hardware:**

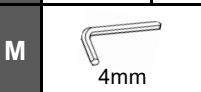

- Assemble the support tube **14** in between the sliders **8** and **9** with screws **G**.
- Insert the long tubes **13** through the sliders **14** as shown.

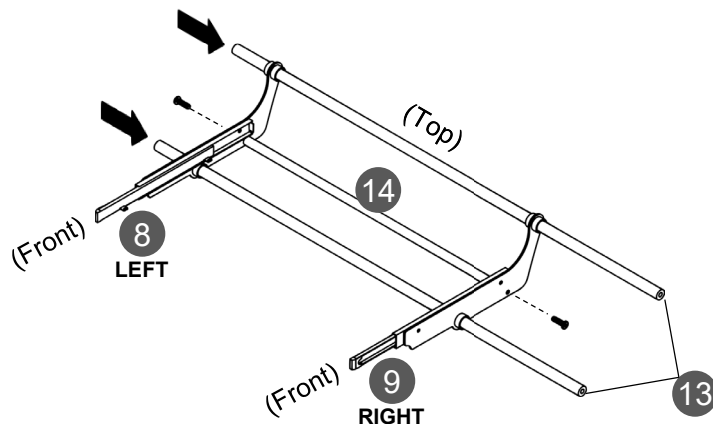

## STEP 5

## Hardware:

I

4  
Pcs

M



4mm



- With the help of another person, assemble the long tubes **13** to the structures **1** and **2** with screws **I** as shown.
- Proceed to tighten all the screws that were left loose in step **3**.

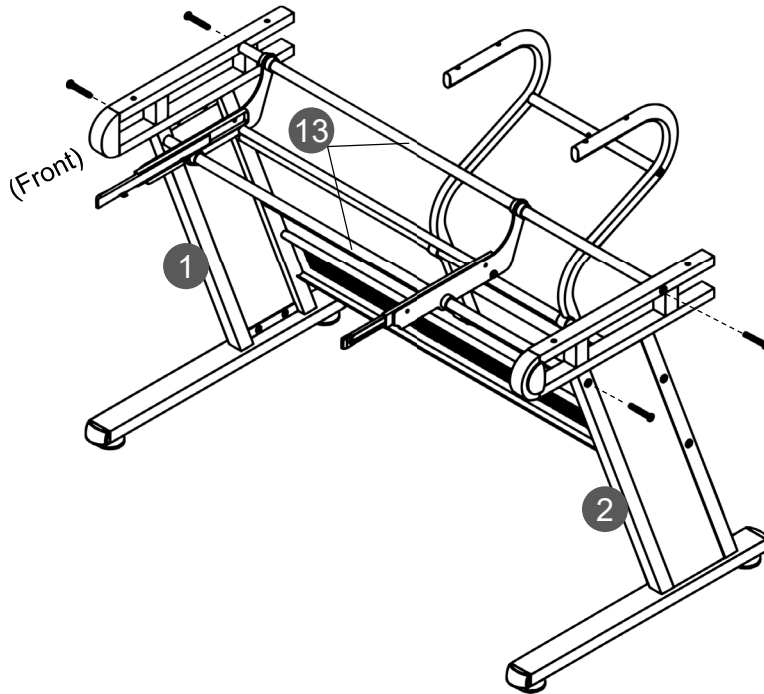

## STEP 6

## Hardware:

J

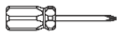
4  
Pcs

(NOT INCLUDED)

- Place the keyboard panel **3** over the tabs of the sliders **8** and **9**, and secure it with screws **J** from underneath.

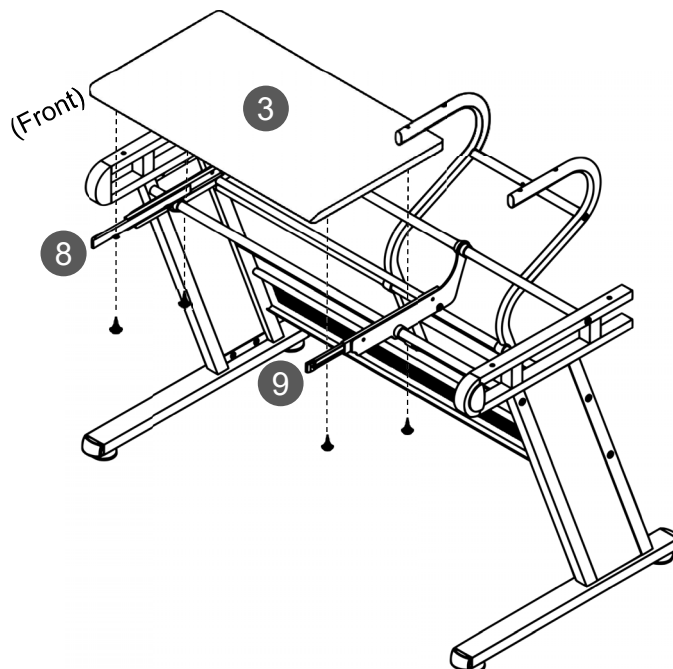

## STEP 7

## Hardware:

G

4  
Pc

M



4mm



- With the help of another person, place the main glass panel **4** over the frame making sure the holes on its metal discs coincide with the holes on the structures **1** and **2**.
- Secure the glass with screws **G** from underneath, but screw loosely to avoid misalignments, and tighten after all the screws are in place.

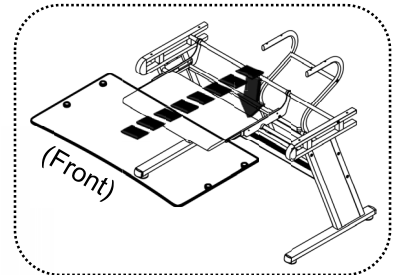
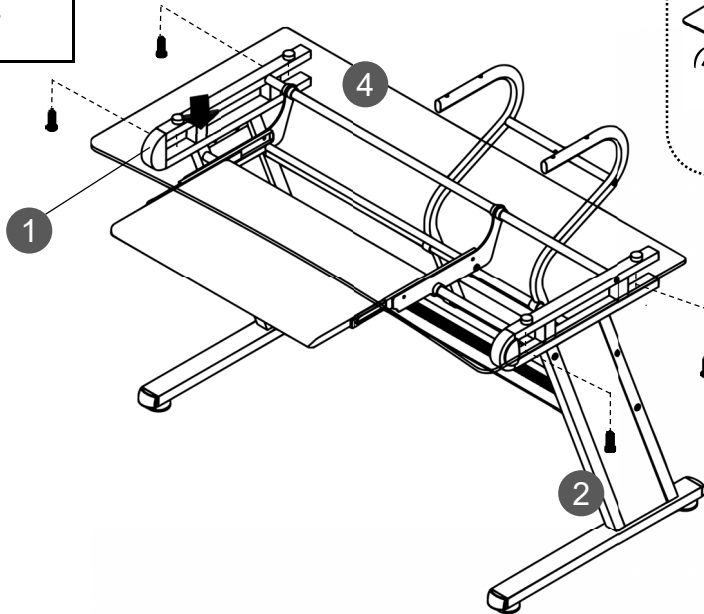

## STEP 8

## Hardware:

D



K

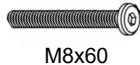

M8x60

N



5mm

L



- Insert the screw **K** through the tube **15**, and on the other side add the **nuts** from the set **D**, and screw into the **clamp** (the clamp attaches to the main glass **13**). Adjust the nuts against the tube and the clamp, and secure them with the wrench **L**. Add the rubber **protector** to the **knob** and screw into the **clamp**, but do not overtighten.

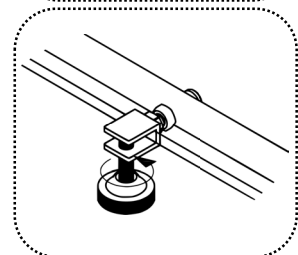
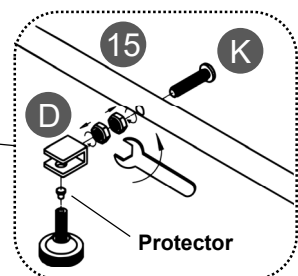
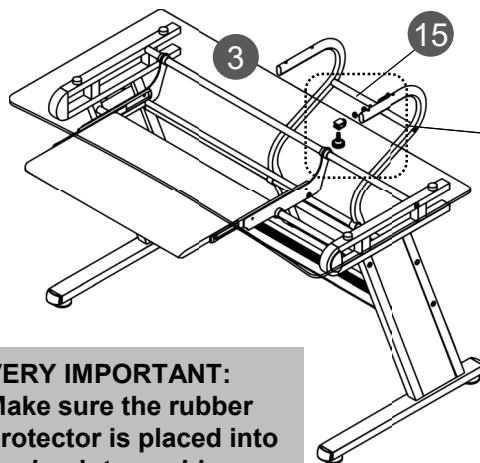



**VERY IMPORTANT:**  
Make sure the rubber protector is placed into the knob to avoid damaging the glass!



## STEP 9

## Hardware:

E		4 Pcs
H	 M6x40	4 Pcs
M	 4mm	

- Place the glass studs **E** over the holes on the shelf stands **6** and **7**.
- Place the adjustable glass panel **5** over the studs making sure the hole from the metal discs coincide with the holes on the studs.
- Secure the glass with screws **H** from underneath. The screws go through the stands and studs and into the discs on the glass.

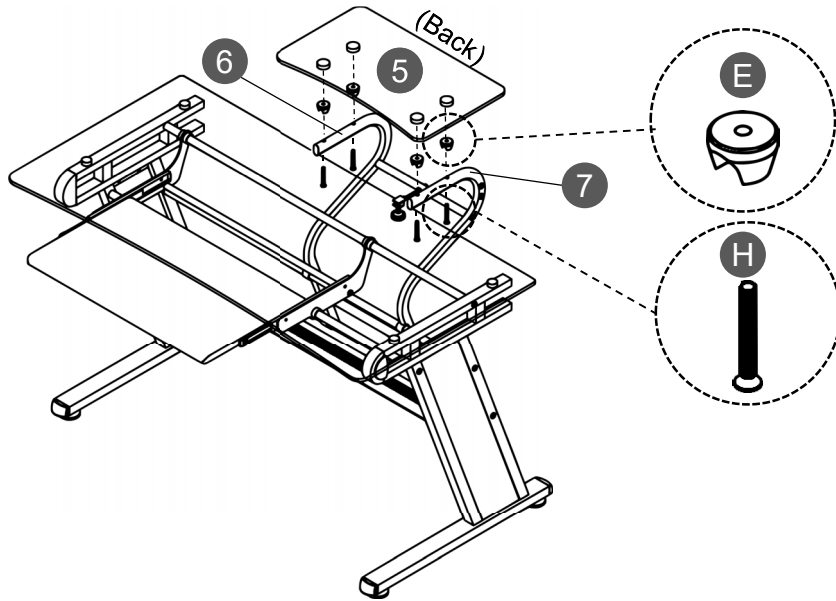

## FUNCTIONS

- 1 You can slide the keyboard tray back-and-forth and side-to-side.
- 2 To adjust the position of the glass shelf, first unscrew the knob, then slide the stand to the new position, then re-tighten the knob, but make sure to not overtighten.

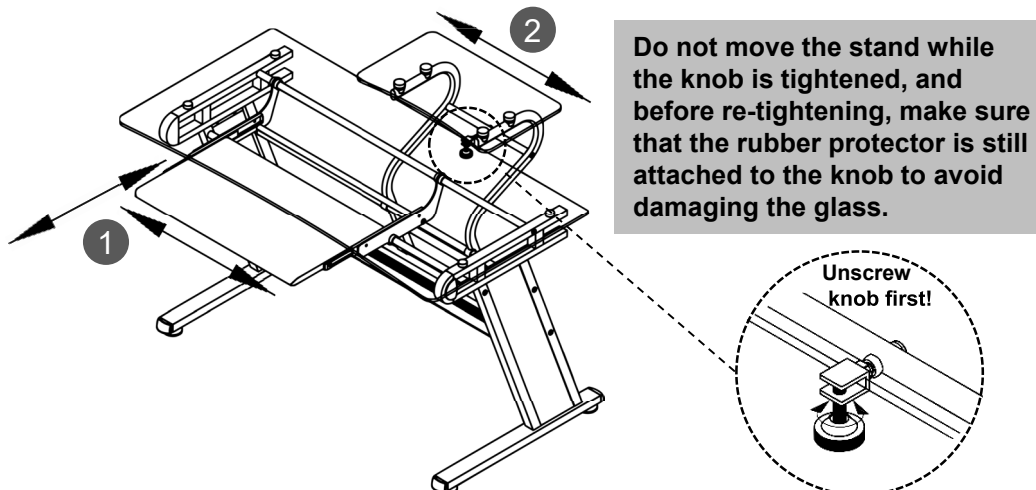

**AFTER THE ASSEMBLY IS DONE, PLEASE READ CAREFULLY THE FOLLOWING CARE AND MAINTENANCE WARNINGS:**

**WEIGHT LIMITS**

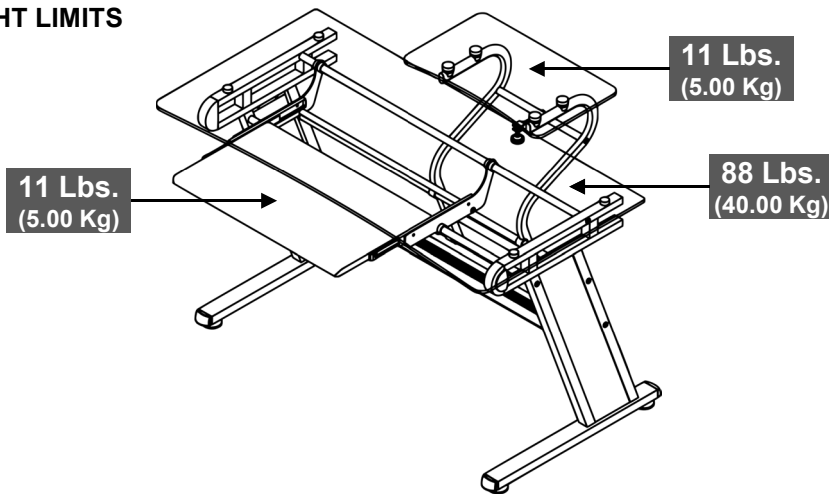

- Do not exceed the indicated weight limits.
- Do not expose the surfaces to direct sunlight or to extreme environmental conditions.
- Clean the surfaces preferable with a clean cloth damped in a solution of mild soap and water, then dry with a clean towel.
- Do not use solvents or abrasive materials to clean the unit.
- If you decide to use a cleaning agent, test first on an area hidden from view such as underneath the tabletop.
- Do not sit on the unit or lean against it.
- Do not allow small children to play under or over the unit.
- Do not allow small children to operate the moving parts without your supervision.
- Do not pull, push or drag the unit to move it for more than 1 feet. The unit must be lifted by at least 2 persons when moving in the same or adjacent rooms.
- Before moving the unit, make sure to secure or remove any object that is heavy or might fall off.
- Always lift the unit from the frame; avoid lifting from the main glass as it could detach from its own metal discs, causing glass damage or even shatter.
- When lifting the unit, use both hands and bend your knees, not your backs.
- When transporting the unit to places far away, protect and secure the unit to avoid damage in transit.
- The glass is made of safety tempered glass. The safety feature is that when breakage occurs, the glass shatters into many tiny pieces minimizing the risk of serious injuries. If the glass breaks, do not handle the pieces with your bare hands, take some pictures and contact Customer Service immediately.
- Shall any part of the unit become defective during the warranty period, replacement parts might be available to you at no charge. Please refer to the last pages on this manual.
- The warranty does not extend to regular wear and tear, nor the manufacturer assumes liability for damages or consequences due to accidents, incorrect assembly, negligence, improper use, modifications, or not heeding the above warnings.

**TECHNI MOBILI WARRANTY**  
**DESKS/LAPTOP CARTS/FILE CABINETS: LIMITED 5-YEAR WARRANTY**  
**TV Stand/Entertainment Center: 2 YEAR WARRANTY**

RTA Products, LLC warrants to the Original Purchaser who acquired a new product from RTA Products or its authorized resellers that this product will be free from defects in its workmanship and materials, under normal use and service conditions, as described herein. "Defects" as used in this warranty, is defined as any imperfections that impair the use of the furniture or product. RTA Products LLC will replace any defective part, at its discretion, and without charge to the original purchaser other than the freight from the end consumer to RTA Products.

Replacement parts can only be supplied if parts are available. Items out of production may be unavailable. This warranty will be effective for the applicable time period beginning the date of purchase on your original sales receipt. RTA product's obligation under this warranty is limited to repairing or replacing products or parts as provided herein. This product has been designed for and is intended for office and home-office use only. This warranty is Original Purchaser's sole remedy for product defects, and this warranty does not extend to any product, or damage to any product, caused by or attributed to abuse or misuse, products used for commercial or rental purposes, use modifications of, or attachments to the product, and products or parts not used, maintained, or extended hereunder is in lieu of any and all other warranties, express or implied, including without limitations any implied warranty or merchantability or of fitness for a particular purpose. Please note, all desks made with PVC Laminate surface should not be exposed to direct sunlight, as it may damage the material. Damage of this nature is not covered under this warranty.

RTA Products will not be responsible for indirect, special, incidental or consequential damages. This warranty is limited to merchandise purchased in the Continental United States. Some States do not allow the exclusion or limitation of incidental or consequential damages, so the above limitations or exclusions may not apply to you. This warranty gives you specific legal rights. You may also have other rights that may vary from state to state.

RTA Products will advise you of the procedure to follow in making warranty claims. The following are the procedures for warranty claims:

- a. Call us Monday – Friday, from 9am-5pm (Eastern Time) at (866) 782-5520 to explain the defect and give your name, address and phone number. Please have ready the model number of our product, date and place of purchase. You can also write to us by e-mail to [warranty@rtaproducts.com](mailto:warranty@rtaproducts.com) and include the same information.
- b. If we determine that replacement will remedy the situation, and in order to determine the extent or the cause of the defect, purchaser will need to send the part in question at purchaser's expense. Once we receive the part, we will examine it and determine whether the claim is valid (or not), and then proceed to send the replacement. We will ship the replacement at our expense.

# FOR SEVERAL HELP OPTIONS INCLUDING REPLACEMENT PARTS ORDERS

---

VISIT: [WWW.TECHNIMOBILI.COM](http://WWW.TECHNIMOBILI.COM)



CLICK ON SUPPORT TAB



Scan QR Code to order replacement parts

OR EMAIL US: [SUPPORT@RTAPRODUCTS.COM](mailto:SUPPORT@RTAPRODUCTS.COM)