



UFO Emergency LED Driver

Date:..... Location:

Product:.....Project:.....

Quantity:..... Catalog#



Design with Junction box

FEATURES

- UL Listed for US and CANADA
- Listed to UL924 and tested to CSA C22.2NO.141 Field or factory installation
- Low energy consumption CECTitle20 compliance
- Constant output power
- Self-testing
- Battery:over temperature protection
- Remote Test Switch: Distance for 98ft(This accessory is optional)
- 4.8V 1800mAh Nickel Cadmium Battery
- Built-in Integrated junction box
- For wiring to the led driver's input

CAUTION

For unit of EMUFO-25170-YY for LED lamp less than 150W (When dimming to a minimum,the power needs to be less than 20w)

For unit of EMUFO-40170-YY for LED lamp less than 300W (When dimming to a minimum, the power needs to be less than 35w)

ACCESSORIES

		
(1) pcs M10 Hanging Ring Bolt	(1) pcsM10Hanging Ring Bolt	(1) pc Suitable for wire diameter 0.118-0.248"(3-6.3mm)(Optional) (2) pc Suitable for wire diameter 0.196-0.393"(5-10mm)(Optional)

DIMENSION

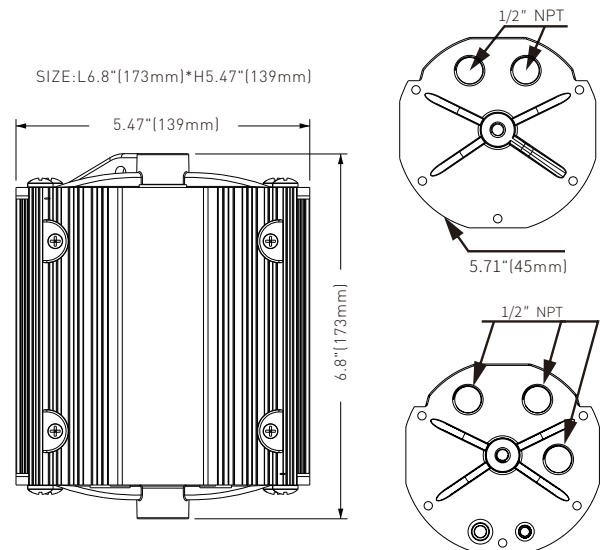

PRODUCT ORDERING GUIDE

EMUFO-40170-YY

1 2 3
EMUFO- 40 170

EMUFO Emergency Driver for UFO HIGHBAY

25W Emergency25W 40W Emergency40W

170 OUT 170V/DC

► Electric Characteristic

Model NO	Input Voltage	Input Current	Input Power Rating	Time Recharge	Output Voltage	Emergency Power	Discharge Time	Vaux	Surge Protection
EMUF0-25170-YY	120-347V/AC	200mA max	12W max	24H	170Vdc	25W	1.5H	12V/DC 0.2A	Line-Neutral 3KV
EMUF0-40170-YY	120-347V/AC	200mA max	12W max	24H	170Vdc	40W	1.5H	12V/DC 0.4A	Line-Neutral 3KV

► Installation instructions

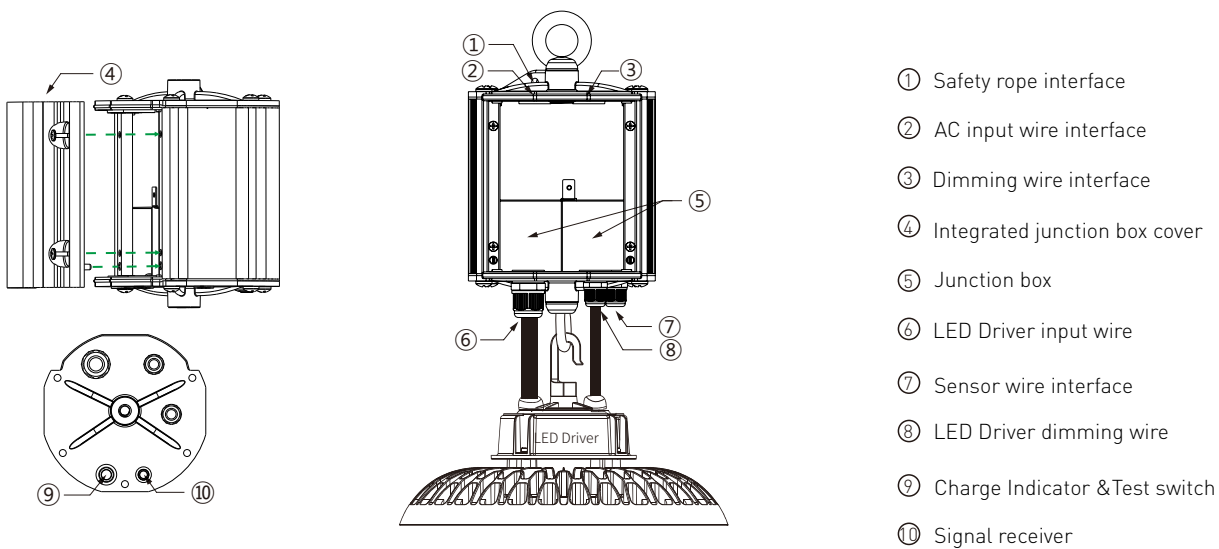

► WIRING DIAGRAM

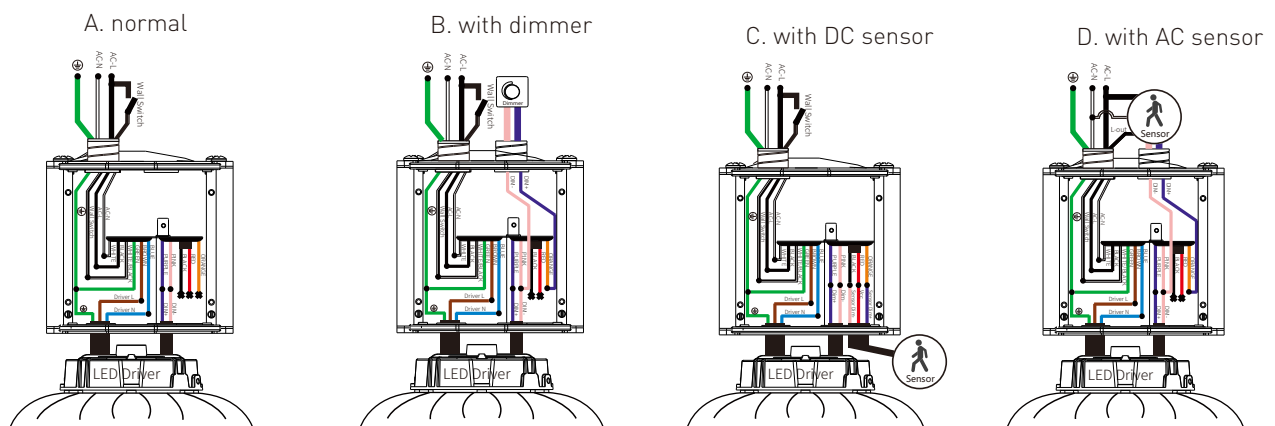

► READ AND FOLLOW ALL SAFETY INSTRUCTION

- CAUTION- This EMUF0 provides more than one power supply output source. To reduce the risk of electrical shock, disconnect both normal and emergency source by turning off the A.C. branch circuit.
- CAUTION- Servicing of this equipment should be performed by qualified personnel only.
- CAUTION- Do not attempt to service the battery. A sealed, no-maintenance battery is used that is not field replaceable. Replace the entire unit when necessary.
- CAUTION- The use of accessory equipment not recommended by the manufacturer may cause an unsafe condition, void warranty, and result in non-compliance with UL specifications.
- CAUTION- The EMUF0 requires an un-switched AC power source of 100-347VAC ,50/60Hz. Installer must confirm that fixtures input voltage covered 120VAC before installation. It will supply power under an output voltage of 170VDC in emergency mode for at least 90 minutes.

6. CAUTION- Battery pack should be charge for 24 hours every 6 months during storage.
7. Battery in this unit may not be fully charged. After electricity is connected to the unit for at least 24 hours, then normal operation of this unit should take effect.
8. For use in 0°C minimum, 50°C maximum ambient temperatures. Suitable for use in damp locations and plenum spaces.
9. Flexible metal conduit is optional, depend on installation environment.
10. The EMUFO should be mounted in locations and at heights where it will not readily be subjected to tampering by unauthorized personnel.
11. Do not use this equipment for anything other than its intended use. Equipment only use for LED Lighting emergency backup.
12. Do not mount near gas or electric heaters. Do not let power supply cords touch hot surfaces.
13. Do not make or leave any other open holes in the wiring enclosure or electrical component enclosure during installation.
14. This fixture is for use with grounded, UL Listed, this model can use in wet location. Not for use in heated air outlets or hazardous locations.
15. The emergency driver have battery inside, forbidden for insulation voltage (I/P-O/P) test.
16. Equipment should be mounted in locations and at heights where it will not be subjected to tampering by unauthorized personnel.
17. The equipment is intended for ordinary locations and for permanent installation into one or more Listed emergency luminaires.
18. Do not use outdoor.

► WIRING DIAGRAM

The luminaire rated data and maximum mounting height can be found as follows:

1. Determine the fixture efficacy under normal AC operation, based on fixture manufacturer published data in lumens per watt (LM/W).
2. Reference DLC QPL (www.designlights.org) and Energy Star QPL (www.energystar.gov) for rated data on fixture efficacy. If fixture is not found on DLC or Energy Star Qualified Product List, contact fixture manufacturer.
3. Multiply fixture LMW by rated output power of emergency pack. Example 'model EMUFO-25170-YYI' is $25W \times 100LMW = 2500$ Lumens



Caution: Before Installation, Make Certain The A.C. Power is Off !

STEP 1: ASSEMBLING NOTICE

- > Select a suitable location on the hangable device.
- > The Maximum weight of lighting fixture should be less than 20kg.
- > Turn off the AC power before installing.
- > Assembling the EM backup with the Safety Rope with the chain link connector.
- > Please use waterproof connectors in position AC input wire interface and Dimming wire interface for application in wet location.

STEP 2: INSTALLING

- > Install the 2pcs ring M10 Hanging Ring Bolt to the EM backup and fix it with screw.
- > Install the UFO high bay to the Hanging Ring Bolt of EM backup and tighten the screws.

STEP 3: WIRING

- > Before wiring, make sure safety rope is securely locked and make sure all the screws are tight.
- > Open the cover of junction box.
- > Select the appropriate wiring diagram to connect the emergency driver to the AC driver. For other diagrams, consult the manufacturer.
- > The voltage input to the dimmable wires (DIM+, DIM-) of emergency LED driver must less than 20Vdc.
- > Using wire nuts to cover un-used wires and make sure all connections are in accordance with the NEC and any local regulations.

STEP 4: TESTING

- > After wiring is complete, apply A.C. power. Check if the indicator light lights or not, which will indicate the battery's charging situation.
- > The battery in this unit may not be fully charged. A short-term discharge test may be conducted after the EMUFO has been charging for 1 hour.

SAVE THESE INSTRUCTIONS



THIS PRODUCT CONTAINS A RECHARGEABLE LITHIUM-ION BATTERY. THE BATTERY MUST BE RECYCLED OR DISPOSED OF PROPERLY TO PREVENT FIRE.

▶ OPERATION(INDICATORSTATUS)

Mode	Test Switch Operation	Indicator Status	Comment & Solutions
AC MODE (1)	NO Pressed	ON(no flashing)	Emergency Driver is charging
AC MODE (2)	Pressed once	2s ON and 2s OFF (slow flashing)	Emergency Driver is conducting a 30s short-term emergency test
AC MODE (3)	Pressed twice (2s) in sequence	2s ON and 2s OFF (slow flashing)	Emergency Driver is conducting a long-term emergency test until battery is fully discharged
EMERGENCY MODE (1)	NO Pressed	2s ON and 2s OFF (slow flashing)	Emergency Driver is automatically conducting a emergency until battery is fully discharged
EMERGENCY MODE (2)	Pressed once	OFF	Emergency Driver is turned off
PROBLEM	When indicator flashes (50ms) ON and (50ms) OFF fast or goes off, the emergency backup pack is abnormal. Contact the manufacturer.		

WARNING
Risk of Electric Shock



Note: Please pressed test switch of the UFO- II (in once) and make certain the Emergency Driver is turned off, before installation, maintenance, storage or shipping.

▶ Max mounting height

Model	Associated Target Luminaire	Max. mounting height
EMUFO-25170-YY	LEDSION LIGHTING LLC	29.4feet (8.96m)
EMUFO-40170-YY		

▶ SELF-DIAGNOSTIC(MAINTENANCE)

The integrated Self- Diagnostic circuitry will automatically conduct monthly 30-second and annual 90-minute tests to verify proper emergency capability per Life Safety Code requirements. NFPA 101, Life Safety Code Outlines the following schedule:

- Monthly- During AC mode, the system conducts a (30)seconds self-discharge test of the emergency led driver every 30 days. And automatically restore to normal charging after (30)seconds dis-charged.
- Annually - During AC mode, the system conducts a (90)minutes self-discharge test of the emergency led driver every 365 days. And automatically restore to normal charging after fully dis-charged.
- "Written Records of the Testing should be kept by the owner for inspection by the authority having jurisdiction." If the charging indicator is flashing rapidly or off, contact manufacturer.

▶ Pckage

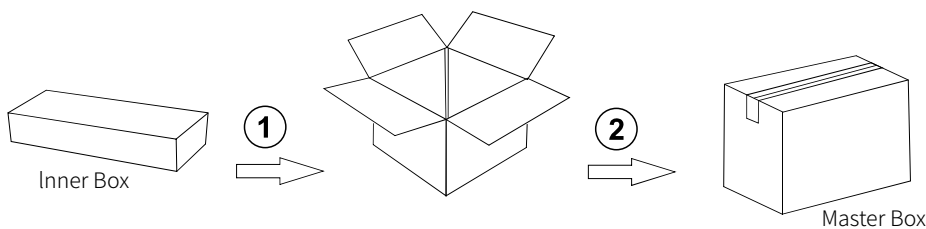

Power	Length(inch)	Width(inch)	Height(inch)	G.W(kg)	N.W(kg)	QTY(pcs)
25W	14.96"	14.96"	9.84"	9.6	6.8	4
40W	14.96"	14.96"	9.84"	10	7.2	4