



3Watts 3CCT Parking Garage LED V4



Date:..... Location:

Product:.....Project:.....

Quantity:..... Catalog#

FEATURES

- 3Watts 3CCT LED with adjustable switch inside.
- Built in Motion sensor receptacle port
- Wide beam angle with high transmission PC optics.
- Anti-corrosion and rust proof
- 50,000 hours lifetime

SUITABLE APPLICATIONS

- Shopping mall/Building/Airport Garage Parking lot lighting
- Underground Garage Parking lot lighting



CONSTRUCTION:

Heavy die-cast aluminum alloy housing bronze powder-coated finish.

ELECTRICAL:

Available as 120-277V input. -20°C to 45°C.

OPTICAL SYSTEM:

Lumileds 2835LED chips. High quality light transmission PC optics.150° beam angle.

INSTALLATION&MOUNTING:

Ceiling mount or 3/4" thread conduit entry on top or side for pendant mounting (pendant provided by others)

WARRANTY:

5-year limited warranty. Actual performance may differ as a result of end-user environment and application.

PERFORMANCE :

LS-4NCP80/60/40W-H-TX(XX)-Y

Wattage	Power Factor	Motion Detection	Voltage/CurrentInput		Light Efficiency	CCT tunable
			120V	277V		
40W	0.9	40FT	0.33A	0.14A	130LM/W	3500K/4000K/5000K
60W	0.9	40FT	0.50A	0.21A	130LM/W	3500K/4000K/5000K
80W	0.9	40FT	0.66A	0.28A	130LM/W	3500K/4000K/5000K

Motion Sensor Compatible



HD07VR-MH Occupancy sensor plug & play

CCT&Power Adjustable

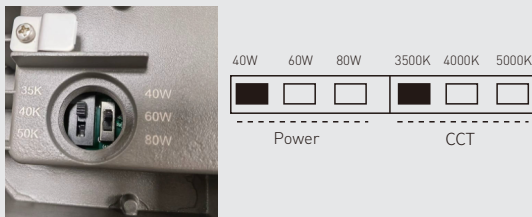

The lamps have the function of adjusting power and color temperature

PRODUCT ORDERING GUIDE

LS-4NCP80/60/40W-H-TX(XX)-Y
1 2 3 4 5 6
 LS - 4NCP 80/60/40W - H - TX(XX) - Y

LS LEDSION

4NCP G4 New canopy

Power Tunable

80W Power 80W 60W Power 60W

40W Power 40W

H/L High/Low Light Efficiency

TX(XX):CCT Tunable

35K CCT:3500K

40K CCT:4000K

50K CCT:5000K

Y YES Motion Sensor

N NO Motion Sensor

Electric Characteristic

Specification/Model	LS-4NCP80/60/40W-H-TX(XX)-Y	LS-4NCP80/60/40W-H-TX(XX)-Y	LS-4NCP80/60/40W-H-TX(XX)-Y
LED Driver	UL listed WEPOWERLED Brand 0-10V Dimmable		
Input power	80W	60W	40W
Lumens output	10400LM	7800LM	5200LM
Light Efficiency	130LM/W	130LM/W	130LM/W
CRI	>80	>80	>80
Color Temperature	5000K	5000K	5000K
Input voltage	120-277V/AC	120-277V/AC	120-277V/AC
Light distribution type	150D	150D	150D
Working temperature	-20+45°C	-20+45°C	-20+45°C
Junction temperature	<75°C	<75°C	<75°C
Lamp Efficiency	≥90%	≥90%	≥90%
Certificate	UL CUL DLC	UL CUL DLC	UL CUL DLC
Equivalent	180-250WMH/HP S	120-180WMH/HP S	80-120WMH/HP S

DIMENSION

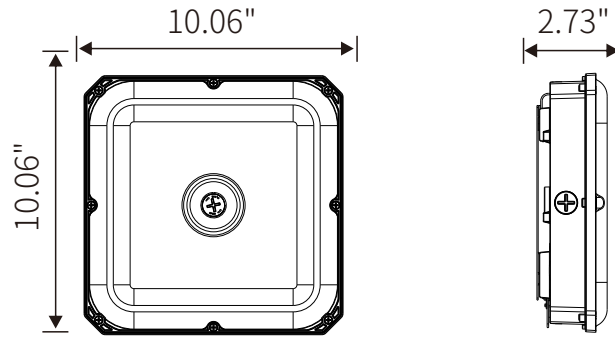

DISTRIBUTION DIAGRAM

LS-4NCP80/60/40W-H-TX(XX)-Y

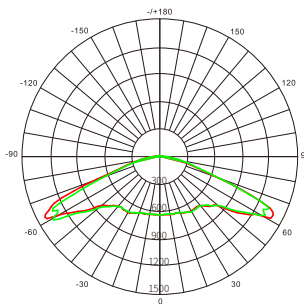

AVERAGE BEAM ANGLE(50%): 150°
 UNIT:CD
 Lumens:5200LM
 Test Number:40W
 Test Number:5000K

— C0/180, 154
 — C30/210,111.5
 — C60/240,109.7
 — C90/270,154.2

LS-4NCP80/60/40W-H-TX(XX)-Y

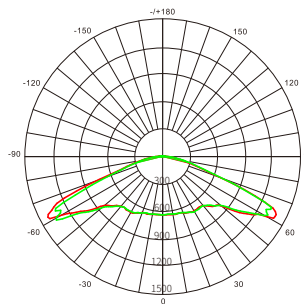

AVERAGE BEAM ANGLE(50%): 150°
 UNIT:CD
 Lumens:7800LM
 Test Number:60W
 Test Number:5000K

— C0/180, 154
 — C30/210,111.5
 — C60/240,109.7
 — C90/270,154.2

LS-4NCP80/60/40W-H-TX(XX)-Y

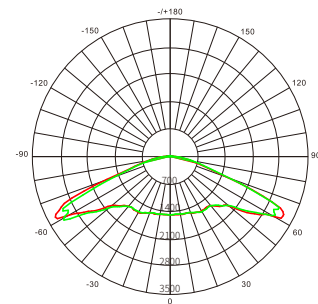

AVERAGE BEAM ANGLE(50%): 150°
 UNIT:CD
 Lumens:10400LM
 Test Number:80W
 Test Number:5000K

— C0/180, 154
 — C30/210,111.5
 — C60/240,109.7
 — C90/270,154.2

Installation

Installation method I : Ceiling Installation

1. Loosen the screw to take off the mounting plate from the lamp.

2. Screw the mounting plate to the ceiling.

connect wires with terminal caps.

Input/Dimmer	Lamp
Green	Green
White	White
Black	Black
Dim-	Pink
Dim+	

this connection can be omitted if with non-dim driver

4. Hook up lamp on the mounting plate.

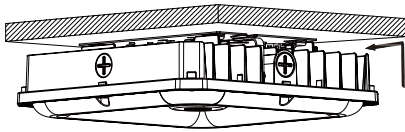

5. Secure the screw. Installation completed.

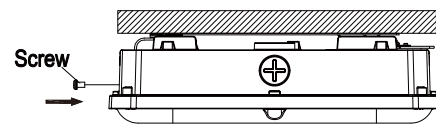

Installation method I : Ceiling Installation

1. Connecting wires with terminal caps as picture shows.

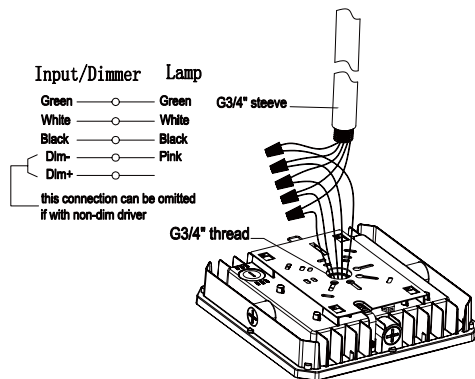

2. Rotating the steeve to make it fixed with lamp. Installation completed.

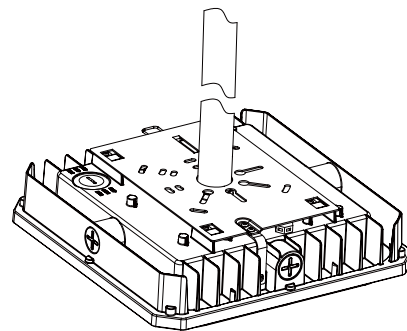

Plug sensor installation

1. Unscrew the PC cap on the lampshade counter-clockwise with a flat-head screwdriver on the lamp which already installed.

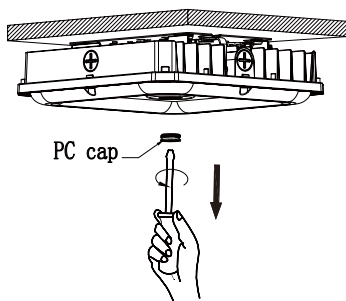

2. Screw the sensor clockwise by hands.

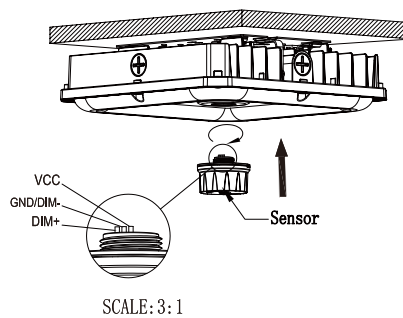

3. After tighten the sensor, Lighting the lamp, if the sensor works well, the installation finish.

