

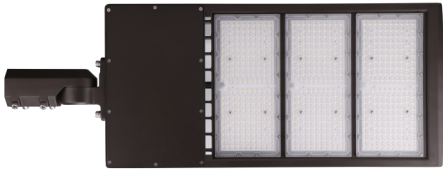

450W Parking Lot Shoebox LED light



Date:..... Location:

Product:..... Project:.....

Quantity:..... Catalog#

FEATURES

- Multiple mounts Available. Easy install
- 100-277V or 480V input voltage available.
- Low profile housing with enhanced thermal heat sink.
- 6kV built-in plus 10kV external surge protection
- 50,000hrs Life time.

SUITABLE APPLICATIONS

- Warehouses
- Stadiums
- Factories
- Parking Lots
- Shopping Malls
- Supermarkets
- Logistic Centers
- Auto dealerships

CONSTRUCTION:

Heavy die-cast aluminum alloy housing with bronze powder-coated finish.

ELECTRICAL:

Available as 120-277V or 480V input. -20°C to 45°C,

OPTICAL SYSTEM:

High brightness lumileds LED chips.
Special PC lens with TYPE III and TYPE V distribution

INSTALLATION&MOUNTING:

Wall Mounting/Pole Mounting with Different Mount bracket for easy installation.

WARRANTY:

5-year limited warranty. Actual performance may differ as a result of end-user environment application.

CONTROLS&DIMMING

0-10V dimming comes standard.

PERFORMANCE

Model NO	Wattage	Viewing Angle	Voltage/Current Input		Light Efficiency	Kelvin Options
			120V	277V		
LS-ESBV7E450WAT3A1-abcdefg	450W	Type III	3.75A	1.62A	130LM/W	30K/40K/50K

Model NO	Wattage	Viewing Angle	Voltage/Current Input		Light Efficiency	Kelvin Options
			347V	480V		
LS-ESBV7E450WAT3H1-abcdefg	450W	Type III	1.29A	0.93A	130LM/W	30K/40K/50K

➤ Electric Characteristic

Specification/Model	LS-ESBV7E450WAT3A1-abcdefg	
LED Driver	UL listed LED DRIVER 0-10V Dimmable	
Input power	450W	450W
Lumens output	58500LM	58500LM
Efficiency	130LM/W	130LM/W
CRI	>82	>82
Color Temperature	5000K	5000K
Input voltage	120-277V/AC	277-480V/AC
Light distribution type	TYPE III	TYPE III
Working temperature	-20+45°C	-20+45°C
Junction temperature	<75°C	<75°C
lamps efficiency	≥90%	≥90%
Certificate	UL CUL DLC	UL CUL DLC
Equivalent	1000-1500W MH/HPS	1000-1500WMH/HPS

➤ Electric Characteristic

PRODUCT ORDERING GUIDE

LS-ESBV7E450WAT3A1-abcdefg

1 2 3 4 5

[LS] - [ESBV7] E [450W] A [T3] [A1] abcdefg

- LS Factory code
- ESBV7 V7 Shoebox
- 450W Power T3 Light distribution type
- A1 Input voltage 120-277V/AC
- H1 Input voltage 277-480V/AC

Optional Mount Bracket:



AM Slipfitter Mount



DM Direct Mount



YM Yoke Mount

Optional Functions:

Photocell sensor options

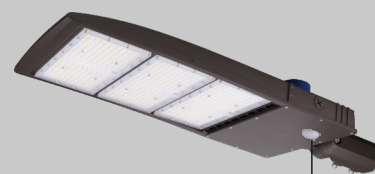
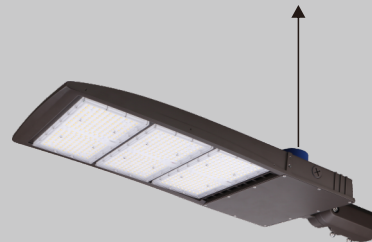

Occupancy sensor options

DIMENSION

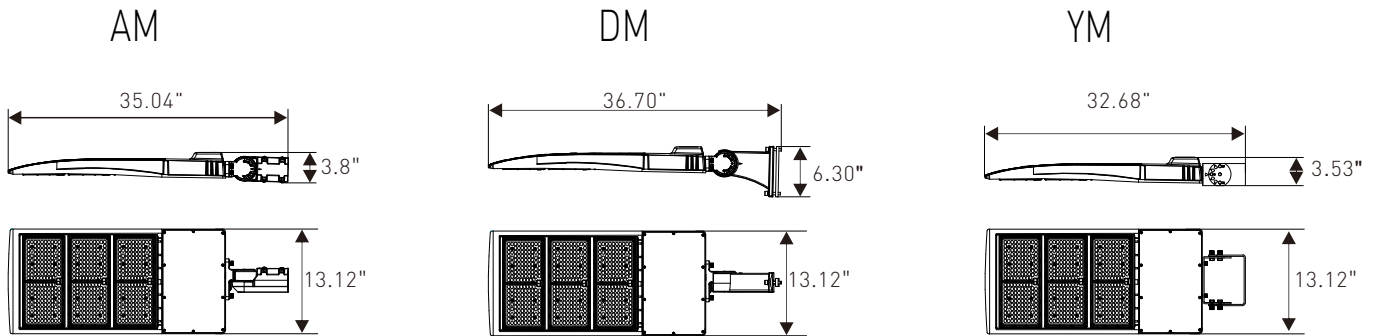

DISTRIBUTION DIAGRAM

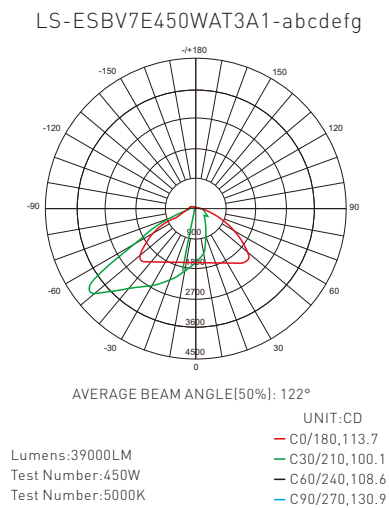

Installation

1.ADJUSTABLE FITTER MoUNTING (AM)

Step 1: Loosen the four bolts on AM bracket, connect the wires correctly, and pull the wires into the poles.(Figure 1)

Step 2: Place the bracket into the pole and lock the four bolts.(Figure 2)

Notice: Adjustable angle is 0-90°(Figure 1)

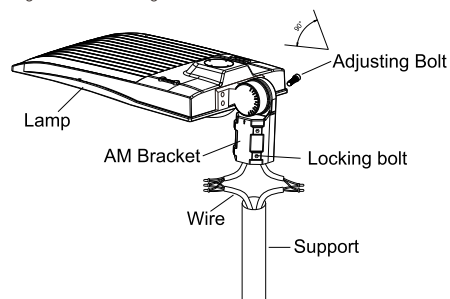

Figure 1

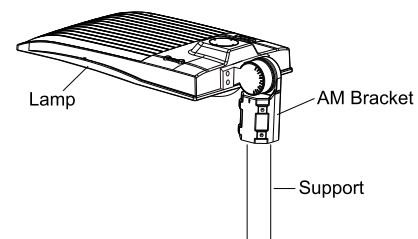

Figure 2

2. DIRECT MOUNTING (DM)

Step 1: Fix DM bracket to square pole with bolt, open the side lid of DM bracket, pull the wire into junction box, and connect the wire correctly. (Figure 3)

Step 2: Put the connected wire into the junction box, then cover the junction box. (Figure 4)

Notice: Adjustable angle is 0-35° (Figure 3).

Same as round pole installation, please remember to remove the silicon plate when install the fixture in round pole (Figure 5)

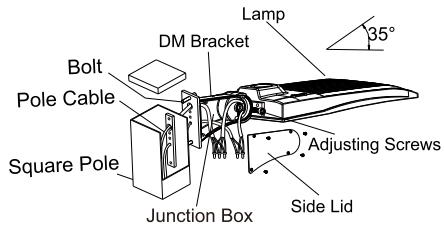

Figure 3

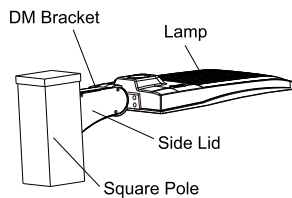

Figure 4

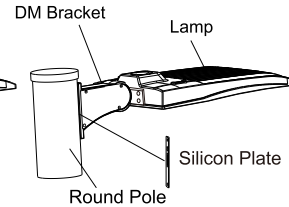

Figure 5

3. YOKE MOUNTING (YM)

Step 1: Drill holes on the wall as shown. (Figure 6)

Step 2: Knock the expansion bolts into the wall. (Figure 7)

Step 3: Connect the fixture to the bracket and tighten the screws; connect the wires properly and put them into junction box. (Figure 8)

Notice: Adjustable angle is 0-90° (Figure 8)

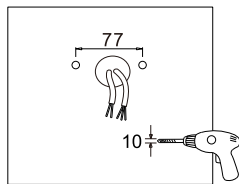

Figure 6

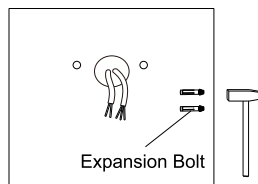

Figure 7

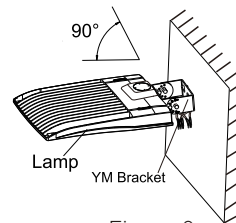

Figure 8