

Englander[®]

PELLETSTOVES

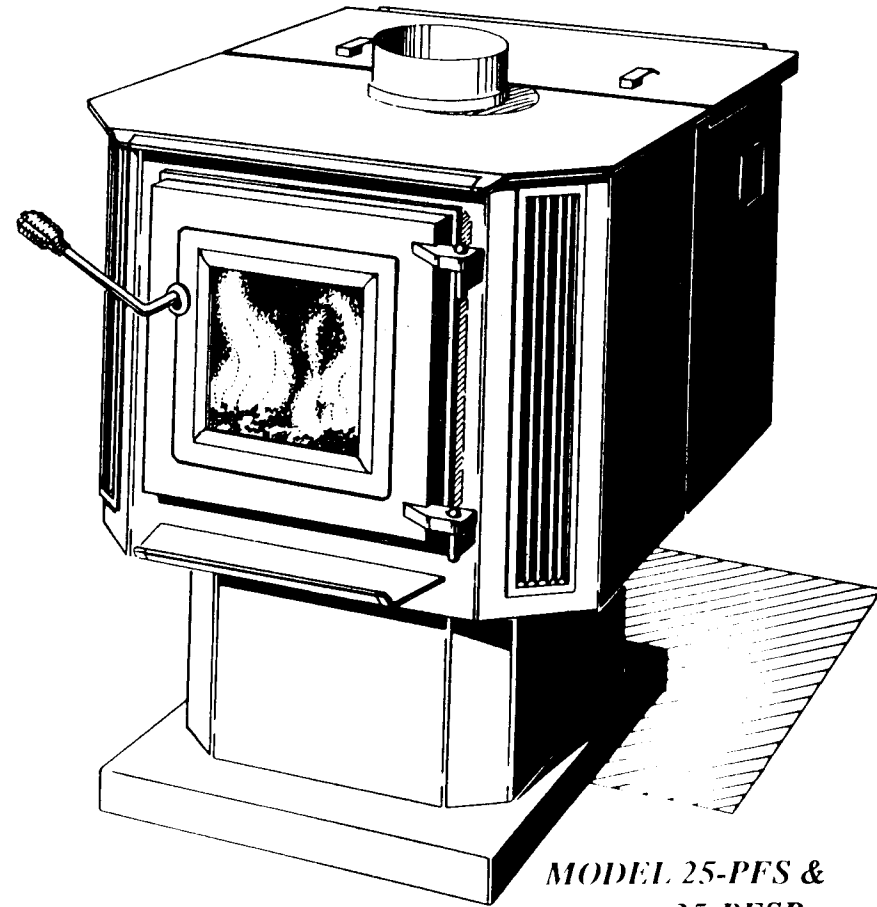

*MODEL 25-PFS &
25-PFSP*

England Stove Works, Inc.

P. O. Box 206
Mornoe, VA 24574
Phone 804-929-0120
Fax 804-929-4810

SAFETY NOTICE:

IF THIS ENGLANDER STOVE IS NOT PROPERLY INSTALLED, A HOUSE FIRE MAY RESULT. FOR YOUR SAFETY, FOLLOW THE INSTALLATION DIRECTIONS. CONTACT LOCAL BUILDING OR FIRE OFFICIALS ABOUT RESTRICTIONS AND INSTALLATION INSPECTIONS IN YOUR AREA.

Thank you for purchasing an Englander product from a fine line of heating equipment. Each Englander unit is constructed of the highest quality material and built by craftsmen who truly take pride in their workmanship. Please read this manual before attempting to move or install your unit. The unit you have purchased is a new generation wood heating appliance, so proper installation is of utmost importance. We at Englander wish you many years of safe heating pleasure with your new Englander heating appliance.

CAUTION: This unit must be installed in accordance with these instructions and must comply with local building and fire codes. Failure to do so could result in a chimney, house fire or smoke damage. Keep children, furniture, fixtures and all combustibles far away from any Englander appliance.

Maintain a minimum clearance of 18" from front of the fire box (4 inches on either side of the door), 3" from flue pipe, 6 inches on the sides of the fire box and one inch from the hopper to any combustible.

READ THESE INSTRUCTIONS CAREFULLY BEFORE INSTALLING THIS MODEL.

The 25-PFS & 25-PFSP is approved for mobile home installation with outside combustion air hook-up. Your mobile home unit must have the combustion air intake extend to the exterior of the home, with the use of a 2-inch ABS pipe coupling and the 2-inch ABS-DBW pipe to extend through the floor or wall. See Section I in this manual for flue hook-up.

SAFETY NOTICE:

IF THIS ENGLANDER STOVE IS NOT PROPERLY INSTALLED, A HOUSE FIRE MAY RESULT. FOR YOUR SAFETY, FOLLOW THE INSTALLATION INSTRUCTIONS. CONTACT LOCAL BUILDING OR FIRE OFFICIALS ABOUT RESTRICTIONS AND INSTALLATION INSPECTIONS IN YOUR AREA.

Englander Stove Works, Inc.

P. O. Box 206
 Monroe, VA. 24572
 Phone: 804-929-0120
 Fax: 804-929-4810

INSTALLATION & OPERATION MANUAL

Appendix

Section I--Flue System for 25-PFS & 25-PFSP.....	2
A. Existing Flue System.....	2
B. Flue Size Needed.....	2
C. Installation of a New Flue System.....	2-3
Section II--Unit Preparation.....	3-4
Section III--Floor & Wall Protection for 25-PFS & 25-PFSP.....	4-5
A. Floor Protection.....	4
B. Wall Protection.....	5
Section IV--Freestanding Placement & Hook-Up.....	5
Section V--Accessory Items.....	5-6
Section VI--Operating Instructions.....	6-13
General.....	6
The Horizontal Feed System.....	7
On Button.....	7
Off Button.....	7
Heat Control Knob.....	7
Blower Speed Knob.....	7
Start-Up Procedures.....	8
First Fire.....	8
Shutdown Procedure.....	9
Daily Operation.....	9
Ash Removal and Disposal.....	9-10
Maintenance.....	10
Burn Pot.....	10
Auger Bearings.....	10-11
Auger and Shaft.....	11
Electrical Motors.....	11-12
Control Board.....	12
Gaskets.....	12
Finish.....	12
External Thermostat.....	13
Warranty Information.....	13-14
25-PFS & 25-PFSP Replacement Parts List.....	14
25-PFS & 25-PFSP Installation Diagram (Masonry Chimney).....	15
25-PFS & 25-PFSP Installation.....	16
25-PFS Parts Diagram.....	17
Pellet Unit Wiring Diagram for 25-PFS.....	18
25-PFSP Parts Diagram.....	19
Pellet Unit Wiring Diagram for 25-PFSP.....	20

SECTION I: FLUE SYSTEM FOR 25-PFS & 25-PFSP

A. Existing Flue System

The 25-PFS & 25-PFSP is designed to connect to an existing flue system, such as masonry or premanufactured Class A flue systems. If you have a masonry flue system you should inspect the inner liner very carefully for cracks in the liner. If you have an existing premanufactured flue system you should inspect the inner liner to insure there is no buckling or warping and no cracks in the liner. Whether you have a masonry or premanufactured flue system, you should clean the chimney before installing your new unit to the flue system. We strongly recommend you have a qualified chimney sweep clean and inspect your flue system. The sweep can spot problems you may unknowingly overlook. The sweep in most cases will be able to make the necessary repairs or at least recommend qualified people to do the work.

B. Flue Size Needed:

The proper flue size is determined by measuring the inside diameter or the flue collar on the unit. The 25-PFS & 25-PFSP is equipped with a six inch (6") TOP EXHAUST FLUE COLLAR. Therefore, the connector pipe should be six inches (6") or larger and never less in diameter than the flue collar on the stove. The area of the chimney liner must also be equal to or greater than the area of the flue collar on the stove. Connector pipe should be 24 gauge steel and 14 inches from combustible wall or ceiling.

C. Installation of A New Flue System

Masonry flue: In the event you plan to install either a flue system yourself or have a flue system installed, there are several avenues you can take. In the mid and late seventies masonry flue systems became very popular. Even today a masonry flue system is a satisfactory system to have. If you are considering a masonry system, you should consult with your local building officials for the proper procedures in construction of a masonry flue system. We recommend you consult with and have your flue built by a licensed, bonded contractor. Most masonry flues are placed against the outside wall and extend upward beside the house. The flue thimble is then inserted through the wall, making connection with the vertical flue and the stove flue pipe. Exercise extreme caution when drilling through the wall. You must maintain proper clearance between the connecting liner and any combustibles in the wall. We also recommend that you have a flue door located at least 2 feet below your flue thimble connection for easy access and clean out. You should make this door as airtight as possible. It is the customer's responsibility to insure that the chimney (or flue system) is safe and in good operating condition. England's Stove Works, Inc. will not be responsible for an accident contributed to a unit connected to a faulty chimney or flue system.

Premanufactured Flue System: In the past few years premanufactured flue systems have become very popular, because this type system is fairly easy to install and when installed correctly, it is very safe. There are many premanufactured flue systems on the market to choose from. In making your choice be sure the system has a recognized label of approval such as U.L., B.O.C.A. or I.C.B.O. Any of these approvals will insure the flue system is constructed of the proper materials and meets required safety standards. Your local Englander dealer will usually handle a top grade and approved flue system. There are two very popular methods for installation of a premanufactured flue system. The first, most popular is through the ceiling and out the roof. This is the most direct route and offers the least amount of restrictions. Single wall 24 gauge or thicker pipe is used from the ceiling to the unit and class "A" insulated pipe is used from the ceiling through the roof. The second method for installation of a premanufactured system is to go through the wall. Single wall 24 gauge or thicker pipe is used from the wall to the unit and class "A" insulated pipe through the wall. Whether you choose to go through the ceiling or through the wall, you must exercise extreme caution in your installation.

You must maintain proper clearances to combustibles in either installation. Your flue pipe manufacturer furnished a wall thimble or ceiling support box, and when these are installed properly the correct safety clearances will be met. If you choose a premanufactured flue system and you feel you are not qualified or capable of installing the system, you can consult your local Englander dealer for information or a qualified contractor can install the system for you. It is the customer's responsibility to insure that the chimney (or flue system) is safe and in good operating condition. England's Stove Works, Inc. will not be responsible for an accident contributed to a unit connected to a faulty chimney or flue system.

SECTION II: UNIT PREPARATION

Most dealers will prepare your unit for operation and even dry run the unit for at least thirty minutes before delivery. However, in the event this has not been done, follow these steps to prepare your unit for operation.

1. Open the hopper lid and remove the following contents:
 - A. Six inch flue collar
 - B. Two hopper lid latches
 - C. AC-SH spring handle for door
2. Attach the six inch flue collar to the six inch opening on the top of the firebox and fasten down tight.
3. Attach the AC-SH spring handle to the door handle.

4. Attach the hopper lid latch handles to the hopper (see the diagram in this manual).
5. Remove the back hopper cover plate from the back side of the hopper. (Loosen the four screws and let the cover plate slide straight down.)
6. Check to insure that all the wires are clear of the fan blades on the two auger motors. Check to insure that the fan blades are not broken or jammed against the auger motor bearing.
7. Plug the unit into a 110 outlet, then press the green ON button (located on the control panel on the right side of the hopper) a green light on the button will illuminate. The bottom auger will start to operate and the top auger will begin to operate intermediately. The combustion blower will begin to operate. Turn the top control knob on the control panel to the high setting. The top auger motor will operate more often and for a longer period of time. Turn the top knob on the control panel to low and the top auger should stay on for a very short time. To observe the top auger open the hopper lid and look down in the bottom of the hopper. To observe the bottom auger, open the door and look down in the burn pot. If you have a problem, unplug the unit and contact your dealer as soon as possible or call customer service at 804-929-0120.

Note: The second knob from the top operates the convection blowers. These blowers will not operate until the unit has been fired and the temperature in the heat chamber reaches 135F. See Start-Up.

SECTION III: FLOOR AND WALL PROTECTION FOR 25-PFS & 25-PFSP

A. Floor Protection

If your floor is constructed of a non-combustible material such as brick or concrete then there is no floor protection required or needed. If your floor is constructed of a combustible material such as hardwood, carpet or linoleum, you must place protection between the unit and the combustible material. There are many stove floor and wall boards on the market. One must be very cautious in choosing the proper protection. The board must be U.L. listed. After examining the area in which you plan to locate your unit and you determine it requires a board, the next step is to select the proper size board needed. The Englander unit you choose will determine the board size. The approved protector board should be large enough to provide a minimum of 3" behind the unit and 3" on either side, with 6" in the front or the side where the door is located. The 25-PFS requires a minimum 36"x36" floor protector.

B. Wall Protection

The 25-PFS & 25-PFSP can be placed within 1" of a combustible wall such as paneling, wall paper or sheet rock from the rear and sides of the hopper and 6" from the sides of the firebox. With such a close clearance to combustibles, additional wall protection is usually not necessary.

SECTION IV: FREESTANDING PLACEMENT AND HOOK-UP

Once you have your flue system complete and you have installed your floor and wall protection, you are now ready to place your unit! The first problem you may encounter is getting the unit in your home. All Englander products are well constructed which makes them rather heavy. We recommend you borrow or rent a hand cart. As a rule three or four adults can handle any Englander product. Never try handling an Englander product by yourself!

CHIMNEY CONNECTOR

The chimney connector must be 6 inches in diameter, 24 gauge steel pipe. Do not use aluminum or galvanized steel. They cannot properly withstand the extreme temperatures of a wood pellet fire. Do not use chimney connector pipe (single wall) as a chimney. You must connect your stove to a chimney comparable to those listed in this manual (See Section I).

A chimney connector must be attached to the stove and to each other with the crimped end toward the stove. All joints should be mortared with furnace cement and secured with three sheet metal screws. For proper operation, the chimney connector should be as short as possible. Horizontal lengths of chimney connector should have an upward slope from the stove of 1/4 inch per ft. Maintain 18 inch clearances between the chimney connector and the wall and ceiling unless a wall protection system is installed. The 25-PFS & 25-PFSP is a pressurized system so it is very important to insure the flue system does not leak.

SECTION V: ACCESSORY ITEMS

There are several accessory items available for your 25-PFS & 25-PFSP. It is suggested that you install any accessory items before proceeding to the next section. However, Englander accessories are designed to be add-on items at any time. If you purchase accessories after you have purchased your unit, simply let the unit cool down and add your accessories as follows:

AC-101-PU Brass Trim

There are two pieces of J-Channel Trim in this kit that snap on to the edges of the stove. The top front edge and the ash apron front edge. Remove the protective plastic film, start at one end of the piece and peel off the film. The pieces are precut to fit the edges so match the piece up with the proper edge, center the channel on the proper edge and with the short side of the J-Channel down force the under side of the J-Channel over the edge of the metal. If the J-Channel is too tight get it started by hand then lightly tap into place with a wooden block or the wooden end of a hammer. If the J-Channel is too loose and will not stay in place, lay the long side of the J-Channel down on a flat surface and bend (crimp) the short side in on each end and in the center slightly. Follow this procedure with each piece.

AC-02 Brass Rail

This accessory is mounted on a metal base and simply sits on top of the stove.

AC-106-P Brass Window Trim

With the door closed, take the spring clip which has a tee on one end and twist into the groove on the back side of the AC-106-P allowing the plain end of the spring to fall into the groove. You can place the spring clip on any side of the AC-106-P, however, the side of the AC-106-P that will be placed toward the bottom of the door is best. Hold the spring clip in place and slide the bottom edge of the AC-106-P on to the bottom ledge of the window opening. Now with both hands, press down and in, pushing the AC-106-P in place. Press all four corners firmly in to insure they are in the window opening as far as they will go. We suggest you place furnace cement in each corner on the back side of the AC-106-P. This will insure the trim stays in place when the door is being opened and closed.

SECTION VI: OPERATING INSTRUCTIONS

General

The 25-PFS & 25-PFSP has an induced draft system and will not operate on natural draft. It is designed for continuous operation. Frequent shutdown is not normally required. The control board permits the stove to be operated by a time relay-delay system which allows the top auger motor to run for a desired number of seconds and shut down for a desired number of seconds. The bottom auger operates continuously. The time relay-delay system controls the heat output of the unit. Remember the 25-PFS & 25-PFSP is using solid fuel which, unlike gas or oil, does not burn instantly. It is necessary to maintain a fire at all times. Use only wood pellet fuel.

The Horizontal Feed System

The 25-PFS & 25-PFSP has a double feed auger system which consists of two augers, a top auger and a bottom auger. The top auger is driven by a 1 rpm motor and is controlled by the control board which transfers pellets from the hopper to the bottom auger. There is a 4 inch air space between the top auger and the bottom auger. The bottom auger is also driven by a 1 rpm motor and operates continuously. The bottom auger transfers the fuel to the burnpot by bringing in the fuel from the bottom and pushing it up to the burn ring. Any material in the fuel which does not burn is pushed up and out. This enables you to burn any wood pellet fuel available on the market. The bottom auger operates continuously so this insures there is no build up of fuel in the bottom auger tube, the fuel being dropped down from the top auger is quickly transferred to the burn pot where the combustion air is forced across the fuel.

On Button

This is the green button located at the bottom right side of the control panel. When this button is pressed the system is energized which is indicated by the green light illuminated on the button. See Start-Up.

Off Button

This is the red button located at the bottom right side of the control panel. When this button is pressed the unit will go into shut down mode. See Shut Down.

Heat Control Knob (Top Knob)

The heat control knob allows you to operate the 25-PFS & 25-PFSP at a wide range of heat settings and is located at the top of the control panel. The range of control is from low which will allow the unit to burn approximately 1 pound of fuel per hour to high which will allow the unit to burn approximately 7 pounds of fuel per hour. The BTU output will vary depending on the brand of fuel you are using and can range from 8,000 BTU per hour to 56,000 BTU per hour.

Blower Speed Knob

The blower speed knob controls the CFM output rate of the convection blowers. By using this control knob you can adjust the speed rate of the convection blower from off up to 280 CFM. The convection blowers will not operate when the unit is cold. The heat chamber has to reach 135F before the convection blowers will activate. See Start-Up.

Start-Up Procedures:

1. Make sure the fuel hopper is clean and free of foreign matter.
2. Plug your power cord into a 110 outlet.
3. Press the on switch (The green light should be on). The combustion blower will begin operating.
4. Set the heat control knob on the high setting and check to insure the top auger in the hopper is turning, then check the bottom auger coming into the firepot to insure it is turning. (If after 20 seconds either auger is not turning or the combustion blower is not operating, do not proceed! Call your dealer or the factory!)
5. Put about five pounds of pellet fuel into the hopper and allow the unit to run about ten minutes to insure the fuel is moving through the feed system properly.
6. Allow the fuel to build up in the burn pot to a level of one inch below the rim of the burnpot, set the heat control knob to its lowest setting, press the red off switch and fill the hopper with pellets, close the lid and make sure both lid latches are latched tight.
7. Spread a small amount of fire starter material over the top of the fuel and ignite. Close the stove door and make sure it is tight. Allow the fire starter approximately five minutes to fully ignite and turn the master switch on.

Recommended fire starting materials are: Wax impregnated wood chips, cardboard cube or liquid firestarter designed for pellet stoves. Never use kerosene, gasoline, diesel fuel or any other flammable liquids to light the stove.

8. Check to make sure the flame is sustaining itself and is increasing in intensity as it involves the fuel bed. In the unlikely event the fire goes out, check the combustion blower and the auger motors to determine that they are operating properly. Repeat steps 7 through 8.

First Fire: Allow the unit to operate in the low mode for about thirty minutes, then turn the heat range knob to the medium position about twelve o'clock. Adjust the blower speed control knob to the same position. Allow the unit to operate in this mode for approximately three hours. This will allow the unit to cure out. As the temperature in the heat chamber rises, the convection blowers will activate.

CAUTION: When firing your new unit for the first time, it is very important to burn the unit on a low or medium setting for at least three hours.

Shutdown Procedure:

Never shut the unit down by unplugging the unit from the power source. Never open the hopper lid or the firebox door without turning the power switch to OFF.

Press the OFF switch, the unit will go into the shut down mode. The instant you press the red stop button only the top auger will stop operating. The bottom auger, the combustion blower and the convection blower will continue to operate until the temperature in the fire box begins to drop. As the temperature drops to 95F the convection blowers will shut down and when the temperature drops to 90F the combustion blower and the bottom auger will shut down.

Daily Operation:

Refueling:

Always press the off button before refueling. The 25-PFS & 25-PFSP has a 50 pound hopper. When the fuel level gets down near the auger (within three to four inches) refill the hopper. Caution: the hopper lid may be warm so use well insulated gloves for hand protection, never stick your hand down near the auger while the unit is in operation.

Power Outage:

If power to the unit is interrupted for less than eighteen minutes, when the power is restored, the unit will start up and operate normally. If the power is interrupted for more than eighteen minutes, when power is restored and the heat chamber temperature is above 90F, the combustion blower and the bottom auger will activate and operate until the heat chamber cools down to below 90F. If the heat chamber is less than 90F when the power is restored, the unit will stay off.

Fire Outage:

If the fire in the burn pot should go out, the heat chamber temperature will begin to fall and any time the temperature in the heat chamber falls below 90F the unit will shut down.

Fuel Outage:

If the unit should run out of fuel or the pellet fuel should bridge in the hopper, the heat chamber temperature will begin to fall and any time the temperature in the heat chamber falls below 90F the unit will shut down.

Ash Removal and Disposal

Daily Ash Maintenance:

Every time you load fuel into the hopper, push the red button allowing the unit to burn

in the shut down mode for two minutes. Unplug the unit for the power source, quickly open the fire box door and using a long screw driver or putty knife, scrape the crust buildup in the front of the burnpot over into the firebox. Close the door, plug the back into the power source and press the green start button to restart the unit.

Weekly or Monthly Ash Removal:

When the ash buildup gets high enough that it gets within one inch of the top of burnpot, it is time for you to remove the ashes. Shut the unit down by pressing the red button and allow the unit to cool down completely. Ashes should be placed in a metal container with a tight fitting lid. The closed container of ashes should be placed on a non-combustible floor or on the ground, away from all combustible materials, pending final disposal. The ashes should be retained in the closed container until all cinders have thoroughly cooled. Once you are sure the unit is completely shut down you can use a shop vac with double filters to vacuum the ash out of the unit. There are also ash vacuums available designed for pellet units.

Maintenance:

Any time you are performing maintenance on the 25-PFS & 25-PFSP, shut the unit down, let it cool down and unplug from power source. Any maintenance performed under the hopper will require the removal of the cover plate held in place by four screws at the rear of the hopper. We recommend you use a service technician to perform service on any electrical components. Your dealer will have trained service technicians.

Burn-Pot

Inspect and clean weekly, scrape away creosote build-up and clear air holes. In the bottom of the burn pot is a burn plate that is cemented in place with high temperature cement. Holes are punched in the burn plate to allow air to flow up under the pellet fuel. Use a 1/8 drill bit to clean these holes out weekly. If you should ever need to replace the burn plate, use a large flat head screw driver and pry the plate out of the burn pot. Clean the area out under the burn plate and replace with the new burn plate using furnace cement to seal the burn plate in place.

If the burn pot ever has to be replaced, remove the hopper, the combustion blower, the auger motors, unbolt the burn pot flange from the back of the fire box and slide out through the rear of the unit. Replace the new burn pot assembly.

Auger Bearings

To replace the top auger bearing, remove the auger motor. Remove the four nuts from the bearing housing, slide the bearing and auger out of the burn pot. Loosen

the two set screws with a 9/64 Allen wrench, then slide bearing off of the auger shaft and install the new bearing assembly. Be sure to tighten the set screws. To replace the bottom auger bearing, use the same procedure as the top bearing only there is no need to remove the fuel from the hopper.

Auger and Shaft

To replace either the top or bottom auger, follow the same procedure as used in replacing the auger bearing. Be sure to tighten the set screws on the bearing block.

Electrical Motors

Convection Blowers:

The two 140 CFM convection blowers are located directly under the firebox. To remove the one or both blowers, unplug the power leads from the control panel, remove the screws holding the blower in place and slide the blower toward the rear of the stove. To install a new convection blower, slide the new blower in place and replace the screws.

Combustion Blower:

To replace the convection blower, it is not necessary to remove the blower from the burn pot altogether. You can remove the two screws which attach the motor to the blower bell housing and lift the motor and impeller out of the housing and unplug the power leads from the back of the control panel. Take the new motor and remove the motor and impeller from the bell housing in the same manner, then put that motor and impeller into the housing attached to the burn pot. Replace the screws and connect the two power leads to the control board.

Auger Motor:

To replace either the top or bottom auger, disconnect the power leads on the motor to be replaced, loosen the set bolt on the locking collar, slide the motor straight back out of the 3/4 inch auger shaft. The shaft on the auger motor has a flat side; this shaft slides into the 3/4 inch auger shaft. Make sure the shaft on the auger motor is turned so the locking bolt will tighten against the flat side of the shaft on the auger motor shaft.

The above electrical motors have bearings that do not require oiling.

Annual Firebox Cleaning:

Shut the unit down and allow to completely cool, then unplug the unit from its power source. There are three baffle plates located in the firebox of the unit. Remove the

top baffle plate by sliding the baffle back and allowing the front of the baffle to drop down. Removing the top baffle will expose the top heat exchanger tubes. The right and left side baffles attach to the side heat exchanger tubes with an angle iron bracket. While picking straight up on the baffle plate, pull the plate forward and remove from the unit. All the heat exchanger tubes should be exposed. Use a vacuum and remove all the ash build up on the exchanger tubes and in the firebox. At the bottom left rear in the firebox, you will notice a rectangle hole, be sure to clean the hole out. After you have cleaned the unit, replace the two side baffles and the top baffle.

Control Board

To replace the control board, unplug the power cord from the power supply, disconnect all leads from the back side of the control panel, remove the two screws holding the control panel in place. The control panel and bracket will come out. Do not try to remove the buttons or knobs, the replacement board will include new brackets and knobs. To replace the new board, connect all leads using the wiring diagram and remount the board.

Gaskets

Each unit comes with a gasket kit around the door. This gasket should be replaced every two years. To replace, pull old gasket from channel frame by using a flathead screw driver to scrape the gasket and cement from the channel frame. Place the new gasket in the frame and allow the adhesive to set up 24 hours before building a fire. If you have glass in your door, it may be necessary to replace the window gasket. However, this gasket will only have to be replaced if you remove your glass. To replace, remove glass from door. Pull old gasket off and scrape off old adhesive. The AC-GGK Glass Gasket Kit has adhesive side on the edge of the glass. Start at one corner and go all the way around the outer perimeter of the door gasket kit for your 25-PFS & 25-PFSP is AC-DGKC and the replacement window gasket is AC-GGK. Both can be purchased through your local Englander Dealer or ordered direct from the factory.

Finish (Part #AC-MCSP)

Your Englander product has been painted with 1200F Metallic Charcoal Paint which will retain its original look for several years. However, if your unit should get wet, rust spots might appear. Use steel wool to remove the rust and repaint the area with Englander AC-MCSP. When you repaint, use only Englander paint because other paints may not adhere to the Englander paint. You can purchase Englander paint from your local Englander Dealer or direct from the factory.

External Thermostat

You can use an external thermostat with any Englander pellet unit. Make sure you unplug the pellet unit from its power source.

On the back of the board is a blue, two-sided connector with a jumper wire connecting the two connectors. (See the wiring diagram.) Loosen the two screws and remove the jumper wire. Using a standard wall thermostat with two lead wires connected to the thermostat at one end, connect the two wires at the other end to the connector on the back of the board where you just removed the jumper wire and tighten the screws.

Once you have installed an external thermostat the system will operate differently. The combustion blower and auger motors will only operate in the low mode when the external thermostat is not calling for heat but when the external thermostat is calling for heat, the combustion blower and the auger motors will operate at the setting that the heat range knob is adjusted to. For example, if the heat range knob is set on medium when the external thermostat calls for heat, the unit will go from low to medium and operate at medium until the external thermostat is no longer calling for heat and then the unit will go back to the low mode. The convection blowers will not operate at all until the external thermostat calls for heat, then they will operate at the blower speed setting on the control board same as the combustion blower and auger motors. If the temperature in the heat chamber is not above 135F when the external thermostat calls for heat, then the convection blowers will not run until the heat chamber reaches 135F. After the external thermostat is no longer calling for heat, then the combustion blower and the augers will drop back to the low mode and the convection blowers will continue to run until the heat chamber temperature drops to 95F. Then the convection blowers will shut down. The use of an external thermostat is a good way to conserve fuel and insure steady even heat throughout the heating area.

When starting a pellet unit using an external thermostat, it is a good idea to set the external thermostat to its highest setting which will enable the unit to be operated in a higher mode setting. This will get fuel to the burn pot faster and get the unit hotter faster. After the unit is heated up, reset the external thermostat to the desired setting.

LIMITED 5-YEAR WARRANTY

England Stove Works extends the following warranties for our products to the original owner:

1. Carbon steel and welded seams in the firebox are warranted against extreme warpage, and welded seams from splitting to the original owner for five years.
2. Cast iron door (or doors), door hinges and hasp, are warranted against extreme warpage and cracking to the original owner for five years.
3. Component parts such as baffle plates, auger burnpot, auger screw, auger bearing, hopper and fasteners are warranted three years from the date of purchase against extreme warpage, cracking, breakage and welded seams separating.
4. Electrical components, accessory items, glass and the painted surface on the unit are warranted for one year from the date of purchase. This warranty does not apply if damage occurs because of accident, improper handling, improper operation, shipping damage, abuse, or unauthorized repair, made or attempted to be made. Purchaser must give notice of claim of defect within warranty period and pay transportation expense to and from a service center designated by the factory for service. Only units and component parts that prove to be defective will be repaired or replaced. Warranty service will be performed at our option by the dealer from whom the stove was purchased or at the factory. All liability for any consequential damages for breach of any written or implied warranty is disclaimed and excluded herefrom. Some states do not allow the exclusion or limitations of incidental or consequential damages, so the above limitations or exclusion may not apply to you. This warranty gives you specific legal rights, and you may also have other rights which vary from state to state. This warranty is void if you do not return the attached card within 10 days of the date of purchase.

25-PFS and 25-PFSP REPLACEMENT PARTS LIST

AC-DCKC	Door Gasket Kit
*AC-112	Brass Louvers
AC-G9	9"x9" Glass with gasket
AC-SH	Spring Handle
AC-MCSP	Hi-Temp Metallic Charcoal Paint
PU-047040	1 rpm Auger Motor for top auger and bottom auger
PU-BP92	Burn Pot
PU-4C440	Combustion Blower Motor
PU-4C442	140 CFM Convection Blower
PU-AF6T	Top Auger
PU-AF13B	Bottom Auger
PU-HPR92	Hopper Assembly
PU-130-50	Hopper Lid Latch
PU-UCF204-12	Auger Bearing
PU-2X570	3/4 ID Locking Collar
PU-CB92	Control Board with Bracket and Control Knobs

*25-PFS only

All replacement parts can be ordered from your local Englander dealer or from the factory.

INSTALLATION OF 25-PFS USING A MASONRY CHIMNEY

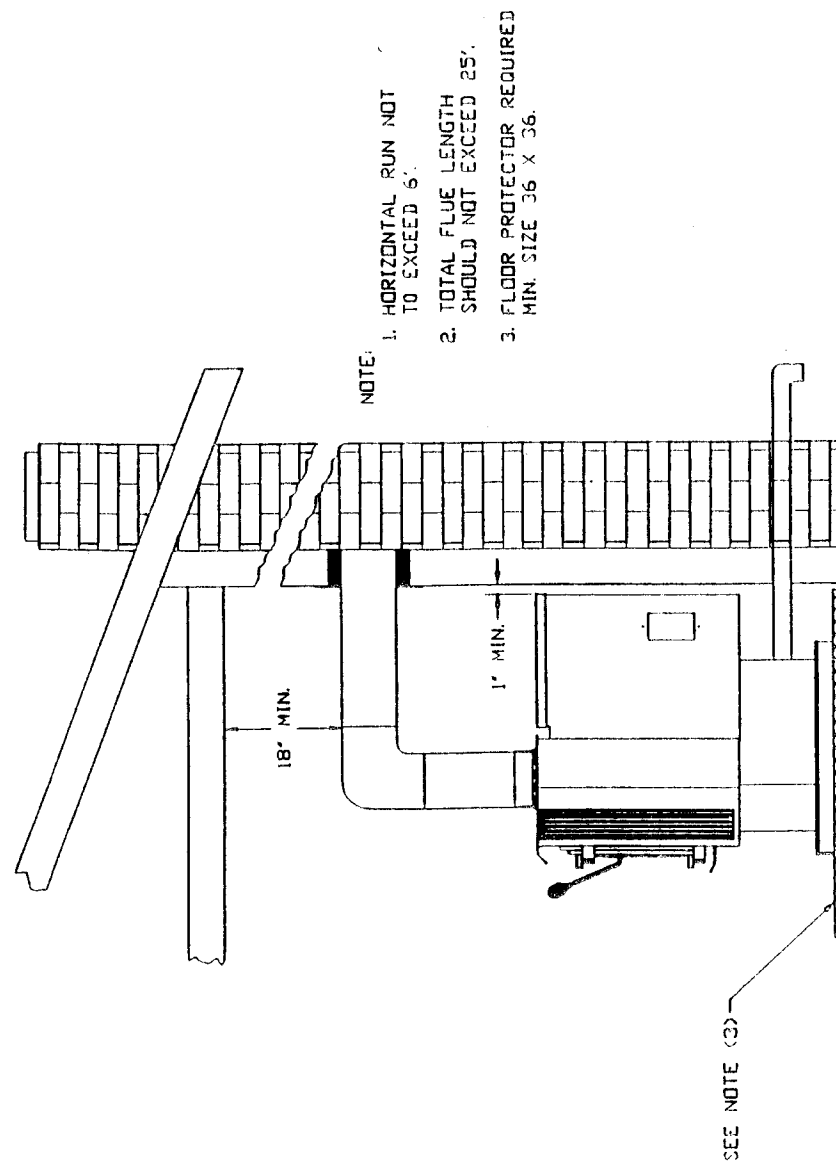

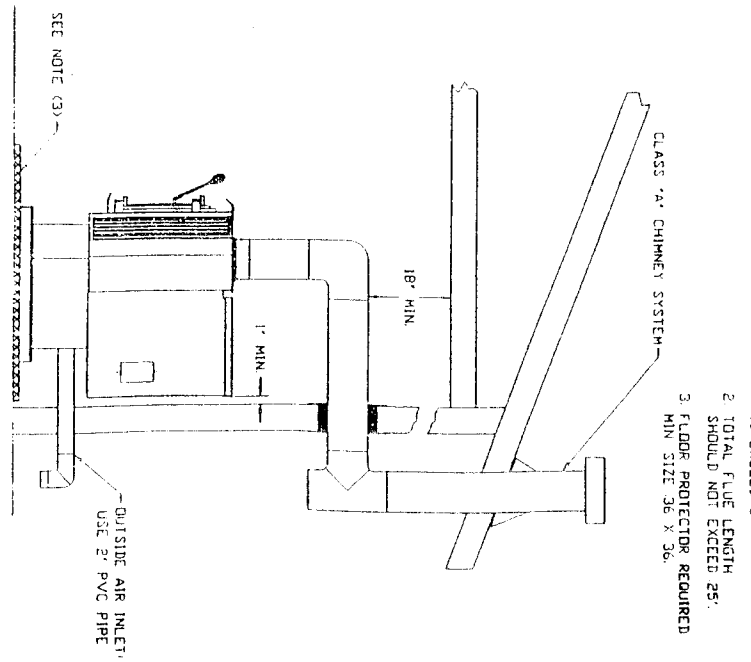
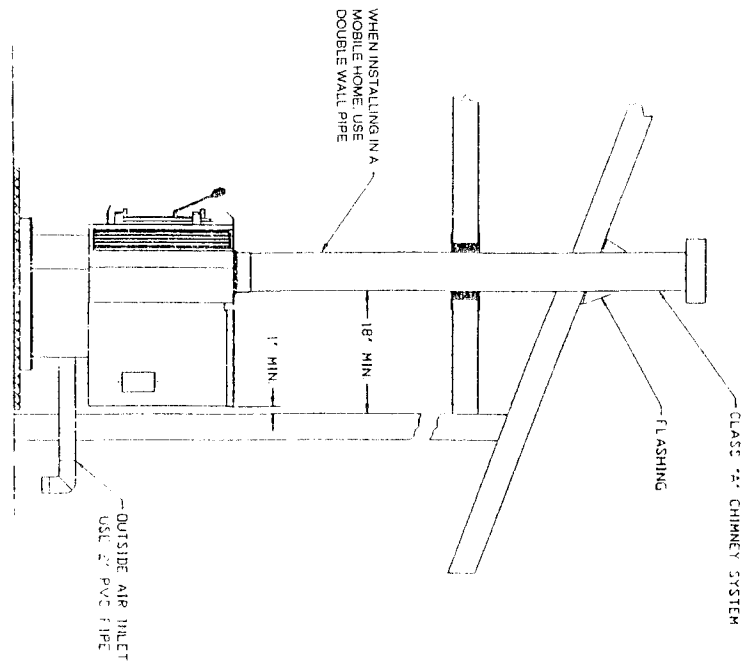

25-PFS INSTALLATION

NOTE:

- 1. HORIZONTAL RUN NOT TO EXCEED 6'
- 2. TOTAL FLUE LENGTH SHOULD NOT EXCEED 25'
- 3. FLOOR PROTECTOR REQUIRED MIN SIZE 36" X 36"

25-PFS PARTS DIAGRAM

KEY NO.	PART DESCRIPTION	PART NO.
1	AUGER OUTTOP	PU-047040
2	COLLAR AND BOLT	PU-215172
3	AUGER BEARING	PU-062204-12
4	LOWER AUGER	PU-04F10B
5	INLET AIR TUBE	5U-14C140
6	COMBUSTION BLOWER	5U-14C140
7	ACCESS PANEL FOR TOVE BACK	
8	PELLET TOPPER	
9	UPPER AUGER	2U-4162
10	BURNPOT	PU-3892
11	LEFT SIDE BLOWER FROM BACK	PU-4C112
12	RIGHT SIDE BLOWER FROM BACK	PU-4C148
13	FLUE COLLAR	CA-20
14	BRASS VENT	AC-112
15	DOOR	CA-19A

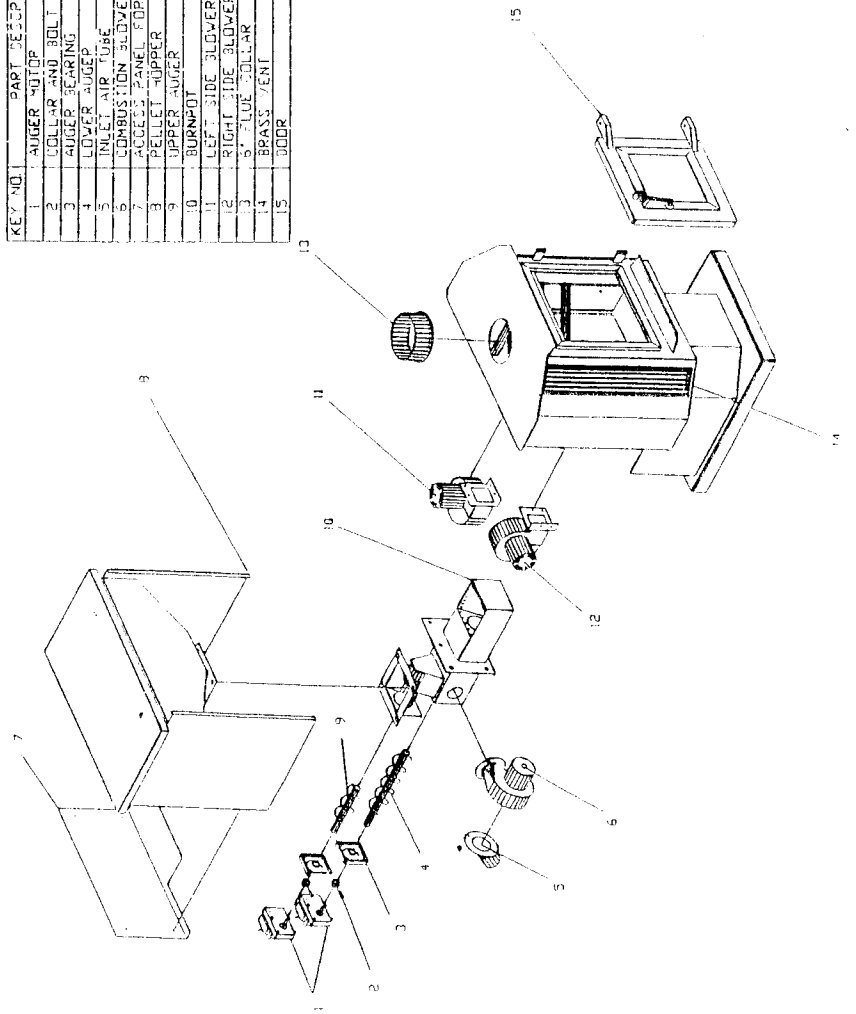

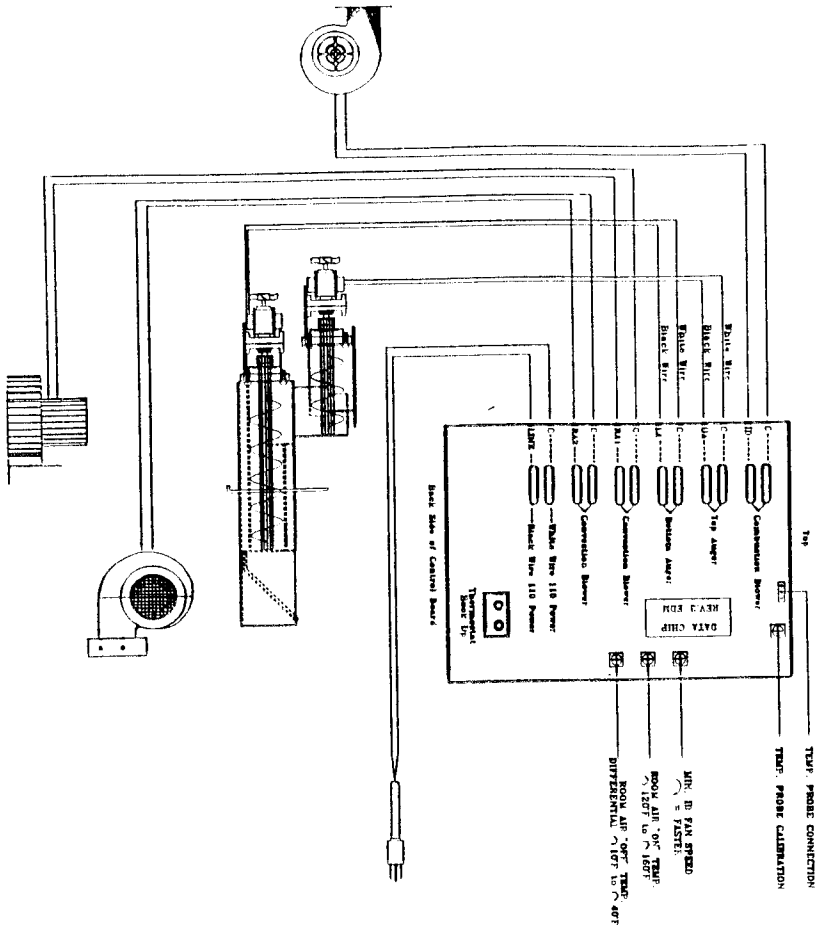

Pellet Unit Wiring Diagram
for 25-PPS

EXPLODED PARTS DIAGRAM

KEY NO.	PART DESCRIPTION	PART NO.
1	AUGER MOTOR	PU-047040
2	BOLT AND BOLT	PU-2X500
3	AUGER BEARING	PU-05204-12
4	LOWER AUGER	PU-21138
5	SLIP AIR TUBE	PU-01140
6	COMBUSTION BLOWER	PU-01140
7	ACCESS PANEL FOR TUBE BACK	
8	BELL-TOPPER	
9	UPPER AUGER	PU-04751
10	BURNPOI	PU-3393
11	SIGHT TUBE GEN-ROOM BASK	PU-21420
12	PIPE COLL-R	PU-21420
13	DOOR	PU-21420

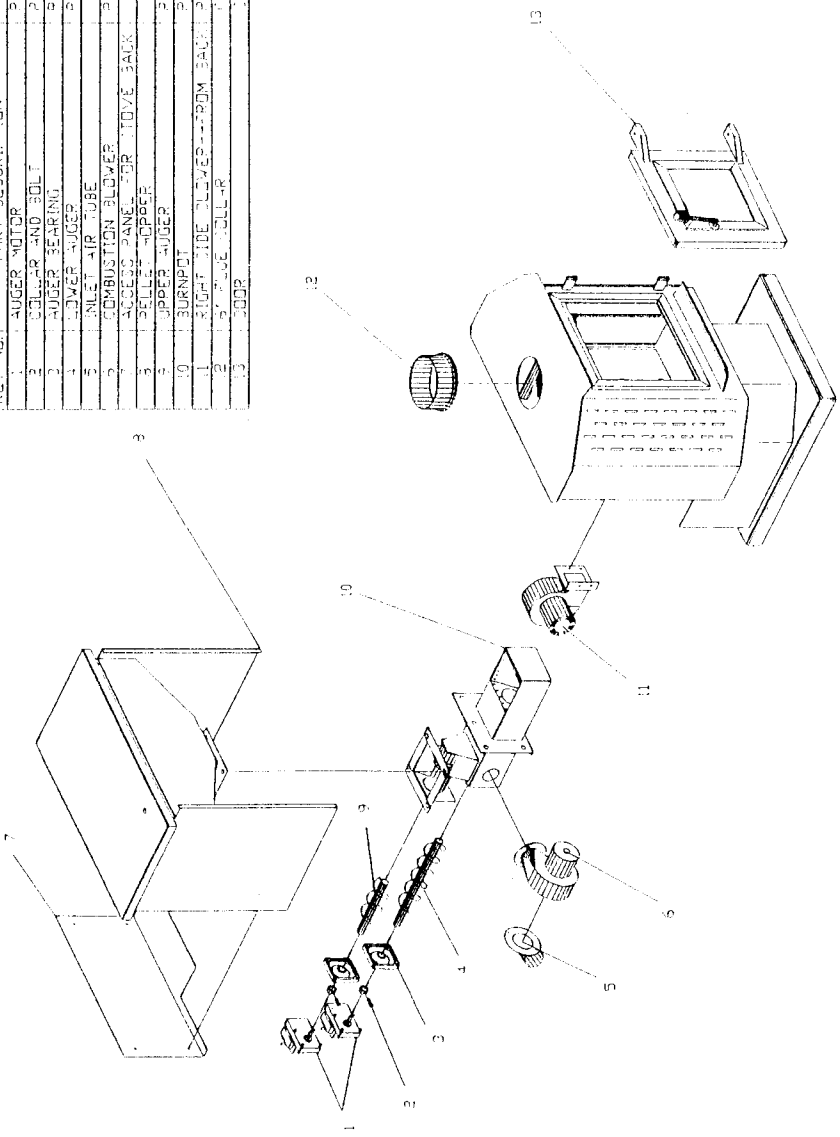

Pellet Unit Wiring Diagram
for 25-PFSP

