

Service Manual

Experience™ Series

P62 & P82 Consoles

P62



P82



Contents

Introduction	1
Safety Guidelines	3
Safety guideline you need to know and follow:	3
General Information	5
Orientation Convention	5
Controls and Indicators	6
Motion Control Icons	7
Console I/O Port Diagram	8
P82 console	9
P62 console	10
Tools	11
Fastener Torque Specifications	11
Parts	12
Cleaning Solutions	12
Electrical Requirements	12
Input Power	13
Earth ground requirements	13
Operation Verification	14
Verification Tests	14
Console Installation and Removal	17
About	17
Console I/O Port Diagram	17
P82 console I/O port diagram	17
P62 console I/O port diagram	18
Removal Procedure	20
Installation Procedure	22
Basic Installation Steps	22

Locating the Interface Cables and Hardware	22
Installing the Power Supply	24
Installing the Console	24
Updating the operating system software	28
Registering the console	28
System Settings Setup (Display & Workout Limits)	29
TV Channel Guide Setup	29
Media Adapter Console Setup	29
Verify the console operation	29
Setup and Configuration	31
About	31
Topic Content	31
Cloning the System Settings	32
About	32
Exporting the system settings	32
Importing the system settings	32
Cloning the TV Channel Guide	34
About	34
Exporting the TV Channel Guide	34
Importing the TV channel guide	34
Scanning the TV Channel Guide	36
About	36
Using SCAN to create the channel guide	36
Registering the Console	37
About	37
Console Internet Setup	37
Register the console	37
Media Adapter Consoles	39
About	39

Setup and configuration	39
System Software	40
About	40
How to find the operating system software versions	40
Console shortcut - operating system software version	40
How to find the operating & component system software versions	41
How to Update the console operating system software	41
Download the latest operating software version	41
Installing the operating system software	42
Rescue microSD card software install	43
When to use the Rescue microSD card	43
Rescue microSD card update procedure	43
Standard Service Menus	46
About	46
Service Access Codes	46
How to Access the Service Menus	47
Service menu access	47
Touchscreen Calibration shortcut	47
Debug Information Report shortcut	48
Navigating the Service Menus	48
P82 consoles	48
P62 consoles	49
Service Menu (51765761)	50
Settings Menu	50
About menu	51
Equipment Usage menu	53
Maintenance menu	53
System Settings menu	55

System Tests menu	59
Club Settings Service Menu (5651565)	62
Replacement Procedures	64
About	64
Available Replacement Procedures	64
P82 Console Cover Replacement	65
About	65
Procedure	65
Troubleshooting	68
About	68
Introduction To Troubleshooting	68
Basic Steps	68
Validate the customer reported issue:	68
Verify the Input Power (Powered units only)	69
Verify that the console is operating correctly	69
Review the Error Log or CPA Event Log for any active error codes	69
Verify (reproduce) the issue.	70
Perform hardware validation diagnostic tests	70
Verify Club Settings	70
Verify that there are no new error codes	70
Verify service bulletins	70
Standard Error Codes	71
About	71
Viewing Error Codes (Error Log & Event Log)	72
Error Code and Troubleshooting Guide	72
Troubleshooting with Error Codes	72
CPA Event Log	74
About	74
Touchscreen Console (P62, P80, and P82) CPA Event Log	75

Active Status Light (ASL)	77
About	77
ASL Light Equipment Location	77
ASL Overview	78
ASL States	79
ASL Settings and Functions	80
Preventive Maintenance	83
About	83
Maintenance Schedule	83
Parts	84
About	84
P82 Console Parts	85
P82 - Exploded View Diagram	85
P82 - Parts List	86
P62 Console Parts	87
P62 - Exploded View Diagram	87
P62 Parts List	88
Appendix A : Edition Information	i
Edition	i
Additional Documentation	i
Copyright	i
Appendix B : Notices and Safety	ii
Trademarks	ii
Intellectual Property	ii
Warranty	ii
Safety Notices	ii
Service Safety Guidelines	iii

Introduction

If you are not a Precor certified servicer, you must not attempt to service any Precor Product. Call your dealer for service.



WARNING: This service documentation is for use by Precor certified servicer providers only. Personal injury can result from electrical shock and/or mechanical moving parts.

This manual provides service information for the Experience™ Series P62 and P82 series consoles:

P62



P82



This document contains information required to service and maintain the console including: general product information, operation verification, adjustment calibration, replacement, and troubleshooting procedures and preventative maintenance scheduled tasks.



NOTE: This document provides information to service the P 62 and P82 consoles only. For base equipment service documentation, refer to the particular base equipment service manual.

Additional Documentation

There is also an online web version if you have internet access at:  [Online Service Manual](#)

See Also

"General Information" on page 5

"Safety Guidelines" on the facing page

"Operation Verification" on page 14

"Standard Service Menus" on page 46

Safety Guidelines



WARNING: Only Precor certified servicers and technicians are permitted to service Precor products. Personal injury can result from electrical shock and/or mechanical moving parts.

Safety guideline you need to know and follow:

- Read and follow all **Warning** notices to protect yourself from personal injury.
- Read and follow all **Caution** notices to prevent damage to the equipment.
- Read the owner's manual and follow all operating instructions.
- Operate the equipment on a solid, level surface.
- Visually check the equipment before beginning service or maintenance operations. If it is not completely assembled or is damaged in anyway, do not attempt to operate the equipment.
- Never place liquids on any part of the equipment while performing service.
- To prevent electrical shock, keep all electrical components away from water and other liquids.
- Do not use accessory attachments that are not recommended by the manufacturer. Non-OEM accessories can cause injuries.
- Do not stand or climb on the handlebars, display enclosure or cover.
- On a self-powered unit, it will either be necessary to either equip the unit with the optional external power supply or have an assistant pedal on the unit while voltage measurements are being taken. Because of the danger of working on the unit while it is in motion using the optional external power supply is strongly recommended.
- On ATM units when the stairarms are in motion; the generator will operate and produce potentially hazardous voltages even when the battery is disconnected.
- On AMT units with Cardio Theater PVS units will have external power supply and coaxial cable routed through the bottom of the unit to the top of the display console. Cord management must be maintained
- On ATM units, a pinching hazard exists when the unit is operated. It is possible to seriously pinch a finger. The AMT can be mechanically locked by inserting a screwdriver through the primary sheave and frame.
- On treadmills, removing the hood exposes high voltage components and potentially dangerous machinery. Exercise extreme caution when you perform maintenance procedures with the hood removed.

When servicing the equipment:

- During service operations you will be very close to moving machinery and voltage bearing components:

- Remove jewelry (especially from ears and neck),
- Tie up long hair,
- Remove neck ties, and
- Do not wear loose clothing

See Also

"Notices and Safety" on page ii

"Safety Notices" on page ii

General Information

The P62 and P82 are touchscreen consoles that provide the user interface and machine control functions for the Precor 680, 780, and 880 line of cardiovascular equipment including Treadmills "TRM", Elliptical Fitness Crosstrainers™ "EFX®", Adaptive Motion Trainers® "AMT®", Recumbent "RBK" and Upright "UBK" bikes.

Both consoles support the Standard Service & Diagnostic menus utilized across Precor cardio machines used by technicians to service and maintain the equipment, see "[Standard Service Menus](#)" on page 46. However, there are minor differences in the hardkey and display softkey functionality, see "[Navigating the Service Menus](#)" on page 48.

Console system software is easily updated and kept current using a USB flash drive connected to the chin USB port used to upload software files. The same chin USB port makes it easy to clone (export/import) system settings and TV Channel Guide mappings between consoles.

These consoles also support the Active Status Light (ASL maintenance and machine operating status light). The console provides the user interface, status information, and control functions for the ASL, see "[Active Status Light \(ASL\)](#)" on page 77.

The P62/P82 consoles are powered from an external AC/DC power adapter plugged into the facility 115 VAC power outlets, except for treadmills. On treadmills, the AC/DC adapter is spliced into the treadmill MC input power allowing the console power to be controlled by the treadmill ON/OFF power switch.

Orientation Convention

The equipment orientation (front, right, left, back) used in manual is referenced to a user standing on the equipment facing the console.

Console Orientation



ID	Description
1	Left
2	Right
3	Front
4	Back

Controls and Indicators

Mechanical single and dual motion controls are used to vary the speed (resistance) and incline levels with values shown on displays located directly above the control. There is also other switches that control the media functions such as volume and TV channels. The P82 also provides an audio headphone jack and USB power supply for charging mobile devices. An LCD touchscreen display provides user workout program control and exercise monitoring information, interface for the Preva™ Network, television (either analog or IPTV), and service/maintenance software.







ID	Part
1	Pause
2	Incline or stride height* indicator
3	Intensity or resistance indicator*
4	Volume up/dwn
5	Channel up/dwn
6	Mute
7	Audio jack (Headphone "HP" jack)
8	USB port (charger/SW updates)
Notes	* Stride height indicator for AMT only. ** Incline indicator only on the dual-motion controls.

Motion Control Icons

Each exercise machine type has a unique set of console motion control icons. Depending on the machine type and model, the console can be fitted with either a single or a dual motion control. The icons can also be used to identify which product type the console is designed to work with,

The P82 console cannot be used between different machine product types (i.e. treadmills and AMTs). However, the same P82 can also be used on different product lines within the same product type. For example, a treadmill P82 could be used on either the TRM 700 line or TRM 800 line treadmills.

Motion Control ICONS	Machine Type: ICON Metric(s)
 TRM	Treadmill (TRM): INCLINE, SPEED
 EFX	Elliptical (EFX): INCLINE, RESISTANCE
 AMT	AMT: STRIDE HEIGHT, RESISTANCE
 UBK/RBK	UBK & RBK bikes: RESISTANCE
 CLIMBER	Climber (CLB) : STEP RESISTANCE



Note: Consoles are specific to a particular cardio machine type and cannot be used on a different type of machine. You can use the motion control icons to determine which machine type the console is designed to work with.

Console I/O Port Diagram

- P62 I/O Port Diagram, see "P62 console" on page 10.
- P82 I/O Port Diagram, see "P82 console" on the facing page.

P82 console

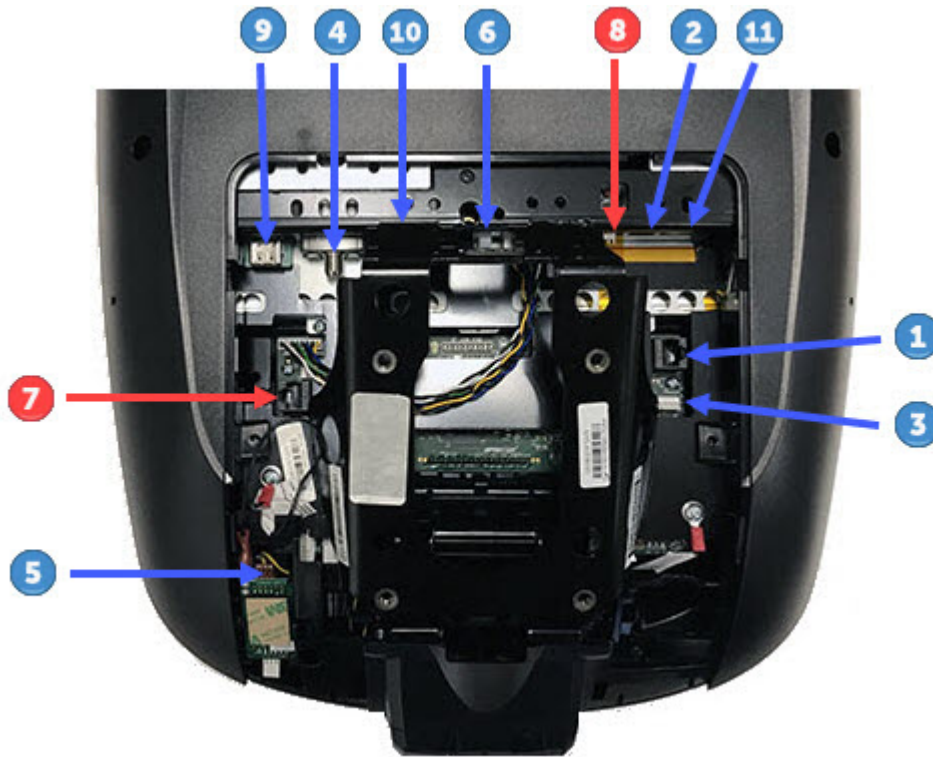

CONNECTOR LOCATION	INTERFACE DESCRIPTION	CONNECTOR/DEVICE TYPE
1	COMM Data Cable ⁽¹⁾	RJ45 eight pin modular (flat gray Data cable).
2	Ethernet (LAN) Cable ⁽¹⁾	RJ45 eight pin modular (round black LAN cable).
3	E-Stop Switch Cable (TRM Only)	Six pin strip, keyed.
4	RF (TV) Cable	F-Type coax.
5	HHHR Sensor Input Cable	Four pin strip, keyed.
6	Console DC Input Power	Two pin plug.
7	CSAFE ⁽²⁾	Not Used.
8	DEBUG Port ⁽²⁾	OEM use only.
9	Media Adapter HDMI Video/Au-	HDMI connector

CONNECTOR LOCATION	INTERFACE DESCRIPTION	CONNECTOR/DEVICE TYPE
	dio cable ⁽³⁾	
10	Media Adapter IR Transmitter cable ⁽³⁾	3- pin plug
11	microSD mass storage	.microSD memory card



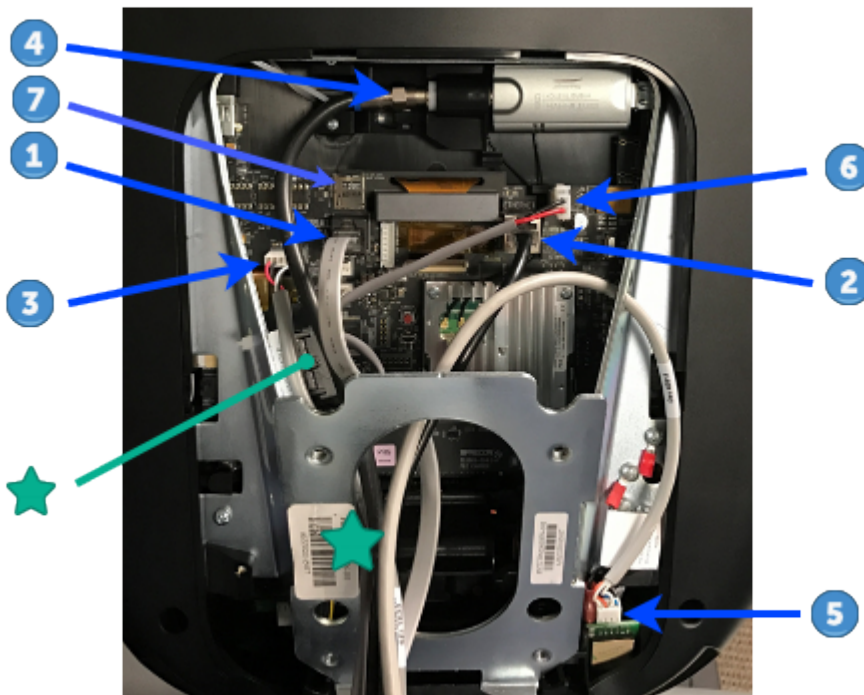

Notes:

- (1) Be careful to NOT connect the COMM Data Cable 1 to the Ethernet input port 2 which can damage the CPA board.
- (2) Do not connect cables to this port.
- (3) Optional Media Adapter cables.

P62 console



CONNECTOR LOCATION	INTERFACE DESCRIPTION	CONNECTOR/DEVICE TYPE
1	COMM Data Cable ⁽¹⁾	Black color RJ45 eight pin modular (flat gray Data cable).
2	Ethernet (LAN) Cable ⁽¹⁾	Silver color RJ45 eight pin modular connector (round black LAN cable).

CONNECTOR LOCATION	INTERFACE DESCRIPTION	CONNECTOR/DEVICE TYPE
3	E-Stop Switch Cable (TRM Only)	Six pin strip, keyed.
4	RF (TV) Cable with Isolator	F-Type coax
5	HHHR Sensor Input Cable	Four pin strip, keyed.
6	DC Input Power	Two pin plug (see )
7	microSD mass storage	.microSD memory card
	Ferrite cable clamp	The input power cable must be looped thru the ferrite cable clamp.
<p>Notes:</p> <p>(1) Be careful to NOT connect the COMM Data Cable  to the Ethernet input port  which can damage the CPA board.</p>		

Tools

Required repair tools and service items.

Tools/Service Items	Tools/Service Items
US and Metric Hex Key set	7/16 " RF coax conn torque wrench 2.4 in-lbs (0.271 Nm)
DVM Multimeter	Compatible heart rate chest strap (supports Polar GymLink) or Precor heart rate chest strap, PN PPP0000AT190012101)
...Standard and Philips screw driver set	

Fastener Torque Specifications

This table provides a summary of system fasten torque specifications.

System Component	Specification
RF Coax Connector	2.4 in-lbs (0.271 Nm)
Plastic Cover Screws	20 in-lbs (2.3 Nm)
Flathead Screws	25 in-lbs (2.8 Nm)
Console Fasteners	180 in-lbs (20 Nm)

Parts



IMPORTANT: Always purchase OEM replacement parts and hardware from Precor. If you use parts not approved by Precor, you could void the Precor Limited Warranty. Use of parts not approved by Precor may cause injury.

Exploded View Diagram and Parts List

This document provides a copy of the parts *Exploded View Diagram* and *Parts Identification List* that you can use as a quick reference, see "Parts" on page 84. It is recommended that servicers go to the Precor Partner website [Precor Partner Website](#) to access the most current parts information.

Cleaning Solutions

Wipe down equipment with recommended cleaning solution. Use dry cloth to remove residue solution.

- **General:** 1 oz. mild soap to 30 oz. water (Ex. Simple Green).
- **Console and PVS:** a diluted solution of one part 91% Isopropyl alcohol to one part water.



CAUTION: Do not use acidic cleaners and do not spray directly onto the equipment surfaces.

Electrical Requirements

Each P82 utilize an external 12 VDC / 50 W power supply.

The power supply AC input is plugged into the facility AC power outlet and the supply output cable is connected to the console power input connector except for treadmills.

For treadmill installations, The power supply input power is hardwired to the line filter output and the earth ground is directly connected to the line filter chassis ground tab (a power supply adapter wire bundle is included with treadmill P82 installations).



CAUTION: A maximum of 10 consoles can be connected to one 20-amp dedicated branch circuit. If the branch circuit has any other devices connected, the number of P82 consoles must be reduced by the wattage of the other devices. .

Input Power

Console input: 12 VDC nominal (range: 8 VDC - 16 VDC), 50 W nominal (60 W max)

Ext Power Supply input: 100 - 240 VAC / 15 or 20 Amp

Earth ground requirements

- Self-powered equipment (EFX, AMT & Bikes): The earth ground is connected from the facility power outlet earth ground through the power supply brick.
- Powered equipment (Treadmills): The power supply input power cables are connected to the line filter output power tabs. The earth ground wire is connected directly to the line filter chassis ground connector tab (a power supply adapter wire bundle is included with treadmill P82 installations).



WARNING: For operator safety and to minimize electrostatic discharge conditions, for AC self-powered equipment, the earth ground must be connected through the power supply brick.

Operation Verification

This section provides a method of verifying the P82 operation. Check the P82 operation at the end of a maintenance procedure and when it is necessary to ensure that the console is operating properly.

Verification Tests

Operation/Verification Test	
<input type="checkbox"/>	Verify that the TV cable, Ethernet LAN cable, and power cables are not caught on or pinched by the equipment moving components, wheels, or frame.
<input type="checkbox"/>	Verify that the console powers up to the "Welcome" banner.
<input type="checkbox"/>	Verify that the console has the most current software version installed, update the software as necessary, see "System Software " on page 40.
<input type="checkbox"/>	<p>Do the following console Diagnostic System Tests (Settings > System Settings > System Tests):</p> <ul style="list-style-type: none"> • Touchscreen Calibration: Follow screen prompts to complete test. When the test is completed the console will automatically exit and return to the System Tests menu. • Touchscreen Test: Verify that there is a trace created that follows your finger movement across the touchscreen surface. Select Finish to exit. move your finger and verify that a trace follows • Backlight Test: Tests the display backlight brightness. Follow prompts to complete test. • RGB Test: Touch the screen to cycle through the test colors: Red, Green, Blue, White, & Black. Returns to the System Tests menu when completed. • Numeric Backlight Test: Tests the controls numeric display brightness. Returns to the System Tests menu when completed. • Numeric Display Test: Tests the controls numeric display. Returns to the System Tests menu.
<input type="checkbox"/>	<p>Verify internet connectivity. Verify the following Connectivity parameters (System Settings > Connectivity):</p> <ul style="list-style-type: none"> • Status: Connected • IP Address: Should show a valid IP address, not 0.0.0.0.
<input type="checkbox"/>	<p>Verify the TV Channel Guide (System Settings > TV Settings > Channel Guide):</p> <ol style="list-style-type: none"> 1. Verify that available channels match the channel list (check with the facility operator).

Operation/Verification Test	
	<ol style="list-style-type: none"> 2. Rename the channels if necessary. 3. Set the default channel, if applicable.
<input type="checkbox"/>	<p>Verify the movement controls:</p> <ul style="list-style-type: none"> • INCLINE and SPEED (TRM) • INCLINE and RESISTANCE (EFX) • STRIDE HEIGHT, RESISTANCE (AMT) • RESISTANCE (UBK/RBK bikes, CLB)
<input type="checkbox"/>	<p>Verify the handlebar HR sensor and the wireless chest strap heart rate monitor (HRM) function:</p> <p>Handheld handlebar HR sensor test</p> <ol style="list-style-type: none"> 1. Start a workout and grasp the left and right handlebar heart rate sensors. The heart icon will blink for approximately 10 seconds while the heart rate is being computed. You must maintain contact with both metal HR sensors on each handlebar to ensure an accurate measurement. 2. Within approximately ten seconds, your heart rate number appears in the HEART RATE (HR) display. Perform the following checks if the HR number does not appear: <ol style="list-style-type: none"> a. Verify that the HR cable is properly connected. b. If the HR test failed, repeat the test with a different person. In rare instances, the handlebar sensors may not work properly for a few individuals. <p>Wireless HR Test Strap Test</p> <p>Use a touchscreen (P62, P80, and P82) compatible commercially available heart rate chest strap to verify the wireless heart rate function (Any chest strap that supports Polar GymLink technology or you can purchase a chest strap from Precor, pn PPP0000AT190012101) .</p> <ol style="list-style-type: none"> 1. Put on the heart rate chest strap and verify that the chest strap is operating correctly on a different machine and touchscreen console. 2. Then move to the test machine and console and verify that the test console wireless heart rate function is operating correctly and is properly indicating your heart rate. <p style="text-align: center;">DO NOT hold onto the handlebars during this measurement or you'll override the chest strap HR results.</p> <p>Alternative Test Method</p> <p>If you have a Precor Polar HRM simulator transmitter test box (Precor PN: PPP000000020045101), then use the test box to verify the wireless heart rate func-</p>

Operation/Verification Test	
	tion. <ol style="list-style-type: none">1. Switch on the HRM simulator transmitter test box and verify the console is properly indicating the test box transmitted heart rate.
<input type="checkbox"/>	Verify the media controls and output. <ol style="list-style-type: none">1. Select QUICKSTART and verify the following media controls and outputs:<ul style="list-style-type: none">• Channel up/down controls• Headphone jack (connect headphones)• Volume up/down controls• Verify the USB port charger function (connect a smart phone or other USB media device).

Console Installation and Removal

About

This procedure provides instructions to remove and install the P82 console.

The console armor is designed to attach to cardio equipment bases (including the EFX, TRM, AMT, and RBK/UBK bikes) that use a universal four bolt mounting plate. The number of interface cables that connect to the console will vary depending on the console type (standard or media adapter models) and the type of equipment.

Console I/O Port Diagram

P82 console I/O port diagram

P82 console I/O port diagram

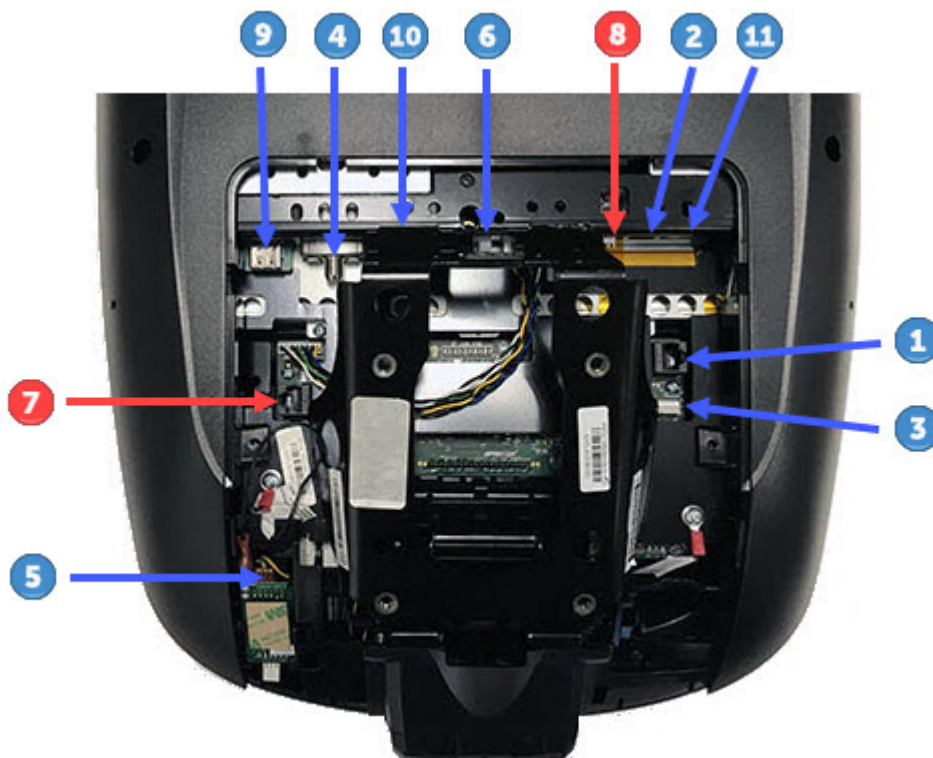

CONNECTOR LOCATION	INTERFACE DESCRIPTION	CONNECTOR/DEVICE TYPE
1	COMM Data Cable ⁽¹⁾	RJ45 eight pin modular (flat gray Data cable).

CONNECTOR LOCATION	INTERFACE DESCRIPTION	CONNECTOR/DEVICE TYPE
2	Ethernet (LAN) Cable ⁽¹⁾	RJ45 eight pin modular (round black LAN cable).
3	E-Stop Switch Cable (TRM Only)	Six pin strip, keyed.
4	RF (TV) Cable	F-Type coax.
5	HHR Sensor Input Cable	Four pin strip, keyed.
6	Console DC Input Power	Two pin plug.
7	CSAFE ⁽²⁾	Not Used.
8	DEBUG Port ⁽²⁾	OEM use only.
9	Media Adapter HDMI Video/Audio cable ⁽³⁾	HDMI connector
10	Media Adapter IR Transmitter cable ⁽³⁾	3- pin plug
11	microSD mass storage	.microSD memory card

Notes:

- (1) Be careful to NOT connect the COMM Data Cable 1 to the Ethernet input port 2 which can damage the CPA board.
- (2) Do not connect cables to this port.
- (3) Optional Media Adapter cables.

P62 console I/O port diagram

P62 console I/O port diagram

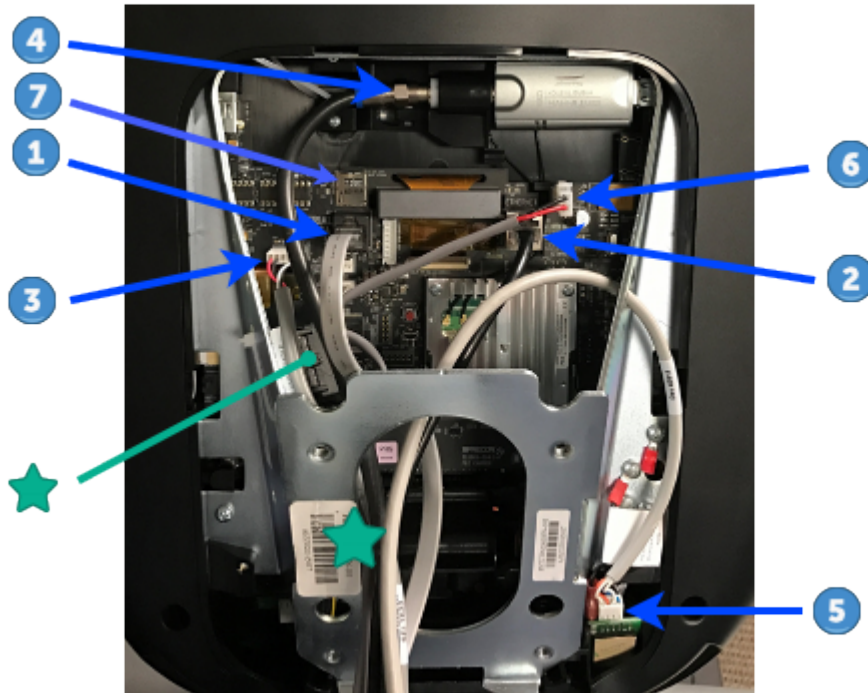

CONNECTOR LOCATION	INTERFACE DESCRIPTION	CONNECTOR/DEVICE TYPE
1	COMM Data Cable ⁽¹⁾	Black color RJ45 eight pin modular (flat gray Data cable).
2	Ethernet (LAN) Cable ⁽¹⁾	Silver color RJ45 eight pin modular connector (round black LAN cable).
3	E-Stop Switch Cable (TRM Only)	Six pin strip, keyed.
4	RF (TV) Cable with Isolator	F-Type coax
5	HHHR Sensor Input Cable	Four pin strip, keyed.
6	DC Input Power	Two pin plug (see ★)
7	microSD mass storage	.microSD memory card
★	Ferrite cable clamp	The input power cable must be looped thru the ferrite cable clamp.

Notes:
 (1) Be careful to NOT connect the COMM Data Cable 3 to the Ethernet input port 4 which can damage the CPA board.

Removal Procedure

Removal Procedure

1. If the console is operable, create a cloned system settings USB flash drive, see "[Console Installation and Removal](#)" on page 17. This will save both the system settings and TV channel list to the USB drive. This USB drive will be used to configure the replacement console.



TIP: Creating a cloned system settings USB drive (exporting the system settings) allows you to clone (import system settings) the system settings and TV channel list to the replacement console.

2. Disconnect (or switch OFF) the console power:
 - a. For treadmills, switch the ON/OFF circuit breaker OFF.
 - b. For self-powered equipment, unplug the console power supply input power cord.
3. For treadmill installations, remove the treadmill dash back cover, see the treadmill Service Manual (download from the [Precor Partner's](#) website). Retain part(s) and/or fastener(s) for installation.
4. Remove the console lower bezel cover, see "[P82 Console Cover Replacement](#)" on page 65. Retain bezel cover for installation.
5. Remove the four 5/32" (4 mm) hex key console mounting bolts. Retain part(s) and/or fastener(s) for installation.



Note: All Precor equipment bases use a four bolt console mounting plate to secure the console. Treadmills require the rear dash cover to be removed to access the console mounting fasteners.

6. Tilt the console rearward away from the dash and set the console armor onto the mounting plate hook.
-



Ex: Treadmill Console Setting on Mounting Plate Hook

7. Carefully remove the console-base interface cables. Disconnect the following cables, see "P62 console I/O port diagram" on page 18 or "P82 console I/O port diagram" on page 17.

- a. E-Stop Safety Switch cable **3** (Treadmills only).
- b. COMM Data cable **1**.
- c. Ethernet (LAN) cable **2**.
- d. HHR cable **5**.
- e. Power cable **6**.
 - On P62 consoles, remove the cable from the ferrite cable clamp .
- f. RF (TV) Coax cable **4**:
 - On P62 consoles, remove the RF cable from the TV tuner isolator (the isolator is part of the P62 TV tuner assembly)

Media Adapter Consoles

- a. Media Adapter HDMI Video/Audio cable **9**.
- b. Media Adapter IR Blaster cable **10**

 **TIP:** Before removing the cables, take a picture of the installed cable connections and routing. These pictures can be used as a guide to reinstall the cables.

8. Remove the console from the base.
-

Installation Procedure

Installation Procedure

Basic Installation Steps

Installing the console entails completing each one of the following basic steps:

1. "Locating the Interface Cables and Hardware" below (first time installations)
2. "Installing the Power Supply " on page 24 (first time installations or replacement).
3. "Installing the Console " on page 24
4. "Updating the operating system software" on page 28.
5. "Registering the console" on page 28
6. "System Settings Setup (Display & Workout Limits)" on page 29
7. "TV Channel Guide Setup" on page 29
8. "Verify the console operation" on page 29

Locating the Interface Cables and Hardware

(First time Installations only)

1. Locate hardware and interface cables.
 - a. Unpack the contents of the console shipping box:
 - the Console
 - the  P82 Installation Guide (Literature kit package)
 - the accessory box (contains interface cables and hardware).
 - b. Unpack the accessory box contents:
 - the Ethernet (LAN) cable
 - the RF (TV) cable
 - the console power cable
 - the AC/DC power adapter brick
 - the adapter brick input power cord (self-powered machine)
 - the adapter brick input power adapter cable (treadmills)
 - the adapter brick output power cable
 - the Entertainment Plate (Accessory Jack).

Media Adapter Consoles

- the IR Transmitter interface cable
- the HDMI cable
- the IR Transmitter module.

Cables and Hardware



Ethernet LAN Cable



RF Coax Cable



**Entertainment Plate
(Accessory Jack)**



Power Cable



**AC/DC Adapter
(Self-powered machines)**



**AC/DC Adapter
(Treadmills)**

Media Adapter cables/hardware



IR Transmitter Cable*

HDMI Cable*

IR Transmitter Module*

Installing the Power Supply

(First time Installation or power supply replacement only)

1. Install the console power supply AC/DC adapter and cables:

Refer to the specific equipment *Assembly Guide* for instructions to install the console power supply AC/DC adapter and cables. You can download the assembly guide from the Precor.com website (go to the specific Cardio equipment home page, scroll down to the "Brochures and Manuals" drop down menu and select the equipment specific 800 Line Assembly Guide).

Installing the Console

This procedure installs the console onto the equipment base.

1. For first time console installations, install the following console-base I/O cables : the Ethernet cable **2**, RF (TV) cable **4**, and the entertainment plate on the base. Refer to the equipment *Assembly Guide* for instructions (download from the Precor.com equipment home page).
 - a. For Media Adapter consoles, also install the IR Transmitter cable **10**, HDMI cable **9**, and IR Transmitter module. Refer to the *Networked Fitness Media Adapter Guide* for installation instructions (download from the "[Experience™ Series P82 Console](#)" home page (scroll down to the "Brochures and Manuals" select drop-down box and select *Network Fitness Media Adapter Guide*)).
 2. For treadmill installations, remove the treadmill dash back cover to gain access to the console four mounting bolts, see the treadmill Service Manual (download from the [Precor Partner's](#) (Precor Connect) website).
 3. Remove the console lower bezel, see "[P82 Console Cover Replacement](#)" on page 65.
 4. Set the console armor onto the base mounting plate hook tilting rearward away from the dash. The hook holds the weight of the console and allows room to route and connect the interface cables.
-



Ex: Treadmill Console Setting on Mounting Plate Hook

5. Install the following list of I/O interface cables. Hold the console while carefully routing and connecting the I/O interface cables, see "[Console I/O Port Diagram](#)" on page 17.

a. **RF (TV) Coax cable** 4 :

- On P82 consoles, route the RF cable from the base mounting post upward through the console armor exiting through the upper left side, Connect the RF cable to the RF Tuner input 4 . Do not over tighten the RF coax connector, torque to 2.4 in-lbs (0.271 Nm) (approx. finger tight).
- .On P62 consoles, route the RF cable from the base mounting post upward through the top left side of the console armor continuing up the left side bending right across the top of the armor opening connecting to the TV tuner isolator coax cable input 4 (the isolator is part of the P62 TV tuner assembly). Do not over tighten the RF coax connector, torque to 2.4 in-lbs (0.271 Nm) (approx. finger tight).

b. **Power cable** 6 :

- On P82 consoles, route the Power cable from the base mounting post upward through the console armor exiting through the top center connecting to the console DC Power input port 6 .
- On P62 consoles, single loop the power cable through the ferrite cable clamp exiting the top of the armor connecting to the input power port 6 . Open the ferrite cable clamp and loop the power cable around and through the clamp one time

then snap the clamp cover closed to secure the cable. Leave enough cable length to reach the console power input port **6**.

c. **HHHR cable **5**** .:

- On P82 consoles, route the HHHR cable from the base mounting post upward through the console armor exiting through the left side opening connecting to the HHHR PCA sensor input port **5**.
- On P62 consoles, route the HHHR cable from the base mounting post upward through the console armor exiting through the bottom right side opening connecting to the HHHR PCA sensor input port **5**.

d. **Ethernet (LAN) cable **2**** :

- On P82 consoles, route the Ethernet (LAN) cable from the base mounting post upward through the console armor exiting through the right side opening connecting to the console Ethernet (LAN) input port **2**.



CAUTION: On P82 consoles, the microSD card **11** can be inadvertently ejected while installing the Ethernet cable. Make sure the microSD card **11** remains properly seated after installing the Ethernet cable. .

- On P62 consoles, route the Ethernet (LAN) cable from the base mounting post upward through the console armor exiting through the top right side connecting to the console Ethernet (LAN) input port **2**.

e. **COMM Data cable **1**** :

- Route the cable from the base mounting post upward through the console armor exiting on the right side connecting to the console COMM Data input port **1**.
- Route the cable from the base mounting post upward through the console armor exiting on the top left side connecting to the console COMM Data input port **1**.

f. **E-Stop Safety Switch cable **3**** (Treadmills only):

- On P82 consoles, route the cable from the base mounting post upward through the console armor exiting on the right side connecting to the console E-Stop input port **3**.
- On P62 consoles, route the cable from the base mounting post upward through the console armor exiting on the top left side connecting to the console E-Stop input port **3**.

Media Adapter Consoles

a. **Media Adapter HDMI Video/Audio cable** .

On P82 consoles, route the Media Adapter HDMI Video/Audio cable from the base mounting post upward through the console armor exiting through the upper left side connecting to the Media Adapter HDMI input port .

b. **Media Adapter IR Blaster cable** .

On P82 consoles, route the Media Adapter IR Blaster cable from the base mounting post upward through the console armor exiting through the top connecting to the console Media Adapter IR Blaster cable input port .

6. Carefully position the console onto the base equipment display mounting plate. While positioning the console, push extra cable length down through the display plate center hole and make sure the cables are not pinched between the console armor and base mounting plate. Align the bolt holes and secure using the four 5/32" (4 mm) hex key bolts. Before fully tightening the fasteners, verify the following items and then fully tighten the mounting bolts:

- All cables are fully connected and securely connected.
- Cables are not under tension, pinched, or blocking the console machine control mechanism.



IMPORTANT: Only use mounting screws that came with the console hardware installation kit or the screws that were removed during the console removal. The screw length is important, if too long the covers may be damaged, if too short the console may not be properly secured and will not provide sufficient electrical contact.

7. For treadmill installations, make sure that the cables that route along the front of the dash from the mounting plate center hole to the left and right uprights are routed through the plastic cable guides and secured using the attached flex ties.



Note: All Precor equipment bases use a universal four bolt mounting plate to attach the console to the base unit.

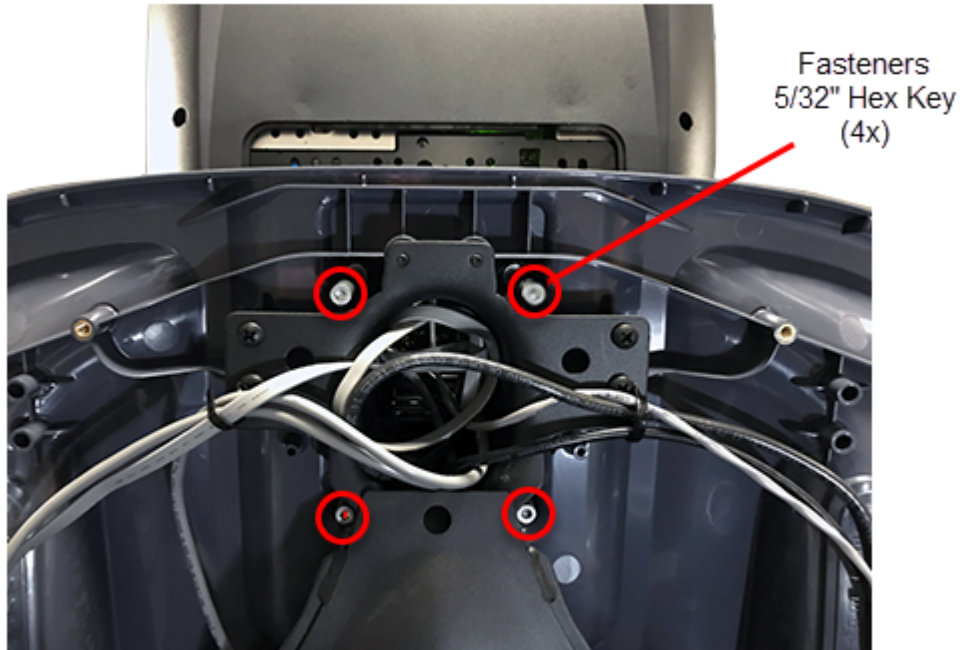

Ex: Treadmill Console Mounting Bolt Location

8. For treadmill installations, reinstall the treadmill dash back cover, see the treadmill model specific Service Manual (download from the [Precor Partner's](#) website).
9. Power up the console:
 - a. For treadmills, connect the treadmill power cord and switch the ON/OFF circuit breaker ON
 - b. For self-powered equipment, plug in the console power supply input power cord.
10. Verify that the console successfully powers up to the "Welcome" banner.

Updating the operating system software

The installed console may not have the latest operating system version installed. This procedure will download and update the console with the latest operating software version.

1. Update the console Operating System software to the most current version, see "[How to Update the console operating system software](#)" on page 41.

Registering the console

This procedure provides instruction to register the console and base with Precor PBS (Preva[®] Business Suite). The console must be connected to the internet to register the console.



Note: This procedure assumes that the facility internet service provider has provided a wired Ethernet LAN connection.

1. Register the console, see "[Registering the Console](#)" on page 37.

System Settings Setup (Display & Workout Limits)

This procedure configures the **Display** and **Workout Limits** settings.

1. If you have a previously cloned System Settings USB drive or you can create one from another configured machine, then import the System Settings, see ["Cloning the System Settings" on page 32](#) and skip to ["TV Channel Guide Setup" below](#). If not, continue procedure.
2. Verify that each of the **Display** settings are set to the facility settings, select **System Settings > Display**, see ["Display menu" on page 56](#).
 - Default Language (default English)
 - Measurement Units (default US Standard)
 - Standby Mode Delay (default 15 minutes)
3. Verify that each of the **Workout Limits** are set to the facility settings, select **System Settings > Display**, see ["Workout Limits menu" on page 58](#).
 - Maximum Workout Duration (default 120 minutes)
 - Maximum Pause (default 30 seconds)
 - Summary Time Out (default 60 seconds)
 - CrossRamp Auto-Level [EFX (default 1), TRM (default 0)]

TV Channel Guide Setup

This procedure configures the **TV Channel Guide**



Note: This procedure assumes that the facility TV service provider has provided a console compliant TV RF input signal.

Select one of the following methods to configure the TV Channel Guide:

1. If you have a previously cloned TV Channel Guide USB drive or you can create one from another configured machine, then import the Channel Guide, see ["Cloning the TV Channel Guide" on page 34](#).
2. If you cannot import an existing Channel Guide, then use the **SCAN** function to create a new **Channel Guide** from the TV RF input signal, see ["Scanning the TV Channel Guide" on page 36](#).

Media Adapter Console Setup

Use this procedure to setup and configure a media adapter console.

1. For media adapter setup and configuration information, see ["Media Adapter Consoles" on page 39](#).

Verify the console operation

1. Verify console operation and return to service, see ["Operation Verification" on page 14](#).
-

Setup and Configuration

About

This topic provides information to help you copy "clone" the system settings, TV channel guide, and procedure to register the console.

Topic Content

"Cloning the System Settings" on the next page

"Cloning the TV Channel Guide" on page 34

"Scanning the TV Channel Guide" on page 36

"Registering the Console" on page 37

"Media Adapter Consoles" on page 39

Cloning the System Settings

About

Cloning system settings allow you to easily copy system settings from one console (parent console) to many consoles (child consoles). This method copies the Connectivity, Display, Media, and Workout Limits settings. Both the parent and child consoles must be mounted on the same equipment type.

Basic steps

1. Export the parent console system settings to a USB flash drive, see "Exporting the system settings" below.
2. Import the system settings from the parent console USB flash drive to the child console, see "Importing the system settings" below.

Exporting the system settings

1. Insert a USB flash drive into the console chin USB port.
2. Access Service menu (51765761) > Settings menu.
3. Select System Settings > Manage Settings.
 - If the "Please insert USB" message shows, either the USB drive was not inserted or the USB drive format is not supported or is corrupted.
4. Select the Export to USB icon to begin the export system settings process.
5. Wait for the "Settings exported successfully to the USB drive" message and then select OK to complete the system settings export.
6. Return to the "Welcome" banner and then remove the USB drive.



IMPORTANT: .Return to the "Welcome" banner before removing the USB drive.

Importing the system settings

1. Insert the cloned system settings USB drive into the child console chin USB port
2. Access Service menu (51765761) > Settings menu.
3. Select System Settings > Manage Settings.
 - If the "Please insert USB" message shows, either the USB drive was not inserted or the USB drive does contain a compatible system setting file.
4. Select the Import from USB icon to begin the export process.
5. Wait for the "Imported settings successfully" message and select OK to complete the settings import.
6. Verify that the Connectivity, Display, Media, and Workout Limits system settings have imported correctly.
7. Return to the "Welcome" banner and then remove the USB drive.



IMPORTANT: .Return to the "Welcome" banner before removing the USB drive.

Cloning the TV Channel Guide

About

Cloning the TV Channel Guide allows you to easily copy the TV channel guide list from one console (parent console) to many consoles (child consoles).

Cloning the TV Channel Guide only copies the TV Channel Guide list, the TV signal and format settings are not copied, refer to the console Owner's Manual and/or the Networked Fitness Media Adapter Guide (downloadable from the precor.com console product website) for more information.

Basic steps

1. Export the parent console TV Channel Guide to a USB flash drive, see "Exporting the TV Channel Guide" below.
2. Import the TV Channel Guide from the parent console USB flash drive to the child console, see "Importing the TV channel guide" below.

Exporting the TV Channel Guide

1. Insert a USB flash drive into the console chin USB port.
2. Access Service menu (51765761) > Settings menu.
3. Select System Settings > TV Settings.
4. Scroll down the TV Settings menu and select Export/Import Channels.
 - If the "Please insert USB" message shows, either the USB drive was not inserted or the USB drive format is not supported or is corrupted.
5. Select the Export to USB icon to start the channel guide file export.
6. If successful, a "TV Channels successfully exported" message will show, select OK to return to the TV Settings menu.
7. Return to the "Welcome" banner and then remove the USB drive.



IMPORTANT: .Return to the "Welcome" banner before removing the USB drive.

Importing the TV channel guide

1. Insert the cloned TV Channel flash drive into the console chin USB port.
2. Select System Settings > TV Settings.
3. Scroll down the TV Settings menu and select Export/Import Channels.
 - If the "Please insert USB" message shows, either the USB drive was not inserted or the USB drive does contain a compatible TV Channel Guide file.
4. Select the Import from USB icon to start the channel guide file import.
5. If successful, a "TV Channels successfully imported" message will show, select OK to exit.

6. Go to the Channel Guide menu and verify that the channel guide list was correctly imported (select TV Settings > Channel Guide).
7. Return to the "Welcome" banner and then remove the USB drive.



IMPORTANT: .Return to the "Welcome" banner before removing the USB drive.

8. Start a workout and verify the console TV operation.

Scanning the TV Channel Guide

About

The console provides a Channel Guide SCAN function that builds a new TV Channel Guide list from the TV RF input signal. If you do not have access too or cannot create a channel guide cloning USB drive then the SCAN function is the next best available solution to create a new channel guide. However it is not with out cost, it can take anywhere from 1 to 2 hours to create the channel guide.



Note: This procedure assumes that the facility TV service provider has provided a console compliant TV RF input signal.

Using SCAN to create the channel guide

This procedure assumes that there is a supported TV RF signal connected to the console tuner input port.

1. Access Service menu (51765761) > Settings menu.
2. Select System Setting > TV Settings > Channel Guide.
3. .Select the SCAN.button at the bottom of the Channel Guide screen.The console will begin to scan the TV input signal for all available channels. Each discovered channel will be listed in the Channel Guide. This process can take anywhere from 1 to 2 hours to complete.
4. Review and verify the Channel Guide list for expected channels. If any channels are missing, then repeat the scan using the Extensive Scan function.
 - a. First enable the Extensive Scan property. From the TV Settings menu, select Extensive Scan > ON > OK.
 - b. Then select Channel Guide > SCAN to start a new channel guide scan.
 - c. When the scan is complete, review the Channel Guide and make any updates as needed.



Note: It can take 1 to 2 hours to complete the extensive scan.

5. Return to the "Welcome" banner, start a workout and verify the console TV operation.

Registering the Console

About

This procedure provides instructions to register the console with the PBS (Preva[®] Business Suite).



Note: This procedure assumes that the facility internet service provider has provided a wired Ethernet LAN connection.

Registering the console is a two step process:

- "Console Internet Setup" below
- "Register the console" below

Console Internet Setup

menu: System Settings > Connectivity

This procedure configures the console "Wired" Ethernet LAN Network connectivity option and assumes that the facility wired Ethernet LAN Network is working correctly (there is also a Wireless internet connectivity option, check with the facility operator).

1. Make sure the facility wired Ethernet LAN network is connected and operating correctly.
2. Set the Network Type parameter to Wired (select Network Type > Wired > OK).
3. Set the Configuration parameter to Automatic (select Configuration > Automatic > OK).
4. After the console has successfully connected to the LAN network, the Status parameter will change from Not Connected to Connected:
 - a. If the Status is Connected, continue procedure to register the console.
 - b. If the Status is Not Connected, make sure the Ethernet LAN cable is properly connected and make sure the LAN network is operating.

Register the console

menu: System Settings > Connectivity

This procedure provides instruction to register the console and base with Precor PBS (Preva[®] Business Suite). The console must be connected to the internet to register the console.

1. Specify the Preva[®] Server server address, select Connectivity > Preva[®] Server and specify the following Precor Preva[®] Server address:
Preva[®] Server address: na.preva.com
2. Select OK to save the address and return to the Connectivity menu.
3. Select Back to return to the System Settings menu.
4. Select Register Equipment to begin the console registration process. Follow the screen prompts and specify the facility PBS (Preva[®] Business Suite) username and password (provided by dispatch or the facility operator).

5. The next screen will prompt you to specify the following registration information:
 - location code (provided by dispatch)
 - base serial number (machine model/serial number bar code label)
 - friendly name (ask facility operator for the friendly name, must be unique for each machine)
6. The next screen "Registration Summary" provides a summary of the specified registration information. Verify the information is correct and select REGISTER to start the registration process.
7. The Summary screen opens when the console registration has successfully completed (typically less than one minute).
8. Note the installed Software Version number and select FINISH to complete the registration.
 - a. If the registration is not successful, the console will prompt for the incorrect or missing information.
9. Update the operating service to the latest version, see "How to Update the console operating system software" on page 41.
10. Ask the facility's Preva administrator to log on to Preva[®] Business Suite and confirm that the console is listed.

Media Adapter Consoles

About

The Media Adapter option allows a P82 or P62 console to display content provided by external receivers instead of the console's internal tuner. For those facilities that use such receivers to process incoming TV signals, the Media Adapter provides the exercisers with exactly the same user experience. They select television channels from the same channel guide and switch between television and other information (such as BROWSER or GOALS) in the same way.

The Media Adapter accepts 720p x 60 frames per second (FPS) video signals through an HDMI connection from one of several different external receivers. (Refer to the receiver list accompanying this Guide for the receiver brands and models we support.) The only control mechanism that these receivers have in common is an infrared (IR) remote control. Because of this, the Media Adapter acts as the remote control for each receiver that is certified to work with it. CAUTION Be sure to install, configure, and test the external receiver.

Setup and configuration

For media adapter setup and configuration information, refer to the Networked Fitness "Media Adapter Guide". The guide can be downloaded from the Precor.com P62 or P82 console web site:

Media Adapter Guide PDF download link: [Media Adapter Guide](#)

System Software

About

The console operating system software is also referred to as the "Preva Operating System" software. This topic will show you how to find the current software versions and how to update the console software.

You can manually update the software or configure the console to automatically update the software (this requires the console to be registered and connected to internet).

When updating the operating system software, the update software bundle installs the following system component software:

- CPA software
- LPCA software
- Qt App software
- Boot Kernal software
- File System software

This software Topic contents:

- "How to find the operating system software versions" below
- "How to Update the console operating system software" on the facing page
- "Rescue microSD card software install" on page 43

How to find the operating system software versions

Console shortcut - operating system software version

1. Power up the console to the default "Welcome" screen.
2. Select the Globe icon (top left).
3. The console installed software version is shown on the top right corner of the Language screen.

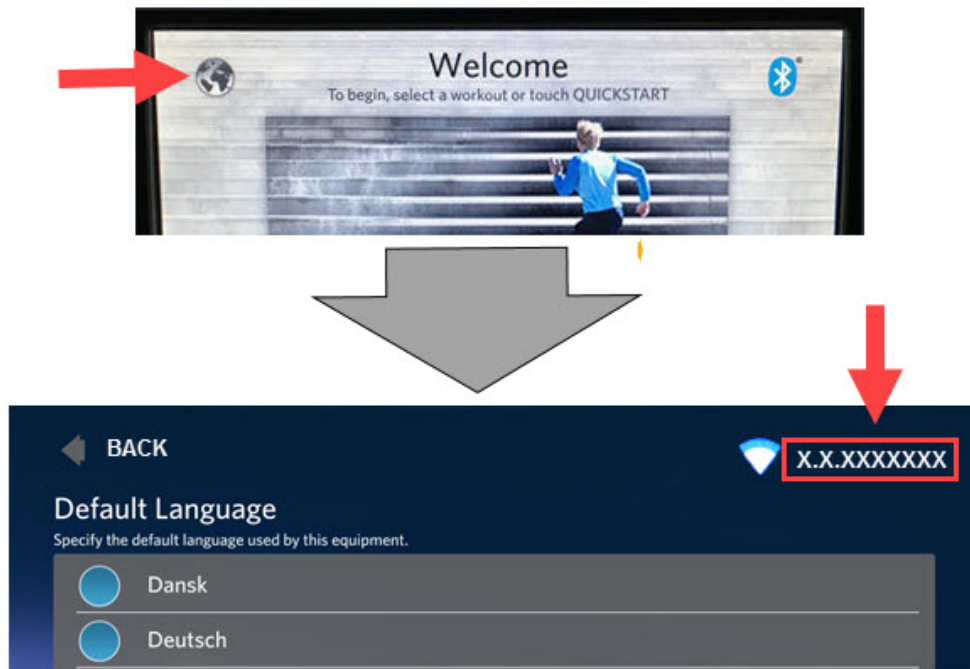

How to find the operating & component system software versions

1. Power up the console to the default "Welcome" screen.
2. Access the Diagnostics menu (access code 51765761).
3. Select About.
4. The Release Bundle Version menu item shows the installed OS software version.
5. Select Release Bundle Version to view the system component software versions:
 - CPA software version
 - LPCA software version
 - Qt App software version
 - Boot Kernel software version
 - File System software version

How to Update the console operating system software

Download the latest operating software version

1. Login to the Precor Partner's (Precor Connect) website and navigate to the "SOFTWARE DOWNLOAD CENTER" website (select Service Documentation > Console Software).

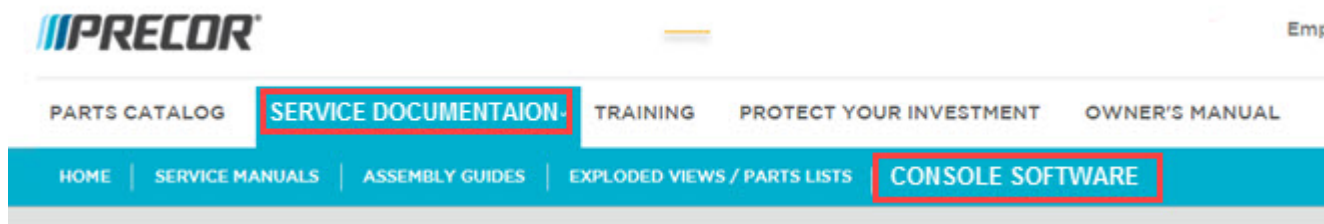

2. Locate the latest (most current) P82 software version.
3. Click the download software link.
4. Enter the Sign in dialog box Username and Password:

Username: software

Password: D0wnl0ads!

5. Select OK to download the P82 software zip file. The browser will automatically begin the download process after selecting OK.

Installing the operating system software

1. On a USB flash drive, create a folder named “precors” in the root directory.
2. Move the downloaded software zip file to the USB flash drive by right-clicking the zip file, selecting “extract all.”, browsing to the “precors” flash drive folder, and selecting “Extract” to download.



IMPORTANT: You must place all software files into the “precors” folder on your USB flash drive. Failure to follow the instructions exactly will result in the console not recognizing the available software update on the USB flash drive.

3. Insert the updated USB flash drive into the console chin USB port.



IMPORTANT: The microSD card **MUST** be properly seated (locked in place) in the microSD port or the chin USB port will not load the software, see "" on page 8.

4. Access the Diagnostic menu (access code 51765761).
5. From the Settings menu, select the Available Updates menu to open the Available Updates screen.



Note: If the menu item is “No Available Updates”, the software was not properly installed on the flash drive. Remove the USB flash drive and reinstall the latest software onto the USB flash drive “precors” folder.

6. Select (highlight) the latest software version and select **INSTALL** to begin the software installation.

Rescue microSD card software install

When to use the Rescue microSD card

Typically the rescue microSD card is required when the OS software has become corrupted and the console fails to power-up to the Welcome banner. Only use the rescue microSD card as a last resort, resetting the console and/or updating the OS software have failed to fix the problem.

The Rescue microSD card will upload the core software required to reboot the console to the OEM factory default state. All custom system settings will be reset to the OEM default settings, treat the console as if it were a brand new console.



IMPORTANT: Using the rescue microSD card will reboot the console to the factory default settings. All setup and customized settings will be reset to OEM default setting including: Registration, TV channel guide, club settings, etc. If the console is networked, the unit will need to be deleted from Preva Business Suite and re-registered.

Rescue microSD card update procedure

1. Disconnect console power (power OFF).
2. Remove the mass storage microSD card and install the Recovery microSD card.
3. Reconnect the console power (power ON).
4. Lightly press and hold down the Boot Select button while momentarily pressing and releasing the Reset button. Starts the reboot process.
 - a. On P82s, you will need two 5/32" (4 mm) or smaller diameter pencil erasers (or similar devices) to press the Reset and Boot Select buttons.
 - b. On P62s, you only need one pencil eraser to press down the Boot Select button.
Use your finger to press and hold the Reset button
5. Continue holding down the Boot Select button until either the green boot-up LED switches ON or you can see on the display that the reboot process has started (approx. 3-5 seconds). When the reboot has started release the Boot Select button.

P82 Rescue microSD software install

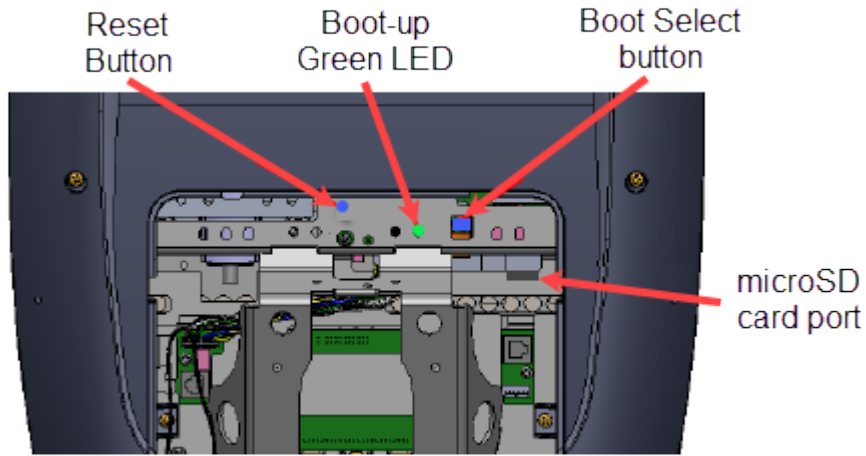

P82 Console

P62 Rescue microSD software install

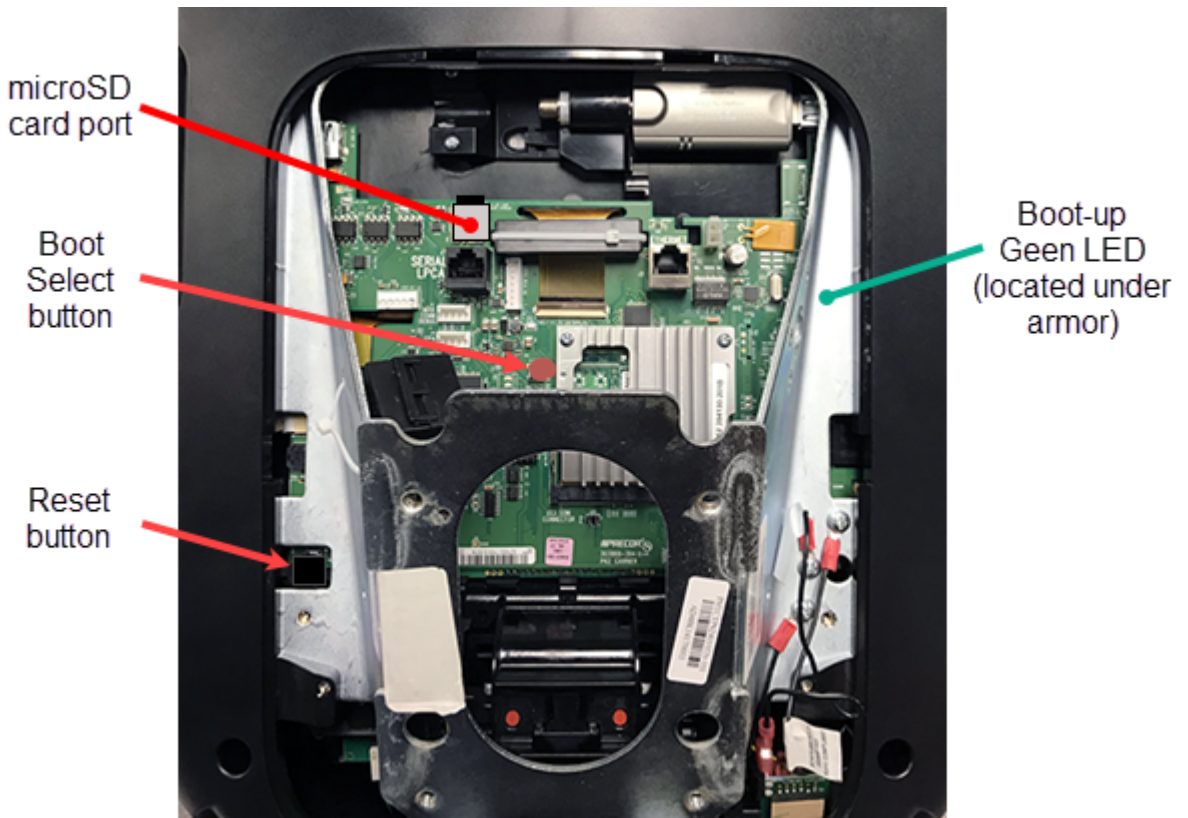

- 6. A successful reboot will show a blue boot-up progress status bar at the bottom of the display. If the progress status bar does not show, repeat the Recovery microSD card boot-up steps. A successful installation will finish with a green check mark ✓, approximately 7-8 minutes. An unsuccessful install will finish with a red "X" ✗.

7. Disconnect the console power (Power OFF).
8. Remove the rescue microSD card and reinstall the mass storage microSD card.
9. Reconnect the console power (power ON).
10. Update the operating system software to the latest version, see "How to find the operating system software versions" on page 40 and "How to Update the console operating system software" on page 41.
11. Reboot the console after the software update has completed, press/release the Reset button or disconnect/reconnect console power.
12. Re-register the console;
 - a. First you will need to contact Precor customer service (Ph: +1 (800) 347-8404) and have the console registration removed from PBS,
 - b. Then do the steps to re-register the console.
13. Configure the console system settings:
 - a. If you have a system settings and TV Channel Guide USB flash drive (or you can create one from another machine), import the system settings and TV Channel Guide settings; 1) insert the settings USB drive into the Chin USB port, access the Service menu and select System Settings > Manage Settings > Import from USB, and 2) insert the TV Channel Guide USB drive into the Chin USB port, access the Service menu and select System Settings > TV Settings > Channel Guide > Import from USB.
 - b. If you do not have a settings or TV Channel Guide USB flash drive, you will need to manually update settings as needed.
14. Reboot the console (press/release the Reset button or disconnect/reconnect power).
15. Verify operation and return to service, see "Operation Verification" on page 14.

Standard Service Menus

About

The P62 & P82 support the Service menu and Club Settings Standardized Service menus used across Precor cardio product lines:

- **Service** (51765761): Service menu provides access to all available equipment service menus, used by service technicians to service and maintain the equipment.
- **Club Settings** (5651565) Club Settings menu is a subset of service menus directed toward club operation, used by club operators to manage, configure, and maintain the equipment.

Each service menu is assigned a unique service access code. To access a service menu, type in the access code at the service menu login screen, see "" on the facing page.

Service Access Codes

Service Access Codes

Supported service menus and access codes.

SERVICE ACCESS CODE	SERVICE MENU	FUNCTION
51765761	Service	Service menu provides access to all available equipment service menus, used by service technicians to service and maintain the equipment.
5651565	Club Settings	Club Settings menu is a subset of service menus directed toward club operation, used by club operators to manage, configure, and maintain the equipment.
65	Information Display	Not supported ⁽¹⁾

1) The Information Display (65) service menu is NOT supported on P62, P80, and P82 touchscreen consoles. Refer to the Service menu (51765761) "About", "Equipment Usage" and "Maintenance" menus.

How to Access the Service Menus

Service menu access

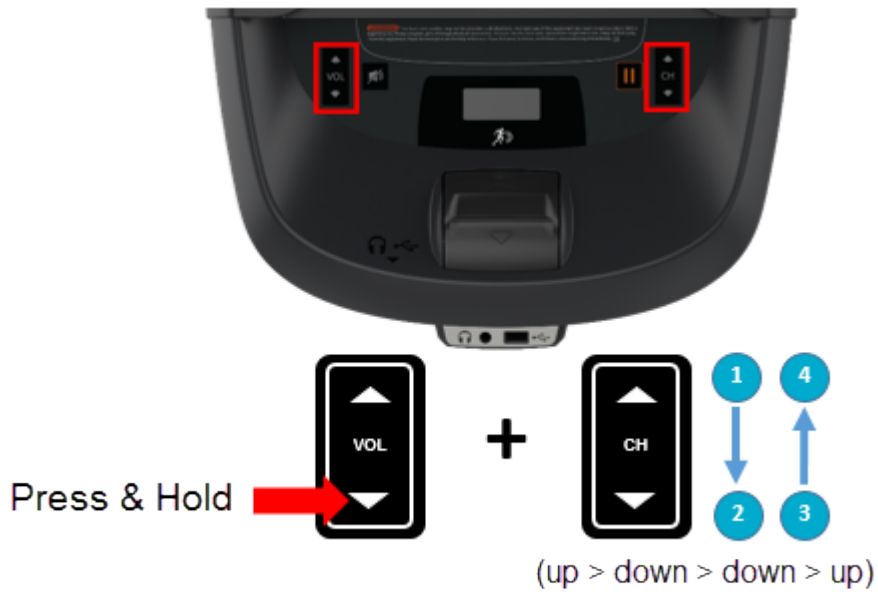

Steps

1. Make sure the console is set to the Welcome banner.
2. Press and hold the VOL down key while pressing CH up > CH down > CH down > CH up:
3. At the Sign-In screen, type in the service access code.

Touchscreen Calibration shortcut

Console shortcut to access the Touchscreen Calibration test.

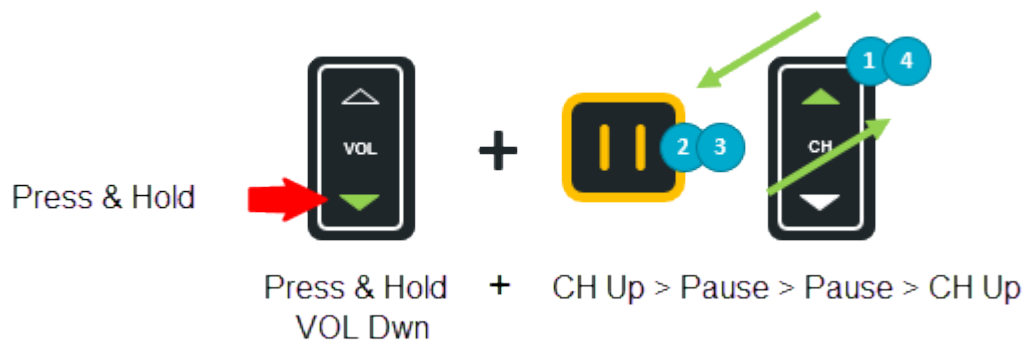

Steps

1. Make sure the console is set to the Welcome banner.
2. Press and hold the **VOL down** hardkey while pressing **CH up > Pause > Pause > CH up**:
3. Touch the designated display positions and follow prompts to complete the touchscreen calibration.

Debug Information Report shortcut

Console shortcut to download an event log debug information report.

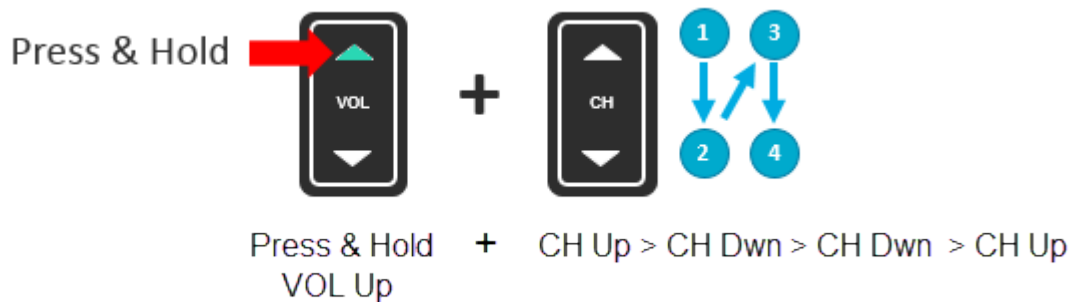

Steps

1. Make sure the console is set to the Welcome banner.
2. Insert a USB flash drive into the Chin USB port.
3. Press and hold the **VOL Up** hardkey while pressing **CH up > CH Dwn > CH Dwn > CH up**:
4. Wait for the download to finish and then remove the USB drive..



IMPORTANT: Do not remove the USB drive until the "Report was successful" message is shown, (approx. 1 min).

Navigating the Service Menus

The P80 and P82 consoles use the console touchscreen touch sensitive controls to select items and navigate the service menus. Only one hardkey "Pause" is used to stop a running diagnostic test.

P82 consoles

:

CONSOLE KEY	FUNCTION/DESCRIPTION
Touchscreen controls	There are various touch sensitive softkey controls (OK, START, STOP, BACK, etc.) and icon controls (image boxes, buttons, etc.)

CONSOLE KEY	FUNCTION/DESCRIPTION
	used to control and operate the console. Make selection by touching the softkey control or icon.
Scroll Up/Dwn	Use your finger to swipe the touchscreen up or down to scroll through menu items. Some menus provide a vertical scroll bar on the screen right side to scroll Up/Dwn.
BACK softkey	<ul style="list-style-type: none"> • Use the touchscreen BACK softkey to return to the previous menu display. • Continue selecting the BACK softkey to exit the service software.
PAUSE hardkey	Stop a running diagnostic test.

P62 consoles

The P62 console uses a combination of touchscreen softkeys , icons, and keypad hardkeys to select and navigate thru the service and diagnostics menus. The P62 uses the **BACK** keypad button to return to the previous menu and the **PAUSE** hardkey to stop a running diagnostic test.

CONSOLE KEY	FUNCTION/DESCRIPTION
Touchscreen controls	There are various touch sensitive softkey controls (OK, START, STOP, BACK, etc.) and icon controls (image boxes, buttons, etc.) used to control and operate the console. Make selection by touching the softkey control or icon.
Scroll Up/Dwn	Use your finger to select while swiping your finger Up/Dwn to scroll through menu lists. Some menus provide an on-screen scroll bar to scroll Up/Dwn.
BACK	<ul style="list-style-type: none"> • On P62 consoles, use the control keypad BACK  button to go back or return to the previous menu. • Continue selecting the BACK hardkey to exit the service software.

CONSOLE KEY	FUNCTION/DESCRIPTION
	 <p style="text-align: center;">P62 Console</p>
PAUSE hardkey	Stop a running diagnostic test.

Service Menu (51765761)

Access code: 51765761 (see "" on page 47)

The Service menu provides access to all available equipment service menus, used by service technicians to service and maintain the equipment.

Settings Menu

Settings Menu

SETTINGS MENU	DESCRIPTION
"About menu" on the facing page	menu: Settings > Software Downloads General information about the machine (serial number, name, type, location, software versions, internet & Wi-Fi connectivity, and the event and error codes (Error Log or CPA Event Log)
"Equipment Usage" on page 53	menu: Settings > Equipment Usage Machine workout usage information (total workout time & distance, last work start/stop times).
"Maintenance menu" on page 53	menu: Settings > Maintenance (ASL equipped machines only) Provides the machine maintenance and operating status information.

SETTINGS MENU	DESCRIPTION
"System Settings menu" on page 55	<p>menu: Settings > System Settings</p> <p>Provides settings to configure the console and machine. Also includes the service diagnostic tests.</p>
Software Downloads menu	<p>menu: Settings > Software Downloads</p> <p>Settings: ON, OFF</p> <p>Enables automatic operating system software downloads:</p> <ul style="list-style-type: none"> • ON: Enables automatic operating system software downloads. • OFF: Disables automatic operating system software downloads. <p>Note: Must be connected to the internet and register with PBS (Preva[®] Business Suite).</p>
Partition Configuration menu:	<p>menu: Settings > Partition Configuration</p> <p>OEM use only, contact Precor Customer Service for information.</p>
(No) Available Updates menu	<p>menu: Settings > No Available Updates or Available Updates</p> <ul style="list-style-type: none"> • No Available Updates: No available software updates can be read from the USB flash drive. • Available Updates: List of available software updates read from the USB flash drive. <p>Used to update the operating system software. The console reads a software update USB flash drive and then changes the menu from No Available Updates to Available Updates. Select Available Updates to view, select, and upload the software, see "How to Update the console operating system software" on page 41.</p>

About menu

About menu

menu: **Service menu (51765761) > Settings > About**

General information about the machine (serial number, name, type, location, software versions, internet & Wi-Fi connectivity, and the event and error codes (Error Log or CPA Event Log).

ABOUT MENU	DESCRIPTION
Event Log	<p>menu: About > Event Log</p> <p>The Event Log contains all connectivity errors and service maintenance error codes.</p>

ABOUT MENU	DESCRIPTION
	.Note: For maintenance service and troubleshooting, use the CPA Event Log and not the Event Log to find the machine maintenance error event codes.
CPA Event Log	<p>menu: About > CPA Event Log</p> <p>The CPA Event Log only contains the machine maintenance and troubleshooting error event codes that are described in the "<i>Error Code Troubleshooting Guide</i>", see "Error Code Troubleshooting Guide".</p> <p>.Note: Use the CPA Event Log and not the Event Log to find the machine maintenance and troubleshooting error event codes.</p>
Console Serial Number	<p>menu: About > Serial Number</p> <p>Console serial number.</p>
Lower Serial Number	<p>menu: About > Serial Number</p> <p>Base serial number.</p>
Friendly Name	<p>menu: About > Friendly Name</p> <p>Friendly name assigned to the equipment by the facility.</p>
Location	<p>menu: About > Location</p> <p>Facility location code.</p>
Release Bundle Version	<p>menu: About > Release Bundle Version</p> <p>Console System Operating software version. Select to show the component system software versions including: the CPA Software, LPCA, Qt App, Boot Kernel, and File System software versions.</p>
Heartbeat Interval	<p>menu: About > Heartbeat Interval</p> <p>OEM use only.</p>
Wired MAC Address	<p>menu: About > Wired MAC Address</p> <p>Wired LAN MAC address</p>
Wi-Fi MAC Address	<p>menu: About > Wi-Fi MAC Address</p> <p>Wireless Wi-Fi MAC address</p>
Network Time Server1	<p>menu: About > Network Time Server1</p> <p>NTP server address</p>
Machine Type	<p>menu: About > Machine Type</p> <p>Specifies the detected machine type: TRED, AMT, EFX, UBK, RBK.</p>
Legal Notices	<p>menu: About > Legal Notices</p> <p>Specifies the trademarks, trade names, etc.</p>

Equipment Usage menu

Equipment Usage

menu: **Service menu (51765761) > Settings > Equipment Usage.**

Machine workout usage information: cumulative hours & distance, number of workout sessions, & last work start/stop times.

EQUIPMENT USAGE MENU	DESCRIPTION
Cumulative Workout Hours	menu: Equipment Usage > Cumulative Workout Distance Machine total workout hours.
Cumulative Workout Distance	menu: Equipment Usage > Cumulative Workout Distance Machine total workout distance.
Cumulative Workout Sessions	menu: Equipment Usage > Cumulative Workout Sessions Machine total number of workout sessions.
Last Workout Start Timestamp	menu: Equipment Usage > Last Workout Start Timestamp The most recent workout start time.
Last Workout End Timestamp	menu: Equipment Usage > Last Workout End Timestamp The most recent workout end time.

Maintenance menu

Maintenance menu

Menu: **Service menu (51765761) > Maintenance**

Provides machine maintenance related information including: routine maintenance due status, machine operating condition, and ASL state.

MAINTENANCE MENU	DESCRIPTION
Recommended Action menu	menu: Maintenance > Recommended Action Range: None, Inspect <ul style="list-style-type: none"> • None: No maintenance required. • Inspect: Maintenance action required. Used to report that there is a maintenance issue that requires attention; it could indicate routine maintenance is due or that a

MAINTENANCE MENU	DESCRIPTION
» Operating Condition	<p>machine failure (error code) has occurred that required attention.</p> <p>menu: Maintenance > Operating Condition Range: Normal, Inspect</p> <ul style="list-style-type: none"> • Normal: No maintenance required. • Inspect: There is a routine maintenance issue or failure condition (error code) that requires immediate attention. <p>.Important: Reset the ASL light state and Motor Controller (MC) status light after repairs a completed.</p>
» Belt Rating	<p>(Treadmills only)</p> <p>menu: Maintenance > Belt Rating Range: 10 - 0 (10 - New condition, ≤ 1 - Replace running belt)</p> <p>A belt rating of 0 or 1 will cause a blue pulsing ASL light indicating that there is a problem with the running belt/deck and requires servicing or replacement.</p> <p>.Important: Reset the Belt Rating after replacing with a new running belt and deck (select Replace).</p>
» Next Maintenance Due	<p>menu: Maintenance > Next Maintenance Due</p> <p>Provides machine next maintenance due remaining mileage or hours. Perform preventative maintenance when the maintenance counter reaches 0.</p> <p>.Important: Reset the maintenance interval after completing routine maintenance service, (select Reset).</p>
Active Status Light (1) (ASL) menu	<p>menu: Maintenance > Active Status Light</p> <p>Indicates the machine operating and maintenance status.</p> <p>Blue Solid: Normal operation Indicates that the ASL has not detected any logged error codes.</p> <p>Blue Pulsing: Preventative maintenance reminder.</p> <ul style="list-style-type: none"> • Treadmills: A belt rating of 0 or 1 will cause a blue pulsing ASL light indicating that there is a problem with the running belt/-deck and is in need of servicing or replacement. • ALL: The maintenance counter starts at 1000 hours counting down to active use hours to 0 indicating preventative maintenance is due. <p>Yellow Solid: Indicates an error has occurred, was self-corrected and the machine can be used. The fault can be cleared.</p> <p>Yellow Pulsing There is a current non-recoverable fault condition, there is a loss of a major function and the machine id out-</p>

MAINTENANCE MENU	DESCRIPTION
	of-service. Machine service is required.
» AS light Brightness (1)	menu: Maintenance > AS Light Brightness Range: Low, Medium, High Set the ASL brightness level.
» Maintenance Reminder	menu: Maintenance > Maintenance Reminder Range: OFF, ON (default) Switch the maintenance reminder function ON or OFF.
Notes: (1) Only used on machines that support the Active Status Light feature.	

System Settings menu

System Settings menu

menu: **Service menu (51765761) > Settings > System Settings.**

Provides settings to configure the console and machine. Also includes the service diagnostic tests.

SYSTEM SETTINGS MENU	DESCRIPTION
Tests menuSystem	menu: System Settings > System Tests Machine diagnostics tests to verify system hardware operation, see " System Tests menu " on page 59.
Connectivity menu	menu: System Settings > Connectivity Connectivity includes Internet network and Preva [®] Server setup and configuration.
» Network Type	menu: System Settings > Connectivity > Network Type Settings: Wired, Wi-Fi Default: Wired
	To connect to a network: <ol style="list-style-type: none">1. Select Network Type > Wired (or Wi-Fi) > Go.2. Select Configure > Configuration > select a network from the list and enter your credentials to access that network.3. Select Back to save settings and return to the Connectivity screen.

SYSTEM SETTINGS MENU	DESCRIPTION
» Configuration	menu: System Settings > Connectivity> Configuration Settings: Automatic (recommended), Manual Default: Automatic Specifies internet connection mode.
» Status	menu: System Settings > Connectivity > Status Range: Connected, Not Connected Specifies internet connection status.
» IP Address	menu: System Settings > Connectivity> IP Address Specifies console internet IP address.
» Preva® Server	menu: System Settings > Connectivity> Preva® Server Specifies Precor Preva server URL (na.preva.com).
Display menu	menu: System Settings > Display Console default display configuration settings: language, units, standby delay, .browser and news reader on/off.
» Default Language	menu: System Settings > Display > Default Language Default: English Specifies the default language.
» Measurement Units	menu: System Settings > Display > Measurement Units Range: US Standard, Metric Default: US Standard Specifies the default measurement units.
» Standby Mode Delay	menu: System Settings > Display > Standby Mode Delay Range: 5, 10, 15, 30, 60 minutes Default: 15 minutes Specifies the idle wait time before entering standby mode.
» Browser	menu: System Settings > Display > Browser Range: ON/OFF Default: ON Show (enable) the Browser app.
» News Reader	menu: System Settings > Display > News Reader Range: ON/OFF Default: ON Show (enable) the News Reader app.

SYSTEM SETTINGS MENU	DESCRIPTION
TV Settings menu	menu: System Settings > TV Settings Configuration TV settings and channel guide.
» Channel Guide	menu: System Settings > TV Settings > Channel Guide TV channel configuration.
» TV Source	menu: System Settings > TV Settings > TV Source Default: Internal Tuner TV input signal source
» Region	menu: System Settings > TV Settings > Region Specifies the TV input signal modulation format for a particular geographical region.
» Default Channel	menu: System Settings > TV Settings > Default Channel Default: Not set TV default channel.
» Skip Unnamed Channel	menu: System Settings > TV Settings > Skip Unnamed Channels Default: ON Skips over unnamed channels.
» Skip Encrypted Channel	menu: System Settings > TV Settings > Skip Encrypted Channels Default: ON Skips over encrypted channels.
» Analog Channels Aspect Ratio	menu: System Settings > TV Settings > Analog Channels Aspect Ratio Range: 4:3, 16:9 Select the analog channel aspect ratio.
» Extensive Scan	menu: System Settings > TV Settings > Extensive Scan Default: OFF Searches all available channel sources.
» Closed Captioning	menu: System Settings > TV Settings > Closed Captioning Default: On Switches close caption feature ON/OFF.
» Export/Import Channels	menu: System Settings > TV Settings > Export/Import Channels Export/Import channel mapping using a USB .flash drive.

SYSTEM SETTINGS MENU	DESCRIPTION
Audio Settings menu	menu: System Settings > Audio Settings Specify the workout duration and equipment limits for your facility.
» Default Wired Headphone Volume	menu: System Settings > Audio Settings > Default Wired Headphone Volume Range: 1 to 15 Default: 6 Sets the default wired headphone jack volume level.
» Default Bluetooth Headphone Volume	menu: System Settings > Audio Settings > Default Bluetooth Headphone Volume Range: 1 to 15 Default: 11 Sets the default bluetooth headphone jack volume level.
Workout Limits menu	menu: System Settings > Workout Limits Specify the wired and bluetooth headphone default volume levels.
» Maximum Workout Duration	menu: System Settings > Workout Limits > Maximum Workout Duration Range: 1 to 240 min, NO LIMIT Default: 60 min Sets the maximum allowable user workout time per session.
» Maximum Pause	menu: System Settings > Workout Limits > Maximum Pause Range: 1 to 300 sec Default: 30 sec Sets how long the equipment remains in a paused banner during a workout before resetting.
» Summary Time Out	menu: System Settings > Workout Limits > Summary Time Out Sets the time to view the Workout Summary data. Range: 1 to 120 sec Default: 60 sec
» CrossRamp Auto-Level	menu: System Settings > Workout Limits > Summary Time Out Range: 1 - 20 Default: 1

SYSTEM SETTINGS MENU	DESCRIPTION
	Sets the ramp default incline level:
» Maximum Speed	menu: System Settings > Workout Limits > Maximum Speed Default: 12 mph Sets the user maximum speed.
» Maximum Incline	menu: System Settings > Workout Limits > Maximum Incline Default: 15 %
» Auto Stop ⁽¹⁾	menu: System Settings > Workout Limits > Auto Stop Default: ON Sets Auto Stop to On or Off.
Register Equipment menu	menu: System Settings > Register Equipment Register console and equipment with Precor Preva [®] Business Suite "PBS". Required information to register the equipment: <ul style="list-style-type: none"> • Location code • Precor technician account name and password • Serial number from the base • Friendly name assigned to the equipment by the facility (Example: Equipment Type-Floor-Row-Number) To complete registration for Preva-networked facilities: <ol style="list-style-type: none"> 1. Enter the Preva server name (na.preva.com for all sites). 2. Enter the assigned account name and password. 3. Follow the onscreen instructions to register the product.
Manage Settings	menu: System Settings > Manage Settings Save and restore the Connectivity, Display, Media, and Workout Limits settings.

(1) Not available on all models.

System Tests menu

System Tests menu

menu: **Service menu (51765761) > Settings > System Settings > System Tests.**

Machine diagnostics tests to verify system hardware operation.

SYSTEM TESTS MENU	TEST DESCRIPTION
AMT Stride Position Test	<p>(AMT only) menu: System Tests > AMT Stride Position Test Verifies the stride movement:</p> <ul style="list-style-type: none"> • Low Radius. • Hi Radius. • Dynamic Position.
Brake Test	<p>menu: System Tests > Brake Test If the brake is operational, provides the following operating information:</p> <ul style="list-style-type: none"> • PWRB XXX: The current power bits. • RPM: Brake generator RPM. • VBUS XX: Bus Voltage used to drive the brake. • M-AMPS XX: DC brake current.
Battery Test	<p>menu: System Tests > Battery Test Shows the current battery voltage level as "XX.X VDC Y". Where: XX.X is the measured DC battery voltage (nominal 12.6 - 14.6 Vdc). There can be an additional "Y" suffix indicating the following condition: "C" an external AC charger is connected. "L" the battery is low (less than 11.5 Vdc). "CL" charger is connected and the battery is low.</p>
RPM Test	<p>menu: System Tests > RPM Test RPM test:</p> <ul style="list-style-type: none"> • Pulse: current pulse count. • Minimum: minimum pulse count. • Maximum: maximum pulse count.
SPM Test	<p>menu: System Tests > SPM Test (EFX, AMT only) SPM "Strides per Minute" test:</p> <ul style="list-style-type: none"> • Pulse: current pulse count. • Minimum: minimum pulse count. • Maximum: maximum pulse count.
CrossRamp Test	<p>menu: System Tests > CrossRamp Test (EFX, AMT only)</p>

SYSTEM TESTS MENU	TEST DESCRIPTION
	<p>Manually run the lift motor to raise/lower the crossramp through full range, levels 1 to 20.</p> <ul style="list-style-type: none"> • A/D: Lift potentiometer analog to digital voltage value. • Glitches: number of sticking lift motion. • Volts (DC): lift motor voltage.
<p>Auto Stop Test</p>	<p>menu: System Tests > Auto Stop Test</p> <p>Test parameters;</p> <ul style="list-style-type: none"> • Status - User detected on running belt • Step Count - Average # of footplants. Footplant averaging delay reset with each speed change.
<p>Belt Speed Test</p>	<p>menu: System Tests > Belt Speed Test</p> <p>Tests belt operating condition in 0.1 speed increments</p> <p>Test parameters:</p> <ul style="list-style-type: none"> • AMPS IN: Treadmill input Current. • VOLTS IN: Treadmill input Voltage • VBUSS: Treadmill internal buss Voltage • AMPS MTR: Current supplied to the drive motor.
<p>Incline Test</p>	<p>menu: System Tests > Incline Test</p> <p>Test parameters;</p> <ul style="list-style-type: none"> • A/D - lift motor incline position potentiometer A/D number. • SEC - UP/DWN command response delay between the UPCA and LPCA. • Glitches - Momentary failures in the A/D potentiometer output. If there are more than 50 Glitches, the lift motor should be replaced.
<p>USB Test</p>	<p>menu: System Tests > USB Test</p> <p>List the active USB ports.</p>
<p>Touchscreen Test</p>	<p>menu: System Tests > Touchscreen Test</p> <p>Verify touchscreen display.</p>
<p>Touchscreen Calibration</p>	<p>menu: System Tests > Touchscreen Calibration</p> <p>Calibrates touchscreen finger press operation.</p>
<p>Backlight Test</p>	<p>menu: System Tests > Backlight Test</p> <p>Tests the display backlight performance.</p>
<p>RGB Test</p>	<p>menu: System Tests > RGB Test</p> <p>Tests the display color performance.</p>

SYSTEM TESTS MENU	TEST DESCRIPTION
Numeric Backlight Test	menu: System Tests > Numeric Backlight Test Tests the movement controls LCD numeric displays backlight brightness level.
Numeric Display Test	menu: System Tests > Numeric Display Test Tests the movement controls LCD numeric displays.
Heart Rate	menu: System Tests > Heart Rate Test Tests the handlebar unfiltered, filtered, and pulse heart rate. Grasp the grips to test the hand held heart rate. Use a Polar heart rate simulator to test the wireless heart rate. Press the back button to exit this test.
Step Count Reset	(AMT only) menu: System Tests > Step Count Reset Resets the step flat belt usage count. Reset the belt usage count at every step flat belt replacement. <ul style="list-style-type: none"> • Current Total Step Count. • Step Count Resets: number of times the Step Count has been reset. • Odometer Value At Last Reset.

Club Settings Service Menu (5651565)

On P62, P80, and P82 ftuchscreen consoles, Club Settings menu is used by club operators to manage, configure, and maintain the equipment. Service technicians should use the Service menu (51765761) for service and maintenance.

Club Settings Menus

- **About menu**, see "[About menu](#)" on page 51.
- **Equipment Usage menu**, see "[Equipment Usage](#)" on page 53.
- **Maintenance menu**, see "[Maintenance menu](#)" on page 53.
- **System Settings menu**, see "[System Settings menu](#)" on page 55.
- **(No) Available Updates**, see "[\(No\) Available Updates menu](#)" on page 51.

Replacement Procedures

About

There are currently no authorized serviceable electronic parts for the P62 and P82 consoles. If there is a hardware failure, please contact Precor Customer Service (ph. +1 (800) 347-8404) for proper repair disposition.

Available Replacement Procedures

"P82 Console Cover Replacement" on the facing page

"Console Installation and Removal" on page 17

P82 Console Cover Replacement

About

This topic provides instructions to removes and installs the P82 console covers.

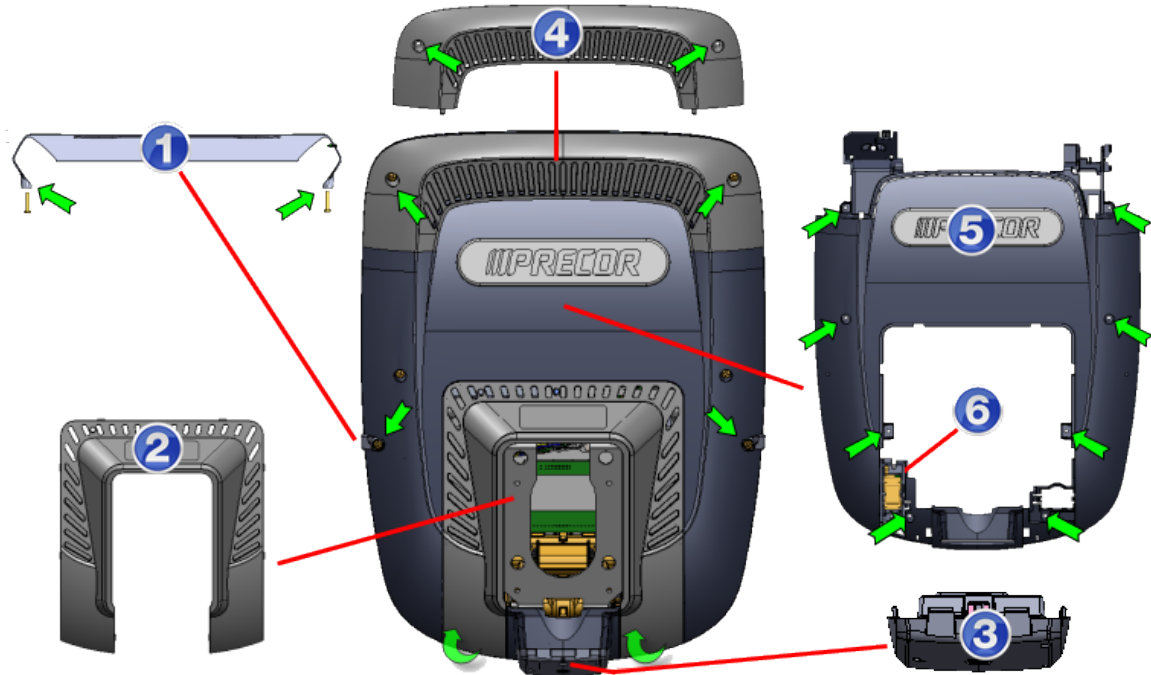

Item	Description
1	Reading Rack
2	Lower Vent Bezel
3	Chin (HP/USB Jack)
4	Upper Access Panel
5	Rear Cover
6	HHR board

Procedure

Review entire procedure before starting.

Removal Instructions

1. Remove the reading rack **1**.
 - a. Remove the two #2 Phillips screw fasteners and carefully lift the reading rack off the front cover. Retain part(s) and/or fastener(s) for installation.
2. Remove the lower vent bezel **2**.
 - a. Use your fingers to carefully unsnap the bottom left and right edges of the bezel from the bottom of the front cover. Then lift the bottom edges up and downward to remove the bezel.
3. Remove the upper access panel **4**.
 - a. Remove the two #2 Phillips screw fasteners and then lift the panel from the front cover.
4. Remove the chin cover (HP/USB jack assembly) **3**.
 - a. Grab the chin and rotate the front side (side with the audio and USB connectors) downward to unsnap the side and rear clips. It does require a small amount of force to unsnap the chin from the back cover.
5. Remove the rear cover **5**.
 - a. Carefully push the HHR board mounting clips outward and lift the HHR board **6** from the clips. Unplug the ground cable (attached to the console weldment).
 - b. Remove the eight #2 Phillips screw rear cover fasteners. Retain part(s) and/or fastener(s) for installation.
 - c. Carefully lift and remove the rear cover while sliding the HHR PCA board through their respective cover openings. Make a note of how the HHR PCA board and chin were routed through the rear cover.

Installation Instructions

1. Install the rear cover **5**.
 - a. Carefully place the rear cover into place onto the back of the console while sliding the HHR PCA board and chin through their respective cover openings.
 - b. Secure using the eight #2 Phillips screw fasteners. Fully tighten the fasteners.
 - c. Carefully install the HHR board **6** into the mounting clips. Then reconnect the ground cable to the HHR PCA board.
2. Install the chin (HP/USB jack assembly) **3**.
 - a. Position the chin so that the front (side with the audio and USB connectors) faces to the console front. Make sure the interface cable is not pinched or damaged. Fit the chin rear mounting clips under the rear cover plastic and then press and rotate the chin so that the side mounting clips snap into place.

3. Install the upper access panel **4**.
 - a. Place the upper access panel onto the front cover and secure using the two #2 Phillips screw fasteners. Fully tighten the fasteners.
4. Install the lower vent bezel **2**.
 - a. Place the bezel over the console weldment so that the bezel top clips fit under the rear cover edge. Then press down near the bottom left and right sides of the bezel to snap the mounting clips into place.
5. Install the reading rack **1**.
 - a. Carefully place the reading rack into place over the front cover aligning the mounting holes. Secure using the two #2 Phillips screw fasteners and fully tighten.

Troubleshooting

About

This section contains troubleshooting information to help you identify, isolate, and resolve component and system issues.

Review the *Introduction To Troubleshooting* section below to learn about the troubleshooting process, troubleshooting best practices, and other pertinent information that will help you efficiently troubleshoot issues and return the equipment to service.

Information that will help you troubleshoot:

- Review the "[Introduction To Troubleshooting](#)" below section below.
- Review the Error Log for active error codes, see the "[CPA Event Log](#)" on page 74 and "[Standard Error Codes](#)" on page 71 topics.
- Refer to the [Error Code Troubleshooting Guide](#) for error code description and troubleshooting repair information.
- If the machine supports the Active Status Light feature, review the ASL topic (see "[Active Status Light \(ASL\)](#)" on page 77).
- Review the System Troubleshooting Procedures topic for possible related issue fixes or repairs, see [System Troubleshooting Procedures](#).

Introduction To Troubleshooting

Troubleshooting issues is an investigative process best implemented utilizing a systematic approach that efficiently targets the issue cause allowing correct equipment repairs and return to service. The following information will help you to systematically troubleshoot and resolve issues.

Basic Steps

Validate the customer reported issue:

The failure that is reported may differ from your observations as a trained technician. Many reported failure are not true failures and can be fixed without a customer visit.

- (powered units only) Always ask the customer if the unit power is connected and switched ON.
- Further interrogate the customer to determine if this is the real issue requiring an on-site visit or possibly a different issue that can be simply resolved over the phone.

Verify the Input Power (Powered units only)

Always begin by verifying the input power cord is connected and the equipment power is switched "ON".

If the unit does not power up or runs poorly, verify the following conditions:

- Make sure there is power at the outlet receptacle and that the power is within the specified voltage and current Limits. If not:
 - The power outlet circuit wire run from the outlet to the circuit panel may be too long causing a large voltage drop.
 - The outlet circuit wire gauge may be too small to carry the required machine load current.
- Make sure that the outlet receptacle power is good quality (the input power is NOT intermittent or has fluctuating voltage levels or frequency). Poor quality input power can cause operational failures.
- Make sure that only one machine is plugged into the outlet receptacle (only one receptacle per outlet receptacle).



IMPORTANT: Always make sure the input power is good quality before troubleshooting the machine. A poor quality input power signal may be the cause of the machine issue or operating failure.

Verify that the console is operating correctly



Note: Keep in mind that if a key on the console keypad does not function, the LPCA will not receive a user initiated request for action. For failed console key problems, the machine failure is not caused by a problem with the LPCA or the machine base, In these types of console failures, no error codes will be triggered and logged.

Review the Error Log or CPA Event Log for any active error codes

Always review the Error Log or CPA Event Log when troubleshooting an issue. The error logs will contain any triggered error code events and related information. You can then refer to [Error Code Troubleshooting Guide](#) to help resolve the issue. Also, when calling Precor customer service for assistance, refer to the Error Log or CPA Event Log for additional information to help the representative resolve the issue.

Refer to the [Error Code Troubleshooting Guide](#) for error code descriptions and repair information.



IMPORTANT: Error code descriptions and troubleshooting information can be found in the *Error Code Troubleshooting Guide*, see [Error Code Guide.pdf](#).



Note: Not all failures trigger an error event code. Many issues are purely mechanical in nature and therefore cannot trigger an error event code.

Verify (reproduce) the issue.

Operate the unit in normal user mode and attempt to reproduce the reported failure. Determine if the error is a repeatable or intermittent type failure. Make note of any additional observations (noises, vibrations, etc.) that occur at the time of the failure which may then be used to help resolve the issue.



Note: It is important to keep in mind that some issues are weight (load) related. You may need to test the unit at minimum and maximum load limits to reproduce the failure.

Perform hardware validation diagnostic tests

Perform the equipment [Hardware Validation Tests](#) (LED consoles) or [System Tests](#) (Touchscreen consoles) to help isolate the cause of the issue. These tests will help identify failed system components. Resolve any resulting failures.

Verify Club Settings

Verify that one of the workout limit settings are not causing a failure, see [Club Settings](#) (LED consoles) or [System Settings Workout Limits](#) (Touchscreen consoles). If a failure is observed while using the machine but passes the hardware validation system tests, this could be an indication that one of the club parameters Limits settings is causing the issue.

Verify that there are no new error codes

After correcting the issue, reopen the Error Log and verify that there are no remaining active error codes. This will verify that the original error codes are not reoccurring and that there are no new error code issues. If the error code is reoccurring, the issue may be mileage related, review the error code odometer history to verify if the error event is related to mileage intervals.



Note: If there is no logged error codes and the issue persists, you will need to use observable and audible indicators to identify the source of the failure. Also make sure that there are no related service bulletins that may resolve the issue. Browse the list of available Troubleshooting procedures for related Troubleshooting information.

Verify service bulletins

Review the list of machine service bulletins and tech-tips and verify that there are no current bulletins that may fix the issue.

Standard Error Codes

About

There is a set of standard error codes implemented across Precor cardio exercise equipment. Error codes are system generated codes that identify specific machine fault conditions. The maintenance software monitors error code event conditions, when a fault is detected, the error code is generated and stored in the Error Log (or CPA Event Log) along with related machine metrics, such as, the machine mileage (or hours), the time, drive motor current, etc.

Error code numbers range from 01 to 99. There are also a small number of alpha and alpha-numeric codes. Most, but not all error codes are grouped into numeric ranges to help easily identify common system issues. Refer to the [Error Code Troubleshooting Guide](#) for a complete list of error codes and troubleshooting information.

IMPORTANT: Error code descriptions and troubleshooting information can be found in the *Error Code Troubleshooting Guide*, see [Error Code Guide.pdf](#).

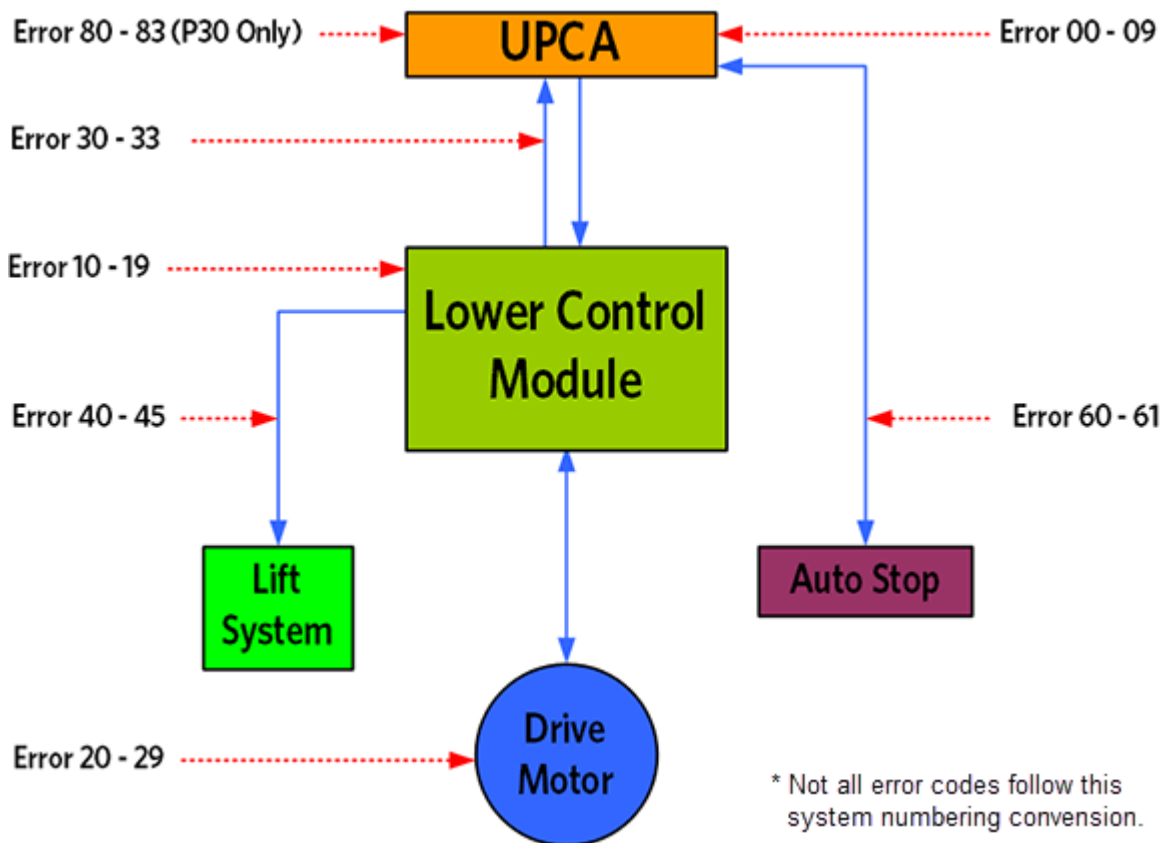

Viewing Error Codes (Error Log & Event Log)

Error event codes are logged, stored, and viewed in either the **Error Log** on LED consoles (P10, P30, P30i and P31) or the **CPA Event Log** on touchscreen consoles (P62, P80, and P82), see [Error Log & CPA Event Log](#).

How to access the Error Log:

- On touchscreen consoles (P62, P80, and P82): access the **Service Settings menu (51765761)** > select **About > CPA Event Log**



TIP: Error codes can be deleted from the Error Log on LED consoles (P10, P30, P30i and P31). Press and hold the **PAUSE/RESET** key for a minimum of 6 seconds to open the Error Log and view all logged error codes. If there are no logged error codes, the "Stuck Key" message will show. To remove error codes, select the error code and press/hold the **QUICK START** key until the "NO ERRORS" message shows.



Note: On touchscreen consoles (P62, P80, and P82)., error codes cannot be deleted from the CPA Event Log (or Error Log).

Error Code and Troubleshooting Guide

Use the *Error Code Troubleshooting Guide* to learn about the error code and to help troubleshoot and repair the machine. The *Error Code Troubleshooting Guide* provides a complete list of all supported error codes and information about the error code including the code description, related issues and symptoms associated with the error, troubleshooting steps, and repair procedures, see [Error Code Troubleshooting Guide](#).

- The error code description.
- The affected system components.
- The Issues and Symptoms associated with the fault condition.
- Troubleshooting steps and repair instructions.

Troubleshooting with Error Codes

Getting Started

You will need a copy of the "*Error Code Troubleshooting Guide*" to learn Information about the error codes including the code description, related issues/symptoms, troubleshooting and repair information, click [Error Code Troubleshooting Guide](#).

Using Error Codes to troubleshoot

1. Review the equipment Error Log (or CPA Event Log) to identify any current active error codes. Also review the error code history for any past error codes that may provide insight to the current active error code issue.
2. Next go to the error code topic in the *Error Code Troubleshooting Guide* and review the error code troubleshooting and repair information.

Note: Be aware that not all machine failures will cause an error code event. Use physical observation and mechanical troubleshooting skills to resolve non error code issues.

CPA Event Log

About

The Error Log is a service maintenance display used to store "log" and view detected error codes. On LED consoles (P10, P30, P30i and P31) you use the "Error Log" to view error codes. However, on touchscreen consoles (P62, P80, and P82) you use the "CPA Event Log" and not the "Event Log" to view error codes.

IMPORTANT: On touchscreen consoles (P62, P80, and P82), use the **CPA Event Log** and not the **Event Log** to view maintenance error codes. The Event Log includes additional error codes that are not included in the *Error Code Troubleshooting Guide*.

The maintenance software monitors error code event conditions, when a fault is detected, the error code is generated and stored in the Error Log (or CPA Event Log) along with related machine metrics, such as, the machine mileage (or hours), the time, the drive motor current when applicable, etc.

Error event codes are sequentially stored as a table in memory on a First-In Last-Out basis, the newest error code is stored in the number one position pushing any stored error codes down one position. When the memory is full, the next code is stored pushing the oldest error code from the table removing it from memory.

Special circumstances (repeating errors)

When an error event is detected, the error code information will be stored into the error log. However, when multiple instances of the same error code event occur within the same hour or odometer reading, only the first occurrence will be logged. One of the following conditions must occur to cause a repeating error code to be subsequently logged:

- the elapsed time must exceed one hour from the first occurrence
- or the odometer mileage must change from the first occurrence
- or a different intervening error code is logged

Note: Multiple repeating instances of the same error code event occurring during the same hour or odometer reading will only be logged as a single error code event.

Troubleshooting

Always review the Error Log or CPA Event Log when troubleshooting an issue. The error logs will contain any triggered error code events and related information. You can then refer to the *Error Code Troubleshooting Guide* error code topic to help resolve the issue. Also, when calling Precor customer service for assistance, refer to the Error Log or CPA Event Log for additional information to help the representative resolve the issue.

Note: Be aware that not all machine failures will cause an error code event. Use physical observation and mechanical troubleshooting skills to resolve non error code issues.

On LED consoles (P10, P30, P30i and P31), error codes are viewed on the **Error Log**.

- Access the service **Information Display (65)** > select **Error Log**.

Understanding Error Codes

Touchscreen Console (P62, P80, and P82) CPA Event Log

On touchscreen consoles (P62, P80, and P82) you will use the CPA Event Log to view error codes and not the Event Log.

- Access the **Service Settings menu (51765761)** > select **About > CPA Event Log**

Understanding Error Codes

Each logged machine error code will be shown on the CPA Event Log menu. Use the touch-screen vertical scrollbar to scroll up/down thru the list of error codes.

The P62, P80, and P82 CPA Event Log provides the same error code data found in the P10, P30, P30i and P31 Error Log in addition to the event date & time stamp information. The "CPA ERROR" identifier in the error code output message indicates that this is a machine fault error code that can be used along with the *Error Code Troubleshooting Guide* to help resolve the issue.

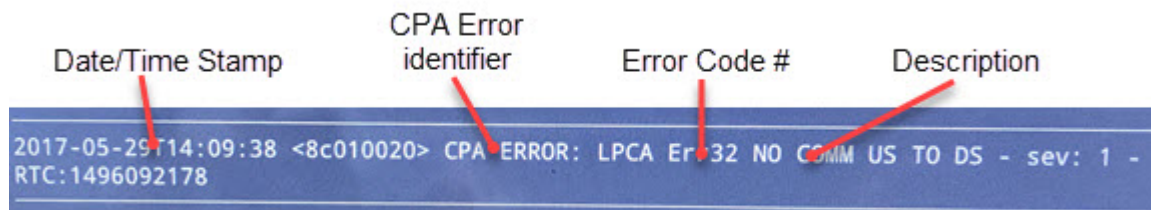

CPA Event Log - error code message

Typical CPA Event Log data:

- Error Code Data
 - Event Time & Date Stamp
 - [Error Code](#) Number
 - [Error Code](#) Description
 - Odometer
 - Hours
 - Motor Current*
 - .Input Line Current*
 - Input line voltage*
 - Buss Voltage*
 - OEM Factory only data

Note: * machine dependent parameter.

Removing Error Codes

Unlike the Error Log used on LED consoles (P10, P30, P30i and P31), you cannot manually delete (clear) error codes from the touchscreen console (P62, P80, and P82) CPA Event Log or the Event Log.

Note: On touchscreen consoles (P62, P80, and P82), error codes cannot be deleted from the CPA Event Log or the Event log.

Active Status Light (ASL)

(Only applies to machines that support the ASL feature)

About

The Active Status Light (ASL) is a service and maintenance status light that provides a visual indication of the machine operational status. The current implementation supports four states: 1) Solid blue - indicates normal operation, 2) pulsing blue - indicates preventative maintenance is required; 3) Solid yellow - indicates an error has occurred but the machine is useable; and 4) pulsing yellow - indicates a loss of major function was detected.

The console can be used to control the ASL functions including, settings the light brightness level, viewing the ASL state, resetting the ASL states, enable/disable the maintenance reminder, and viewing the maintenance due remaining mileage (or hours), see "" on page 80.

ASL Light Equipment Location

On treadmills, the Active Status Light (ASL) is a service and maintenance status light located on the front lower center of the front hood cover.

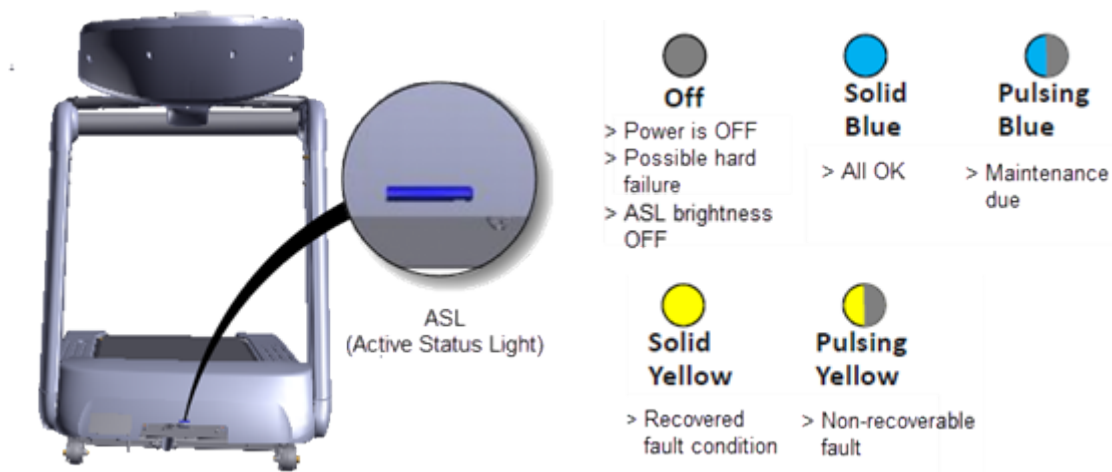

On Ellipticals, the ASL light is located at the rear of the unit on the lower right side of the right drive housing cover. The ASL also functions as the ASL "Wakeup" switch used to temporarily power-on the ASL and as a shortcut method to clear error states. .

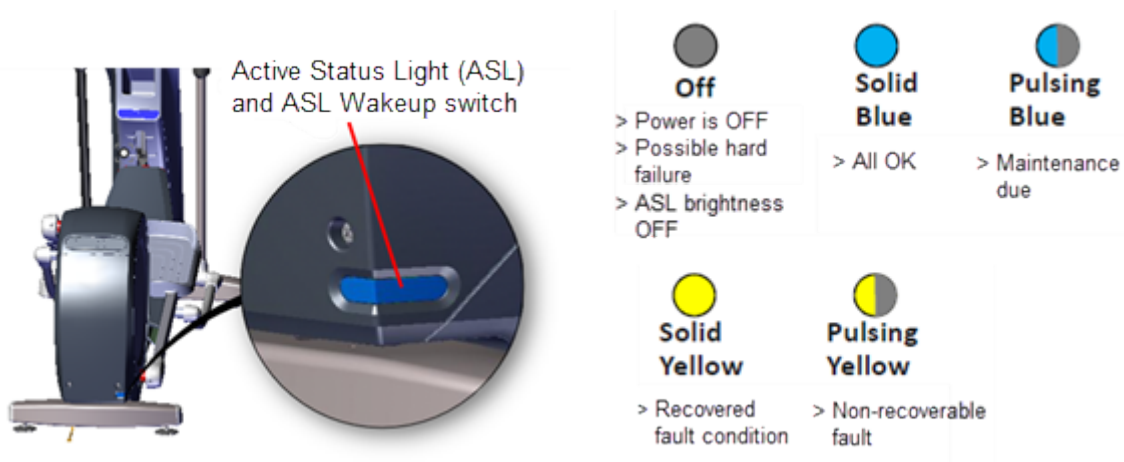

ASL Overview





- An externally visible indicator of the current machine operational status. There are four supported states: 1) solid blue - indicates normal operation, 2) pulsing blue - indicates preventative maintenance is required; 3) solid yellow - indicates an error has occurred but the machine is useable; and 4) pulsing yellow - indicates a loss of major function was detected.
- When either the exerciser starts pedaling or when the ASL Wakeup switch (ASL light cover) is pressed, the ASL light will power-on and start indicating the current machine ASL status. The ASL light will remain ON while the machine is being used (pedaled) and will switch OFF after 90 seconds of non-use (no pedaling).
- Because only one status color and state can be shown at a time, the condition states are prioritized as follows from lowest to highest: Blue Solid (lowest), Blue Pulsing, Yellow Solid, Yellow Pulsing (highest). Higher priority states are always shown before a lower priority state, until cleared.
- The console UPCA determines the ASL state using inputs from the error log and maintenance counter. During active operation (workout in progress) or during the pause state, the console transmits the ASL state to the lower control board (LPCA).
- Only direct error code and maintenance counter data is used to determine the current machine ASL state. No special algorithms (e.g., user behavior) are utilized to determine the status.
- Similar to other self-powered products, the lower control board (LPCA) powers OFF between workouts. The power-on and power-off of the ASL are under control of the LPCA at all times. The console cannot control power-on or power-off. The LPCA powers ON when the user pedals above the minimum RPM and for one minute after stopping, and powers ON for 90 seconds when the Wakeup switch is pressed.
- Error code operation: A logged system error code will cause the ASL to begin pulsing yellow. If the error self-corrects, the ASL will change from pulsing to solid yellow. Depending on the error code type, after the end of a workout, the solid yellow light will

either revert back to blue (or pulsing blue), or require the operator to do a manual reset from the service menu.

- Maintenance counter operation: The counter starts at 1000 miles and counts down the miles of active use to 0 miles. When the counter reaches zero, the ASL will begin pulsing blue indicating preventative maintenance is due.
- Maintenance counter operation: The counter starts at 250 hours and counts down the hours of active use to 0 hours. When the counter reaches zero, the ASL will begin pulsing blue indicating preventative maintenance is due.
- Viewing the ASL light
 - When in active use with exerciser striding.
 - When the exerciser presses the Wakeup switch located on the rear of the unit.
 - For 90 seconds after the exerciser ceases striding.
 - For 90 seconds after the Wakeup switch is pressed.

ASL States

The ASL utilizes a combination of blue and yellow lights to indicate the current operational machine status.

 Off	 Solid Blue	 Pulsing Blue	 Solid Yellow	 Pulsing Yellow
<ul style="list-style-type: none"> > Power is OFF > Possible hard failure > ASL brightness OFF 	<ul style="list-style-type: none"> > All OK 	<ul style="list-style-type: none"> > Maintenance due 	<ul style="list-style-type: none"> > Recovered fault condition 	<ul style="list-style-type: none"> > Non-recoverable fault

ASL State	DESCRIPTION
OFF	The unit is powered OFF or there is no power to the LPCA or some other hard failure. On P10, P30, P30i and P31 consoles the ASL brightness is set to OFF.
Blue Solid	Normal operation Indicates that the ASL has not detected any logged error codes.
Blue Pulsing	Preventative maintenance reminder. Treadmills: A belt rating of 0 or 1 will cause a blue pulsing ASL light indicating that there is a problem with the running belt/deck and is in need of servicing or replacement.

ASL State	DESCRIPTION
	Ellipticals: The maintenance counter starts at 1000 hours and counts down the active use hours to 0. When the counter reaches zero hours, the ASL will begin pulsing blue indicating preventative maintenance is due.
Yellow Solid	Indicates an error has occurred, was self-corrected and the machine can be used. The fault can be cleared.
Yellow Pulsing	There is a current non-recoverable fault condition, there is a loss of a major function and the machine is out-of-service. Machine service is required.

ASL Settings and Functions

Setting the ASL light brightness level

The ASL Light Brightness level settings are HIGH, MEDIUM, and LOW. On P10, P30, P30i and P31 consoles, the light brightness level can be switched OFF.

- On P10, P30, P30i and P31 consoles, the OFF setting switches the ASL light brightness OFF for all ASL state conditions. Setting the ASL Light Brightness OFF only switches the ASL light brightness OFF and not the ASL active status functionality.
- Regardless of the brightness level setting (including OFF), you can view the current ASL state (blue, yellow, etc.) in the service access menus, see "[Viewing the current ASL state](#)" on the facing page.

P62, P80, and P82 consoles:

Access **Hardware Validation** (51765761) > **Maintenance** menu > **AS LIGHT BRIGHTNESS** > select **HIGH, MED, or LOW**.

Disabling the ASL Maintenance Reminder

When set to ON, the ASL maintenance reminder - pulsing blue light state is triggered ON when the maintenance counter counts down to zero miles (or zero hours). When set to OFF, the ASL Maintenance Reminder counter is ignored and the ASL state is not changed to pulsing blue.

- The "OFF" setting effectively disables the ASL "blue pulsing" state without affecting the yellow or pulsing yellow fault states.
- When set to OFF, the Maintenance Reminder counter continues counting down the miles (or hours) remaining which can be viewed in the service access menu, see "[Viewing the current ASL state](#)" on the facing page.

- Error code events will still affect the ASL state condition even when the Maintenance Reminder is set to OFF.

P62, P80, and P82 consoles:

Access **Club Settings** (5651565) > **Maintenance** menu > **Maintenance Reminder** > select **ON** or **OFF**.

Viewing the current ASL state

The current ASL state (solid blue, pulsing blue, solid yellow; or pulsing yellow) can be viewed using the service menu **ACTIVE STATUS LIGHT** parameter.

P62, P80, and P82 consoles:

Access **Club Settings** (5651565) > **Maintenance** menu > **ACTIVE STATUS LIGHT** > current ASL state.

Viewing the ASL maintenance counter remaining miles (or hours)

P62, P80, and P82 consoles:

Access **Service Software** (51765761) > **Maintenance** menu > **Next Maintenance Due**

The maintenance counter shows the remaining miles (or hours) until the machine maintenance is due. Reaching zero triggers the ASL pulsing blue "maintenance due" state.

Clearing the Blue Pulsing ASL State (Maintenance Counter reset)

Resetting the maintenance counter clears the blue pulsing ASL state and sets the ASL state to solid blue. The maintenance counter is also reset to the default value (treadmills reset to 1000 miles, ellipticals reset to 250 Hrs).

P62, P80, and P82 consoles:

1. Access **Service Settings** (51765761) > **Maintenance** menu.
2. Select **Next Maintenance Due** > **Reset**.

Clearing the Yellow & Yellow Pulsing ASL states

An ASL pulsing yellow state is triggered when an error code event occurs and is logged. To clear a pulsing yellow state, the error condition causing the ASL pulsing yellow must first be resolved either manually or the machine may resolve and self-clear the issue. A manually or machine self-cleared error code will change the ASL state from pulsing yellow to the solid yellow state.

Clearing the pulsing yellow ASL state

An ASL pulsing yellow state is triggered when an error code event occurs and is logged. To clear a pulsing yellow state, the error condition causing the ASL pulsing yellow must first be resolved either manually or the machine may resolve and self-clear the issue. A manually or machine self-cleared error code will change the ASL state from pulsing yellow to the solid yellow state.

Clearing the solid yellow ASL state

P62, P80, and P82 consoles:

1. On P62, P80, and P82 consoles, the **Maintenance > Operating Condition** parameter must be reset from the **Inspect** condition to the **Normal** condition. After resetting the Operating Condition to Normal, the ASL state will change from solid yellow to the solid blue state.
2. Then go to the **CPA Event Log** and clear the error code by selecting the **Clear** control.



Note: Clearing the CPA Event Log does NOT clear the error codes from the Event Log.

Preventive Maintenance

About

Preventative maintenance is proven to extend the life of the equipment, improve the user experience, and keep maintenance problems and service calls to a minimum. Precor recommends the following preventative maintenance schedule.



IMPORTANT: It is the responsibility of the owner to maintain equipment in accordance with the Precor recommended preventative maintenance schedule. Following the preventative maintenance schedule is required to maintain warranty coverage.

Additional Services

Precor offers a subscription Preventative Maintenance Program, see [Preventative Maintenance Program](#).

Maintenance Schedule

The preventative maintenance tasks should be performed on a daily basis,



IMPORTANT: If you determine that the console needs service, disconnect all power connections (television, Ethernet, and input power). Place an OUT OF SERVICE sign on the equipment and make it clear to all patrons and other users that they must not use it.

Daily Task	Instruction
Clean the consoles.	Clean the console plastic covers with a damp lint free cloth using water or approved cleaner, see " General Information " on page 5. Dry completely. Clean the touch-screen display with a damp lint free cloth using ONLY a diluted solution of one part 91% Isopropyl Alcohol to one part water.
Check motion controls.	Start a workout and verify the motion controls have smooth movement and control the motion functions.
Check I/O cables	Make sure that power cables and interface cables are not tangled, pinched, or disconnected.

Parts

About

The following copies of the equipment "*Exploded View Diagram*" and "*Parts List*" are provided for you to use as a quick reference.

It is recommended that you go to the Precor Partner Website, [Precor Connect](#), to view the most current *Exploded View Diagram* and *Parts Identification List* information.

- [Precor Partner Website](#)

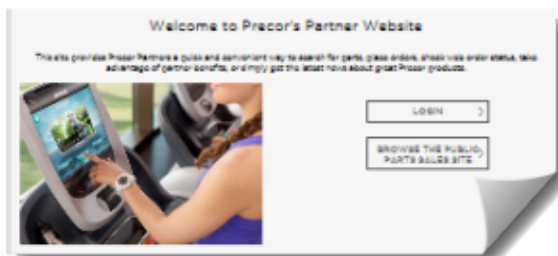

IMPORTANT: Always purchase OEM replacement parts and hardware from Precor. If you use parts not approved by Precor, you could void the Precor Limited Warranty. Use of parts not approved by Precor may cause injury.

P82 Console Parts

P82 - Exploded View Diagram

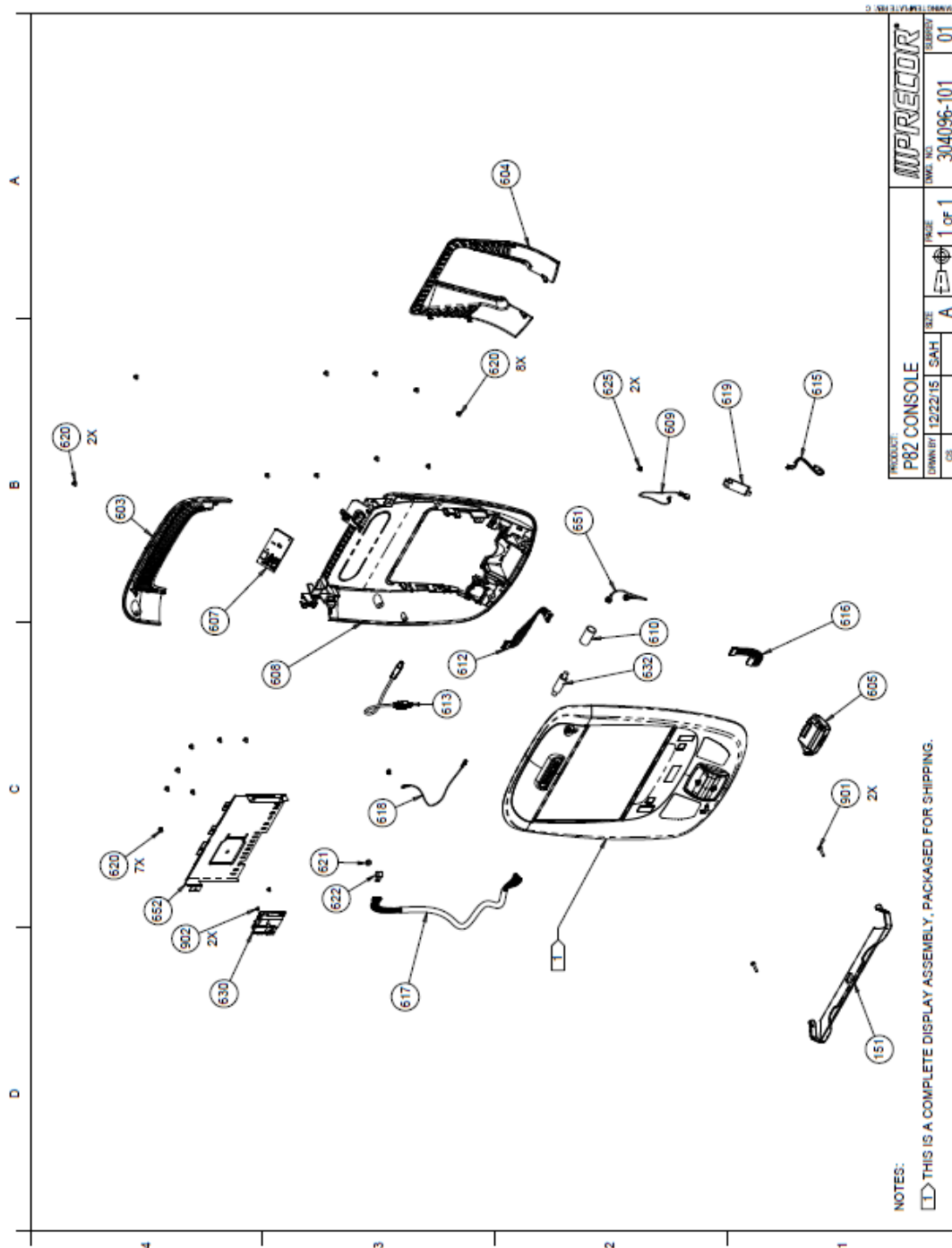

P82 - Parts List

SAP Material #	Item Description	Bubble Numbers
PPP000000302038101	PLUNGER, POWER RESET	67
PPP000000303260103	PLASTIC,RACK,READING/DEVICE, BLACK, P82	151
PPP000000303348112	ASSY,TUNER MODULE, EXETER2 NORTH AMERICA,P82	602
PPP000000300303104	PLASTIC,ACCESS PANEL,UPPER,DISPLAY,TWILIGHT	603
PPP000000303264106	ASSY,BEZEL,LOWER VENT,DISPLAY,P82,W/ PRINT	604
PPP000000303360103	ASSY,HP AND USB JACK,P82	605
PPP000000303750101	MODULE, NFC, P82	607
PPP000000303263104	ASSEMBLY, PLASTIC, REAR, DISPLAY, P82	608
PPP000000040151008	ASSY,CBL,8C,1 CTR,1-1,4 TW PR,W/RAMP & RIBS,SN,8"	612
PPP000000012478012	ASSY,CBL,USB 2.0, A MALE/B MALE,BLACK,12"	613
PPP000000040152007	ASSY,CBL,3C,.1 CTR,W/RAMP & RIBS,1-1,SN,7"	615
PPP000000040011004	ASSY,CBL,8C,.1 CTR,1-1,SN,4"	616
PPP000000303747020	ASSY,CBL,20P20C USB, TWISTED PAIR,HEATSHRINK,20"	617
PPP000000040010008	ASSY,CBL,1C,20AWG,#8 RING/.110X032 QD RECP,BLACK,(8")	618
PPP000000300812101	BOARD,CHR & WIRELESS,SALUTRON,(PORTRAIT),100R	619
PPP00000MGCN016025	SCREW,PAN HD PHIL,8-32 X .25,STL,CLR ZN	620
PPP00000KECN019014	NUT,LOCK,FULL,10-32,NYLON INSERT,STL,CLR ZN	621
PPP000000012865003	CABLE P-CLIP,OPEN ENDED,0.375" BUNDLE	622
PPP00000KLCN019012	NUT,LOCK,10-32,KEPS,STAR WASHER,SSTL,CLR ZN	623
PPP000000012297024	TAPE,3M VHB 4956,0,062"TH ,0.375"W,GRAY	626
PPP000000303270102	BRACKET,SERVICE,P82	652
PPP00000MGCN011025	SCREW,PAN HD PHIL,4-40 X .25,STL,CLR ZN	902

P62 Console Parts

P62 - Exploded View Diagram

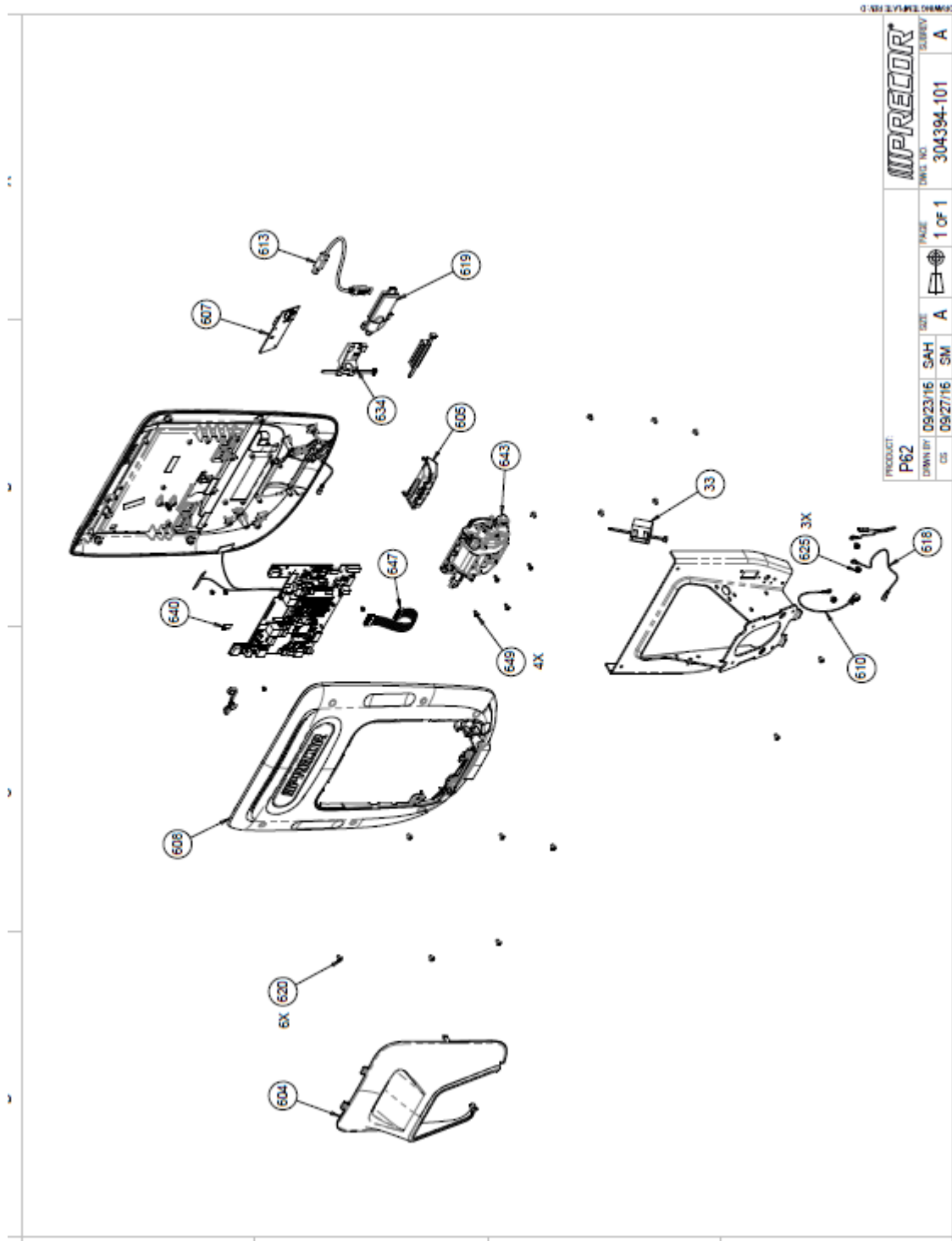

P62 Parts List

Part Number	Item Description
PPP000000300812101	BOARD,CHR & WIRELESS,SALUTRON,(PORTRAIT),100R
PPP000000302038101	PLUNGER, POWER RESET
PPP000000303908104	PLASTIC, ACCESS PANEL, P62
PPP000000303360103	ASSY,HP AND USB JACK,P82/P62
PPP000000304232101	MODULE, NFC, P62
PPP000000303906102	ASSY, REAR PLASTIC + BADGE
PPP000000301415008	CBL,1C,20AWG,#8 RING/250X032 QD RECP,BLK,8"
PPP000000012478012	ASSY,CBL,USB 2.0, A MALE/B MALE,BLACK,12"
PPP0000000040152007	ASSY,CBL,3C,.1 CTR,W/RAMP & RIBS,1-1,SN,7"
PPP000000304404008	ASSY,CBL,20P12C USB,HEATSHRINK,8"
PPP000000040010008	ASSY,CBL,1C,20AWG,#8 RING/.110X032 QD RECP,BLACK,(8")
PPP000000303940101	ASSY, TUNER + COAX ISOLATOR, P62
PPP000000MGCN016025	SCREW,PAN HD PHIL,8-32 X .25,STL,CLR ZN
PPP000000DECN016025	SCREW,PAN HD PHIL,8-32 X .25,SEMS,STAR WASHER,STL,CLR ZN
PPP000000303944101	PLASTIC, ISOLATOR MOUNT,P62
PPP000000013424016	MEMORY CARD,MICROSDHC,CLASS 10,16GB
PPP000000300350110	ASSY,MACHINE CONTROL,(DOUBLE, BLACK)
PPP000000040011006	ASSY,CBL,8C,.1 CTR,1-1,SN,6"
PPP000000PARCN013038	SCREW,SELF-TAP,TRI,PAN HD PHIL,6 X .375,PLASTITE,STL,CLR ZN
PPP000000MGCN011025	SCREW,PAN HD PHIL,4-40 X .25,STL,CLR ZN

Appendix A : Edition Information

Edition

Title: P82 Console Service Manual

P/N: 20039-181

Publish Date: May 2019

Additional Documentation

You can also view the service manual online at  [Online Service Manual](#)

Copyright

Copyright 2016 Precor Incorporated

No part of this manual may be reproduced in any form or by any means (including electronic storage and retrieval or translation into a foreign language) without prior agreement and written consent from Precor Incorporated as governed by United States and international copyright laws.

Precor Incorporated
20031 142nd Ave. NE
P.O.Box 7202
Woodinville, WA. 98072-4002
Ph: 1-800-347-4404

Appendix B : Notices and Safety

Trademarks

Precor, AMT, EFX, and Preva are registered trademarks of Precor Incorporated. Other names in this document may be the trademarks or registered trademarks of their respective owners.

The Spinner Family of bikes—Spin®, Spinner®, Spinning®, Spin Fitness®, and the Spinning logo® are registered trademarks owned by Mad Dogg Athletics, Inc., a California corporation.

SPD is a registered trademark of Shimano American Corporation.

Intellectual Property

All rights, title, and interests in and to the software of the Preva Business Suite, the accompanying printed materials, any copies of such software, and all data collected via the Preva Business Suite, are exclusively owned by Precor or its suppliers, as the case may be.

Precor is widely recognized for its innovative, award-winning designs of exercise equipment. Precor aggressively seeks U.S. and foreign patents for both the mechanical construction and the visual aspects of its product design. Any party contemplating the use of Precor product designs is hereby forewarned that Precor considers the unauthorized appropriation of its proprietary rights to be a very serious matter. Precor will vigorously pursue all unauthorized appropriation of its proprietary rights.

Warranty

The material contained in this document is provided "as is," and is subject to being changed, without notice, in future editions. Further, to the maximum extent permitted by applicable law, Precor disclaims all warranties, either expressed or implied, with regard to this manual and any information contained herein, including but not limited to the implied warranties of merchantability and fitness for a particular purpose. Precor shall not be liable for errors or for incidental or consequential damages in connection with the furnishing, use, or performance of this document or of any information contained herein. Should Precor and the user have a separate written agreement with warranty terms covering the material in this document that conflict with these terms, the warranty terms in the separate agreement shall control.

Safety Notices

Warning and Caution notices indicate an activity that could be dangerous and cause personal injury and/or equipment damage if not adhered to. Always follow Warning and Caution instructions.

Warning



A **WARNING** notice denotes a hazard. It calls attention to an operating procedure, practice, or the like that, if not correctly performed or adhered to, could result in personal injury or death. Do not proceed beyond a WARNING notice until the indicated

conditions are fully understood.

Caution



A **CAUTION** notice denotes a hazard. It calls attention to an operating procedure, practice, or the like that, if not correctly performed or adhered to, could result in damage to the product or loss of important data. Do not proceed beyond a CAUTION notice until the indicated conditions are fully understood.

Service Safety Guidelines

Prior to doing any machine service, review the Service Safety Guidelines, see [Service Safety Guidelines](#).