

marko

foam products, inc.

2023 BLANK CATALOG

MARKOFOAMBLANKS.COM

TABLE OF CONTENTS

GENERAL INFO..... 2

AS SEEN IN..... 6

Q & A 8

FOAM TYPES 11

STRINGER OPTIONS 14

BLANK CATALOG16

SUP CATALOG 52

GENERAL INFO

CONTACT

MARKO FOAM BLANKS HQ
7441 Vincent Circle
Huntington Beach, CA 926dgd
(949) 417-3307
ORDER@MARKOFOAM.COM

WHOLESALE ACCOUNT SET-UP (FOR BUSINESSES ONLY)

Email business license and reseller ID to order@markofoam.com

RETAIL

If you are not a business, you can purchase our products from any of our distributors or from our online store.

DELIVERY METHOD AND SCHEDULE

Marko Foam delivers direct in California from our Irvine based factory. Our blanks are available to all other locations via box shipments, pallet shipments, or container loads.

DELIVERY TYPE	METHOD	LOCATION	QUANTITY
Direct	Marko Truck	San Diego to San Francisco	5-300
Box	Common Carrier	Worldwide	4-5 / BOX
Pallet	Freight Truck	Continental US	Approx. 50
Container	Freigh Truck + Ship	Worldwide	400-800

SHIPPING AND RETURNS

SURFBOARD BLANK SHIPPING

If you are out of our trucks delivery route we can easily ship to your location. We can pack up to four surfboard blanks or CNC cuts of any combination into a single box for shipping to your location. If you would like to get a shipping quote please contact us at order@markofoam.com with what you would like to order as well as your shipping address and we will get back to you ASAP. We do recommend using a commercial address if possible as it will save you on shipping fees.

SUP BLANK SHIPPING

If you are out of our trucks delivery route we can easily ship to your location. We up to can fit three surf SUP blanks/cuts or two race SUP or prone paddle blanks/cuts into a single box. If you would like to get a shipping quote please contact us at order@markofoam.com with what you would like to order as well as your shipping address and we will get back to you ASAP. We do recommend using a commercial address if possible as it will save you on shipping fees.

BULK ORDERING (21+ BLANKS UP TO 8' LONG)

If you are looking to order more than five boxes of blanks, 21+ blanks, we can also palletize up to 50 blanks up to 8' in length. This usually makes for cheaper shipping costs per blank. Unfortunately, this option does not apply for CNC cuts at this time. If you would like to get a shipping quote, please contact us at order@markofoam.com with what you would like to order as well as your shipping address and we will get back to you ASAP. We do recommend using a commercial address if possible as it will you save on shipping fees

BOXING/PALLETIZING FEES

Surfboard Blanks/Cuts- \$25.00 covers the box and labor to pack a single box (up blanks/cuts) any additional boxes that are needed will be an additional \$25.00 per box.

SUP Blanks/Cuts-\$50.00 covers the box and labor to pack a single box (up to 3 blanks/cuts) any additional boxes that are needed will be an additional \$50.00 per

BULK ORDER- \$50.00 covers the pallet and labor to load a single pallet (up to 50 blanks) any additional pallets or blanks over 8' in length will have additional boxes and costs.

UPON ARRIVAL OF SHIPMENT...

Someone **MUST** be available to accept your order. If you give permission to shipping company to leave the box without someone to inspect and sign for it, insurance on the shipment is voided. **DO NOT** decline the shipment and/or send as it complicates the claim and voids the insurance as well. **Please inspect the and its contents thoroughly at the time of delivery.** If you find that any part of order is damaged, or if the box itself is damaged, have the driver notate it on the lading and **take pictures of the damaged goods and box.** Contact us as soon as can with pictures at info@markofoam.com and explain the damages and we initiate the claim immediately. Upon receipt of your information we will ship out replacement(s) with no additional shipping charges to the customer. Please hold the packaging and damaged goods for two weeks in case the shipping company to do further inspection. Everything ordered with Marko Foam is insured for the amount.

PAYMENT TERMS

WHOLESALE

Initial orders are either prepayment or C.O.D. All container orders require 50% deposit and final 50% is due prior to shipping. Credit terms are considered only after a client relationship has been established. Once relationship is established client will fill submit credit form. A finance charge of 24% APR is applied to past due balances.

ONLINE

All online orders require full payment up front. We accept all credit and debit cards.

PICK UP

All pick up orders are either prepayment or C.O.D. We accept cash, check or all major credit cards.

GUARANTEE

Marko Foam guarantees the quality of our blanks. If you receive a blank that does not meet our quality standards, we will replace the blank. In addition, if that blank has been shaped, we will credit the customer with a shaping fee (per our schedule) OR an additional blank (to be determined by Marko Foam). In order to be eligible for either credit, the inferior blank must be returned to Marko Foam.

SUSTAINABILITY

At Marko Foam, our recycling and sustainability initiatives are a top priority. At all of our facilities we believe in zero waste. We make sure all scraps and dust from both our facilities are collected, recycled and repurposed back into our products. Not only do we recycle our waste but we are an EPS Industry approved foam collection facility. This allows anyone to drop off their EPS trash to be recycled. All collected foam is collected, grinded, melted down and reused back into our foam product line.

Our Waste to Waves Program in collaboration with Sustainable Surf has been given both national and international recognition. Thanks to our W2W surf shop partners, we are able to collect consumer EPS foam waste from their collection boxes. We take that EPS waste to recycle, process and repurpose the foam into all of our foam products not just surfboards.

MARKETING

Marketing resources (listed below) are available for free to our wholesale customers. Our goal is to educate our customers and surfers a like on our foam technologies, the importance of using quality foam and our current position as the only eco-board approved foam on the market.

- Blank Catalog
- T-Shirts
- Lams
- Stickers

AS
SEEN IN



"Marko is Album's only source for EPS. Best cell structure, feel & performance hands down and the best crew to work with!"

- Matt Parker, Album Surfboards

"Marko Foam not only makes great EPS, but also provides outstanding customer service and insight that allows me to make a better surfboard."

- Jon Pyzel, Pyzel Surfboards

"I have been using Marko exclusively for EPS for 17 years. Their quality service and dependability on their product is unmatched in this industry."

- David Vernor, Vernor Surfboards

Q & A

Marko Foam Blanks

Location: Huntington Beach, CA-USA

1/ Genesis of the factory

Marko was founded in 1959 by Don Peterson as a family owned & operated foam manufacturing and fabrication facility. Today, Marko has three generations of the Peterson family working, including the Founder Don Peterson.

In 2006 Marko took decades of knowledge molding EPS foam and started a specialized line of EPS surfboard blanks. Marko wanted to prove that EPS is a viable option for building high quality surfboards.

Marko has continued to grow their blank line by working with some of the best board builders in the world including William Stretch "Riedell of Stretch Surfboards and Matt Mayhem" Biolos of Lost Surfboards. This has allowed them to test the limits on what material and construction methods a high-performance surfboard can be built from by being ridden by some of the best surfers in the world.

3/ What is your product line ?

Marko has a full collection of water sport related foam blanks including wake surfs, body boards, surfboards and SUPs.

4/ Benefits of Marko's MOLDED EPS Blanks

Marko prides itself on the quality of their products. Marko uses a proprietary molding technique when making their blanks. This enables them to:

- Have consistent densities throughout their blanks.
- High fusion between beads making for a better finish when shaping and overall stronger board.
- High durability factors means longer board life and better investment over time.
- 100% recyclable material and safer to use for your health.



PREMIUM BLANKS MADE IN USA

2/ EPS / PU?

Marko Foam is an EPS surfboard blank manufacturer that uses unique form molding techniques to ensure the tightest bead fusion, cleanest finish and the best performance possible in a finished surfboard. Meaning the foam is more durable because of tight fusion, safer to shape due to lack of chemicals and better performing because of its balanced densities. EPS foam is known for its recyclable qualities. Marko recycles over 150,000 lbs a year.

5/ How are blanks produced?

Each Marko blank is molded in an aluminum mold that is also manufactured by Marko Foam. They use a proprietary bead type that is pre-expanded to a precise density before it is injected into the mold. Steam is used to build up pressure inside the cavity to fuse the beads together. The molding process and bead type that is used enables Marko to create very tight fusion between the beads making for a smoother finish for shaping and overall stronger board.

6/ About different densities and uses?

The density of a blank can greatly effect the weight and flex of a board. EPS is known for being lighter than PU boards but that is only if you want it to be. If you increase the density of the blank you can match the weight and overall buoyancy of a PU board. With higher densities you also create more crush resistance and increase overall strength so heavier glassjobs are not necessary. Without a heavy glass job, you will create more flex in the board.

7/ About stringers: How to choose the right one?

The type of stringer you use can greatly effect the flex and feel of your board. Softer stringers, such as Cedar are going to flex more. While a harder wood like bamboo will absorb a lot of the vibration that can be felt while riding a wave and stiffen the board which is great for big wave boards.

With new construction methods being developed, new types of stringers such as high density EPS, PU and other composite materials have emerged. These can greatly change the flex pattern of boards depending on what type of glass jobs they are combined with. The testing of these products are still underway but have had promising feedback from those who have tried it.

8/ What's new in your future ? Next product evolution?

We are constantly pushing to make the highest quality blanks possible. We recently launched a new formula for our blanks that has superior fusion between the beads which makes for a better shaping experience and overall stronger board. We also have a new line of blanks that will truly revolutionize the industry and set them apart from other blank companies when released. We are ready as anybody to take on the ever changing landscape of the surfboard building community, the question is not what can we do but what can't we do.



FOAM TYPES

FOAM TYPES

VIRGIN FOAM

The virgin surfboard blank is our staple product that has been in production since day one. This blank is made out of our newest EPS formula. This formula has the ability to be completely recycled.

BENEFITS TO THE VIRGIN FOAM:

Stronger board due to tight fusion between the beads. Cleaner look Easier to shape because the tightly fused beads that do not fall apart.

I-FOAM

I-foam is a highly durable copolymer material that we developed for high-performance water sports as seen in many soft boards and body boards. We brought this high-tech, lively core to the surfing public to enjoy back in the 80's. The I-Foam core has been shaped and tested in all kinds of surfing conditions to ensure the highest quality water sport foam blank is made.

BENEFITS OF I-FOAM:

No water absorption due to its closed cell material that is fused tightly together. Highly durable due to the incredible strength of the epoxy glassing and resiliency of the I-Foam material. High performance due to the memory of the I-Foam allows the rider to rebound and glide into turns easier.

*Available on select blank models



Density Chart

Blank Description	VIRGIN EPS			I-FOAM					
	1.7lb	2.0lb	2.3lb	1.7lb	2.0lb	2.3lb			
MOLDED BLANKS									
Wakesurf Regular		X							
5'3 Foil	X								
6'0 M Regular		X							
6'0" M Thick	X	X	X						
6'1 Pescado		X							
62 H New		X							
6'2 Thick		X							
6'4 TP		X							
6'4 Thick	X	X	X						
6'6 M	X	X	X		X				
6'8 JJ		X							
6'9 Regular		X							
6'9 Thick	X	X	X						
7'2 M Regular	X	X	X						
7'2 M Thick		X							
7'4 Halibut		X							
7'5 Machin All		X							
7'6 JJ		X							
7'6 Thick		X							
8'5 Universal		X							
8'5 Machinal all	X	X	X						
9'1 JJ		X							
9'1 Machine All	X	X	X		X				
BLOCK CUT	1.0#	2#	2.5#	Gun Blanks: Our Gun Blanks are available in 2.0# and 2.5# densities up to 12' and are Block cut.					
MK 9'6		X	X	SUP Blanks: Our SUP blanks are available in 1.5# up to 12'0" and 1.0# up to 18'0" and are Block cut.					
MK 10'0		X	X						
MK 10'10"		X	X						
*Additional Densities available upon request				info@markofoam.com			Rev. 11/06/17		

STRINGER OPTIONS

STRINGER OPTIONS

Stringerless (any size)

Standard Options (up to 10')

4mm Poplar Ply (stock up to 10')

6.5mm Poplar Ply

Basswood (up to 12')

1/8" Bass (stock 10' +)

3/16" Bass

1/4" Bass

3/8" Bass

1/2" Bass

3/4" Bass

1/4" Bass T-Band

3/8" Bass T-Band

1/2" Bass T-Band

Appelcore

1 Ply Black

2 Ply Brown

3 Ply Black

nat./brown/nat

brown/nat/brown

nat./black/nat

black/nat/black

HD Stringers (up to 8')

3lb PU up to 1" -(Red, Blue, Grey, Black)

6lb 3/4" L-Foam - Olive

BLANK CATALOG



WAKESURF REGULAR

PRESSURE MOLDED EPS BLANKS

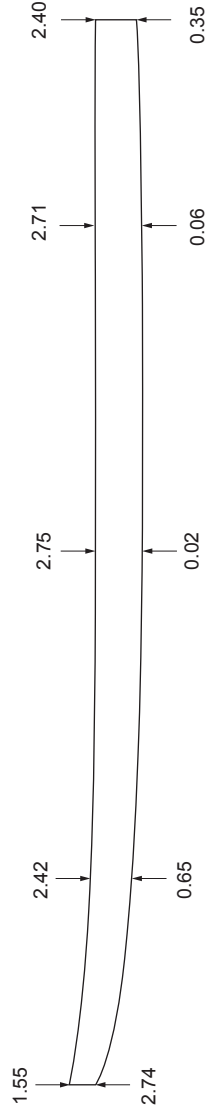
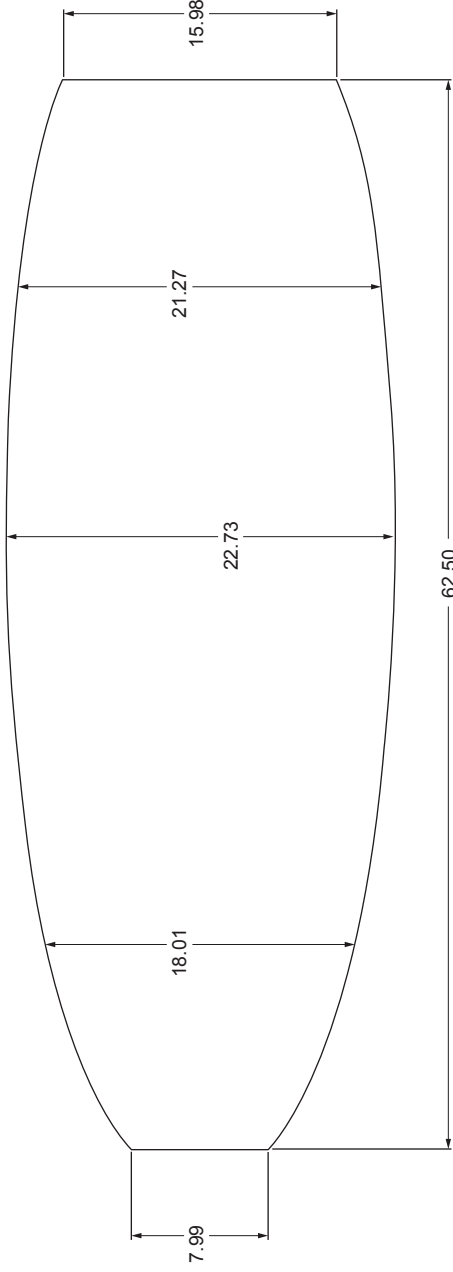

AVAILABLE DENSITIES:

*refer to density chart

STOCK STRINGER:

4mm poplar ply

BLANK DESCRIPTION

No waves, no problem! With help from customers and riders alike we have designed the perfect blank specifically made for the wakesurf world. From the Ocean to the Lake this Wakesurf blank has all you need to make yourself a killer custom wakesurf board.

THIS INFORMATION IN THIS DRAWING IS THE SOLE PROPERTY OF marko foam ANY REPRODUCTION IN PART OR AS A WHOLE WITHOUT THE WRITTEN PERMISSION OF marko foam IS PROHIBITED

100% RECYCLABLE

TITLE:

Wakesurf Regular

SHAPER:

Marko Foam

Updated 5-11-16



5'3" Foil

PRESSURE MOLDED EPS BLANKS

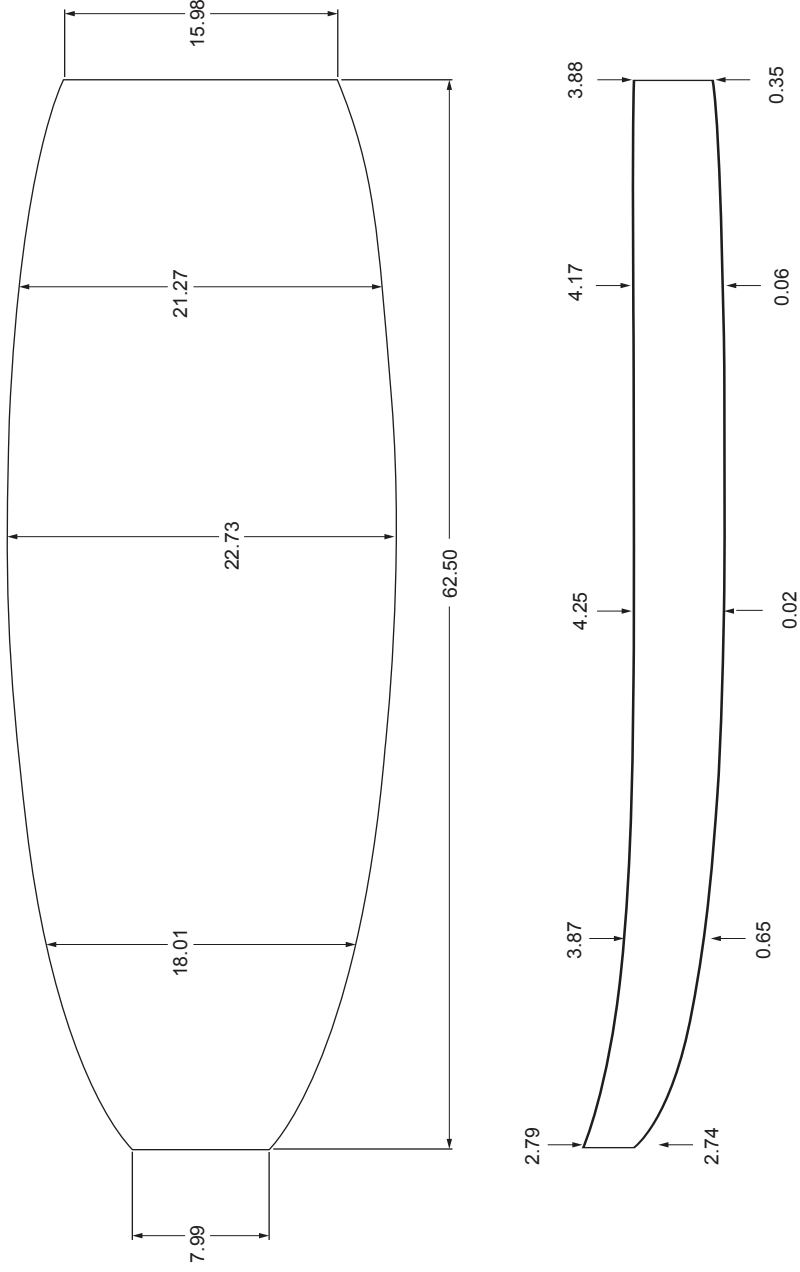

AVAILABLE DENSITIES:

*refer to density chart

STOCK STRINGER:

4mm poplar ply

BLANK DESCRIPTION

No waves, no problem! With help from customers and riders alike we have designed the perfect blank specifically made for the wakesurf world. From the Ocean to the Lake this Wakesurf blank has all you need to make yourself a killer custom wakesurf board.

THIS INFORMATION IN THIS DRAWING IS THE SOLE PROPERTY OF marko foam ANY REPRODUCTION IN PART OR AS A WHOLE WITHOUT THE WRITTEN PERMISSION OF marko foam IS PROHIBITED

100% RECYCLABLE

TITLE:

Wakesurf Regular

SHAPER:

Marko Foam



6'0" M-REGULAR

PRESSURE MOLDED EPS BLANKS

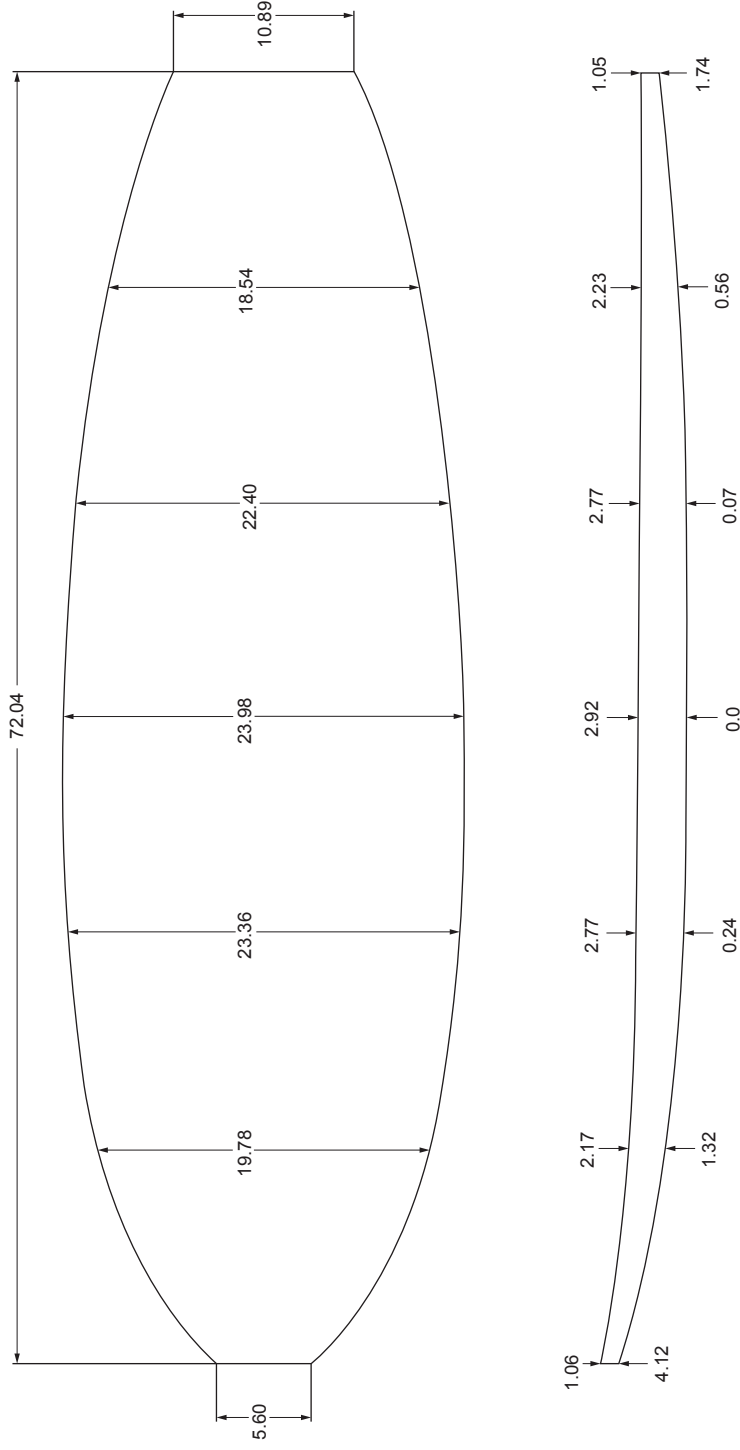

AVAILABLE DENSITIES:

*refer to density chart

STOCK STRINGER:

4mm poplar ply

BLANK DESCRIPTION

"From your cruiser fish to your groveling performance short board the 6'0" m regular can do it all. This new simplified molded blank, is perfect for almost all boards. The flat wide deck and bottom, square rails, and relaxed rocker caters to a wide variety of boards making its go to blank for the CNC Machine and Shapers alike. This blank is available stringerless or with our variety of stock stringers."

THIS INFORMATION IN THIS DRAWING IS THE SOLE PROPERTY OF marko foam ANY REPRODUCTION IN PART OR AS A WHOLE WITHOUT THE WRITTEN PERMISSION OF marko foam IS PROHIBITED

100% RECYCLABLE

TITLE:

6'0" M Regular

SHAPER:

Marko Foam

Updated 5-11-16



6'0" M-THICK

PRESSURE MOLDED EPS BLANKS

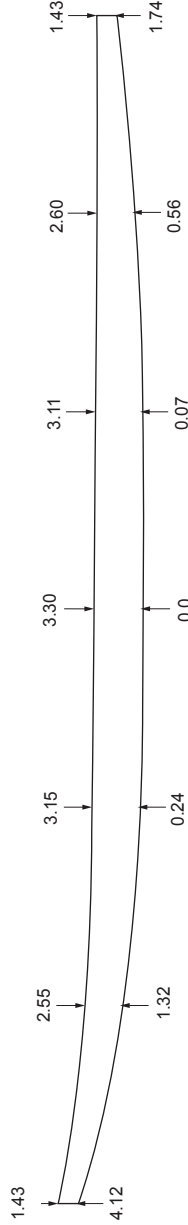
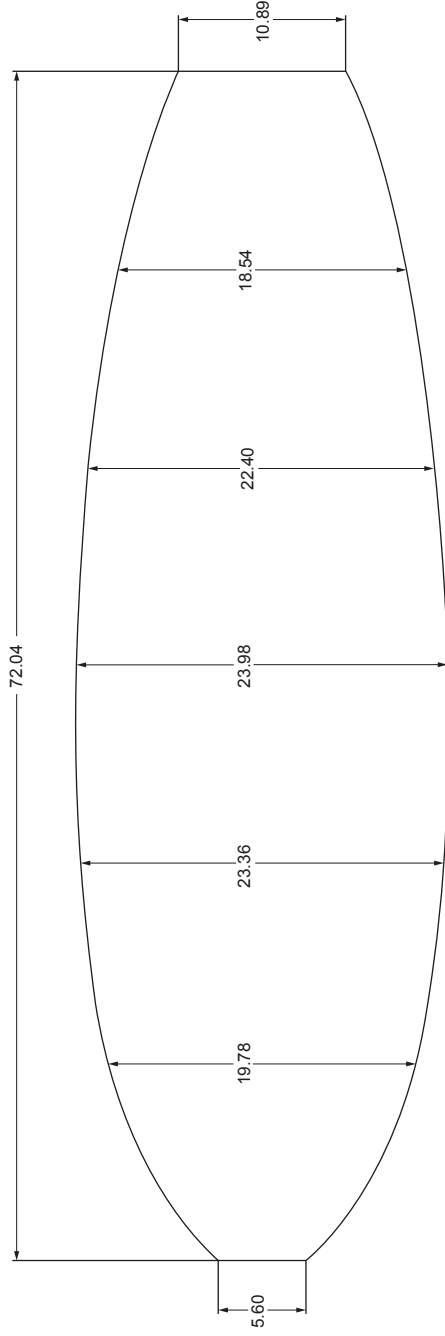

AVAILABLE DENSITIES:
*refer to density chart

STOCK STRINGER:
4mm poplar ply

Updated 5-11-16

BLANK DESCRIPTION
"From your cruiser fish to your groveling performance short board the 6'0" m thick can do it all. 's new simplified molded blank, is perfect for almost all boards. The wide deck and bottom, square rails, and relaxed rocker caters to a wide variety of boards making it a go to blank for the CNC Machine and Shapers alike. 's blanks available stringerless or with our variety of stock stringers."

THIS INFORMATION IN THIS DRAWING IS THE SOLE PROPERTY OF marko foam ANY REPRODUCTION IN PART OR AS A WHOLE WITHOUT THE WRITTEN PERMISSION OF marko foam IS PROHIBITED

100% RECYCLABLE	
TITLE:	SHAPER:
6'0" M Thick	Marko Foam



6'1" PESCADO

PRESSURE MOLDED EPS BLANKS

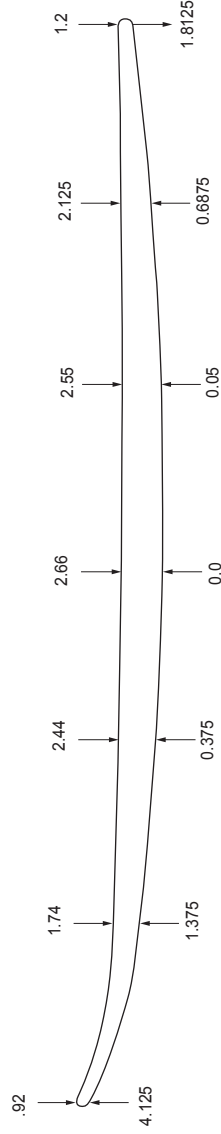
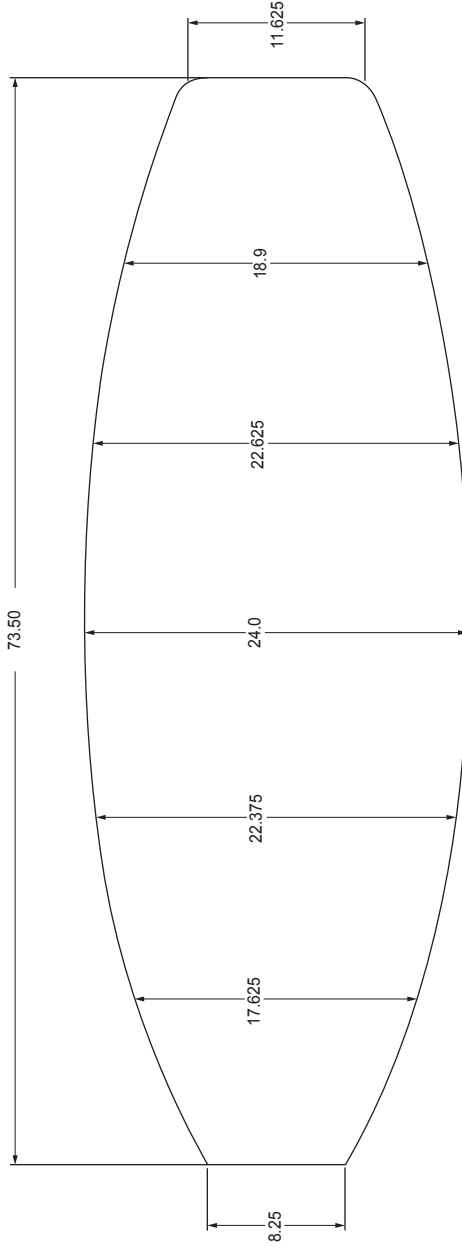

AVAILABLE DENSITIES:
*refer to density chart
STOCK STRINGER:
4mm poplar ply
Not Available in a Stringerless Blank

BLANK DESCRIPTION
Hybrid fish style blank with plenty of width throughout.
Good for hand shaping or tight tolerance machining.

THIS INFORMATION IN THIS DRAWING IS THE SOLE PROPERTY OF marko foam ANY REPRODUCTION IN PART OR AS A WHOLE WITHOUT THE WRITTEN PERMISSION OF marko foam IS PROHIBITED

100% RECYCLABLE

TITLE:
6'1" PESCADO

SHAPER:
Marko Foam

Updated 5-11-16



6'2" H-NEW

PRESSURE MOLDED EPS BLANKS

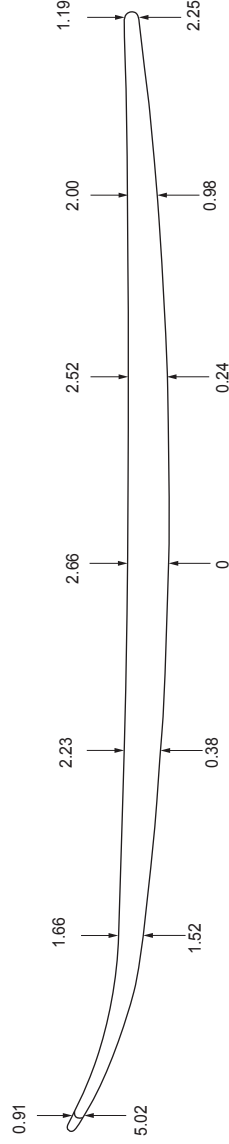
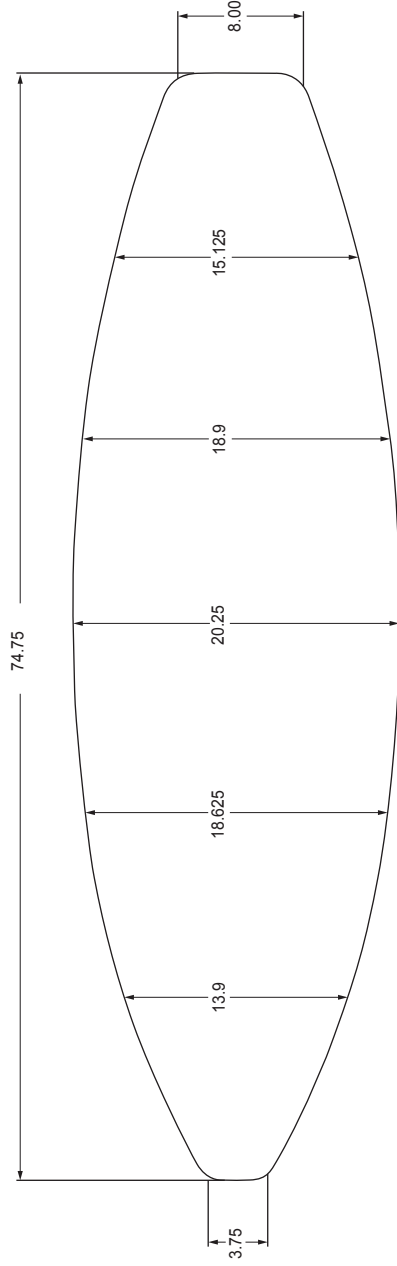

AVAILABLE DENSITIES:
*refer to density chart
STOCK STRINGER:
4mm poplar ply

BLANK DESCRIPTION
Standard short board blank made for hand shaping or tight tolerance machining.

THIS INFORMATION IN THIS DRAWING IS THE SOLE PROPERTY OF marko foam
ANY REPRODUCTION IN PART OR AS A WHOLE WITHOUT THE WRITTEN PERMISSION OF marko foam IS PROHIBITED

100% RECYCLABLE

TITLE: 6'2" H-NEW
SHAPER: Marko Foam

Updated 5-11-16



6'2" THICK

PRESSURE MOLDED EPS BLANKS

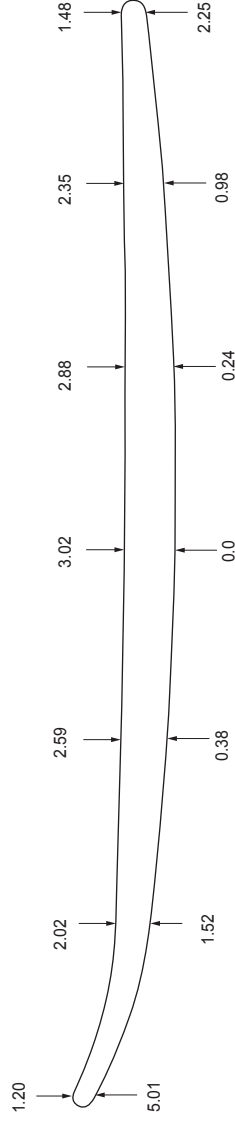
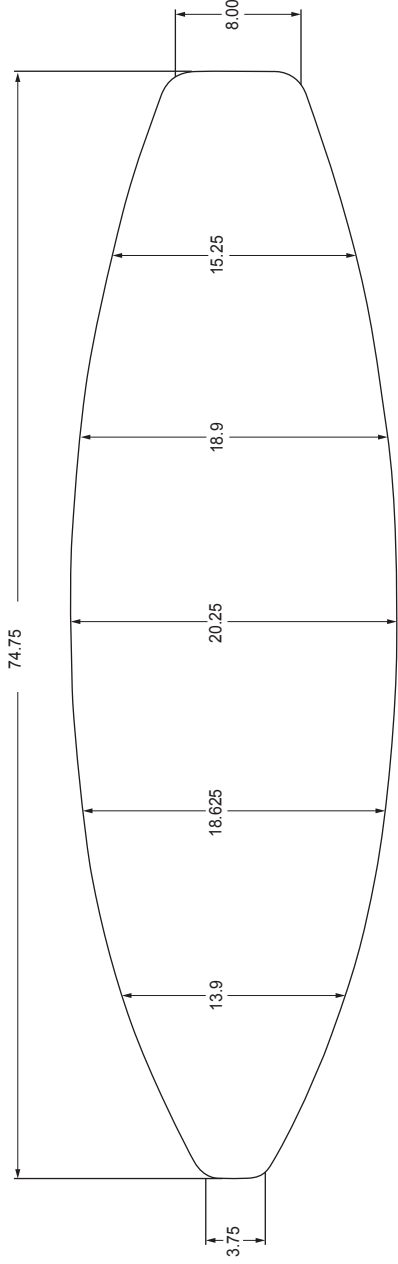

AVAILABLE DENSITIES:
*refer to density chart
STOCK STRINGER:
4mm poplar ply

BLANK DESCRIPTION
This blank is designed for machine shaping and has extra material in the nose area for thicker models.

THIS INFORMATION IN THIS DRAWING IS THE SOLE PROPERTY OF marko foam ANY REPRODUCTION IN PART OR AS A WHOLE WITHOUT THE WRITTEN PERMISSION OF marko foam IS PROHIBITED

100% RECYCLABLE

TITLE: SHAPER:

6'2" THICK Marko Foam

Updated 5-11-16



6'4" TP

PRESSURE MOLDED EPS BLANKS

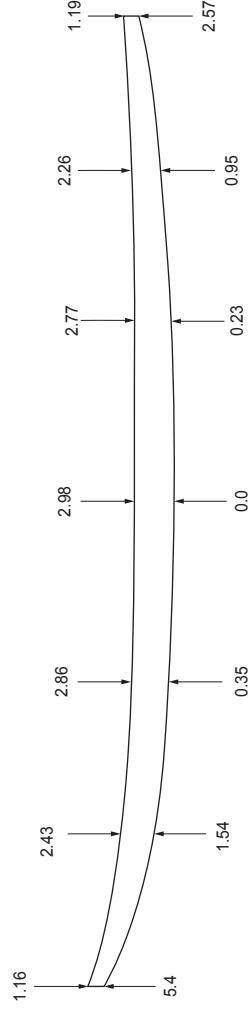
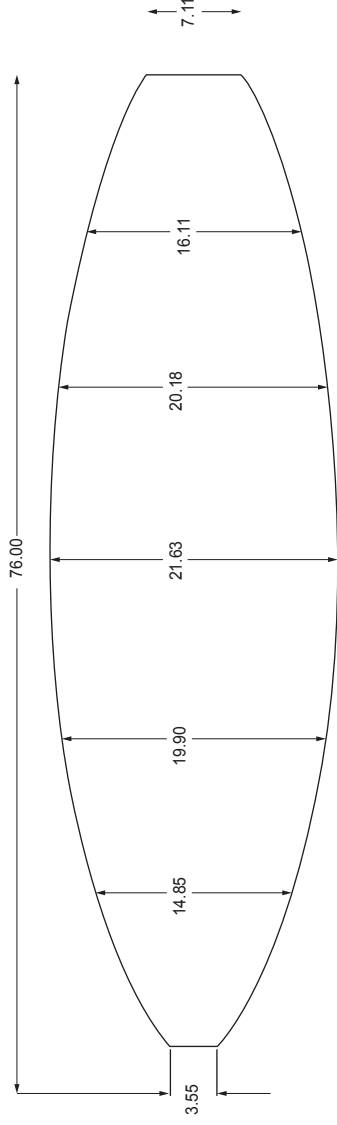

AVAILABLE DENSITIES:
*refer to density chart
STOCK STRINGER:
4mm poplar ply

BLANK DESCRIPTION

This blank is made for hand or machine shaping. Great all purpose "go to" blank.

THIS INFORMATION IN THIS DRAWING IS THE SOLE PROPERTY OF marko foam ANY REPRODUCTION IN PART OR AS A WHOLE WITHOUT THE WRITTEN PERMISSION OF marko foam IS PROHIBITED

100% RECYCLABLE

TITLE:

SHAPER:

6'4" TP

T.PATTERSON

Updated 5-11-16



6'4" THICK

PRESSURE MOLDED EPS BLANKS

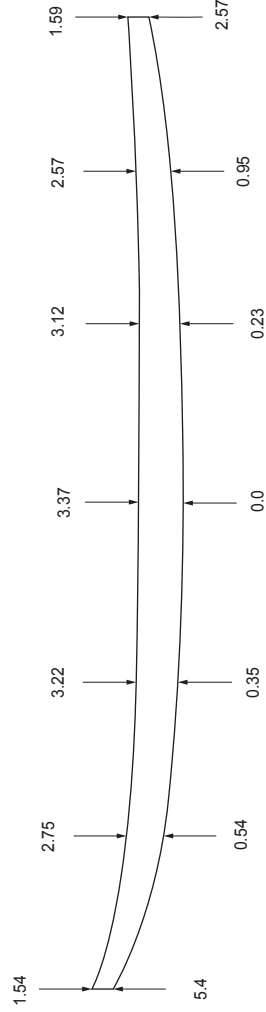
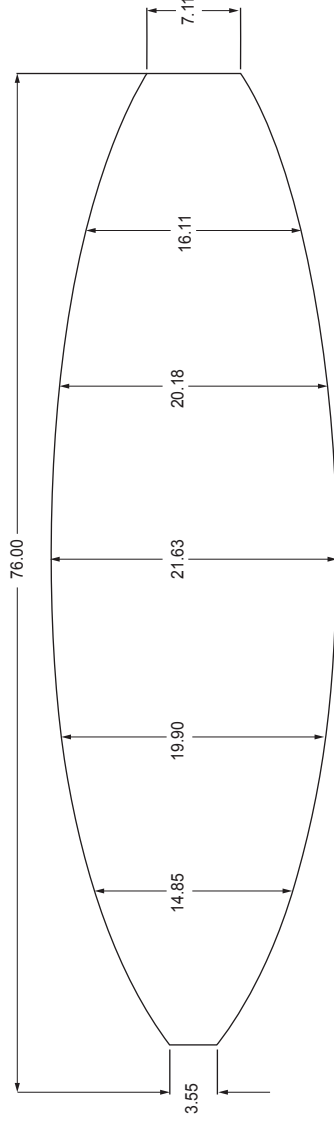

AVAILABLE DENSITIES:
*refer to density chart
STOCK STRINGER:
4mm poplar ply

BLANK DESCRIPTION
This blank is made for hand or machine shaping. Great all purpose "go to" blank.

THIS INFORMATION IN THIS DRAWING IS THE SOLE PROPERTY OF marko foam
ANY REPRODUCTION IN PART OR AS A WHOLE WITHOUT THE WRITTEN PERMISSION OF marko foam IS PROHIBITED

100% RECYCLABLE

TITLE: SHAPER:

6'4" TP THICK T.PATTERSON

Updated 5-11-16



6'6" M

PRESSURE MOLDED EPS BLANKS

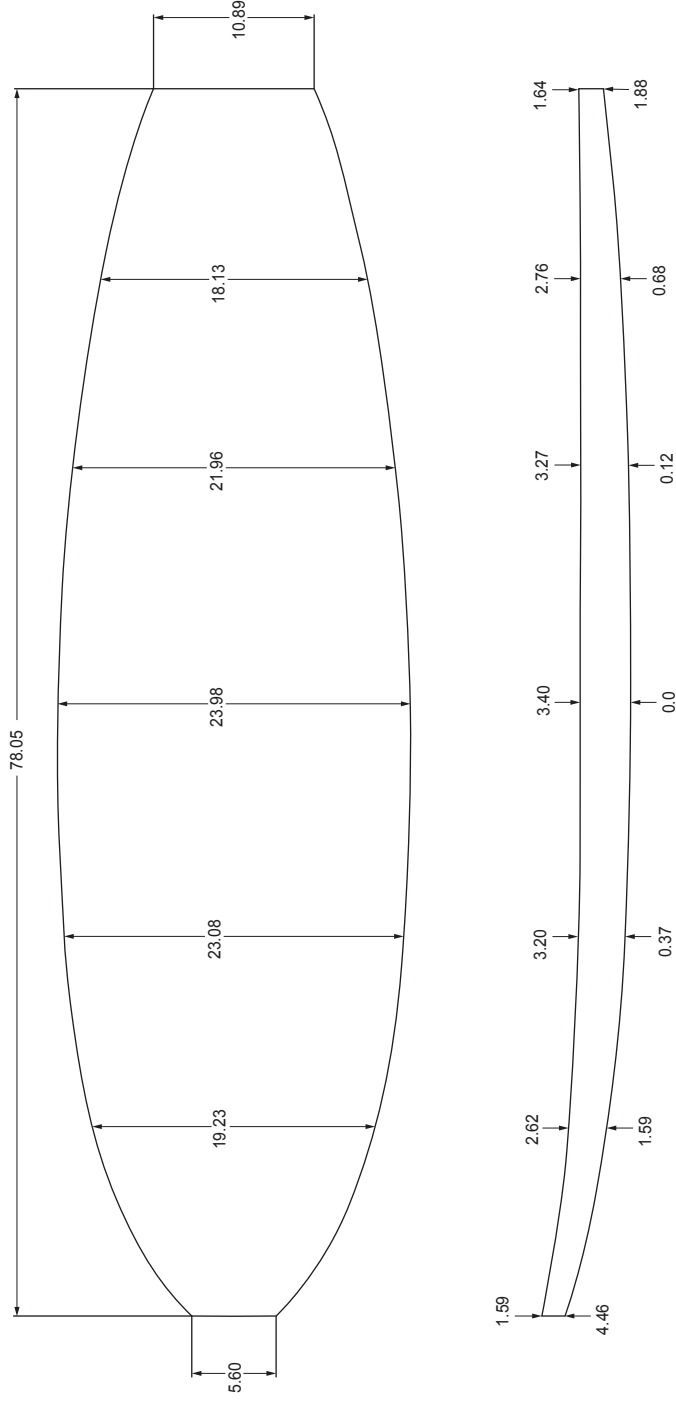

AVAILABLE DENSITIES:
*refer to density chart

STOCK STRINGER:
4mm poplar ply

Updated 5-11-16

BLANK DESCRIPTION
"From your cruiser fish to your groveling performance short board the 6'6" m can do it all. This new simplified molded blank, is perfect for almost all boards. The flat wide deck and bottom, square rails, and relaxed rocker caters to a wide variety of boards making it a go to blank for the CNC Machine and Shapers alike. This blank is available stringerless or with our variety of stock stringers."

THIS INFORMATION IN THIS DRAWING IS THE SOLE PROPERTY OF marko foam
ANY REPRODUCTION IN PART OR AS A WHOLE WITHOUT THE WRITTEN PERMISSION OF marko foam IS PROHIBITED

100% RECYCLABLE

TITLE: SHAPER:
6'6" M Marko Foam



6'9" REGULAR

PRESSURE MOLDED EPS BLANKS

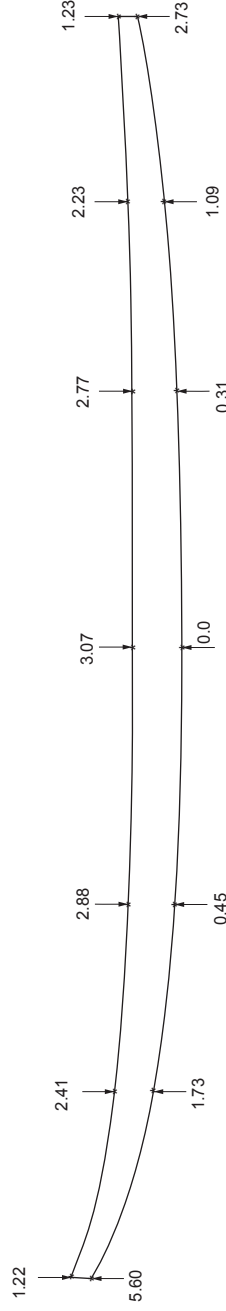
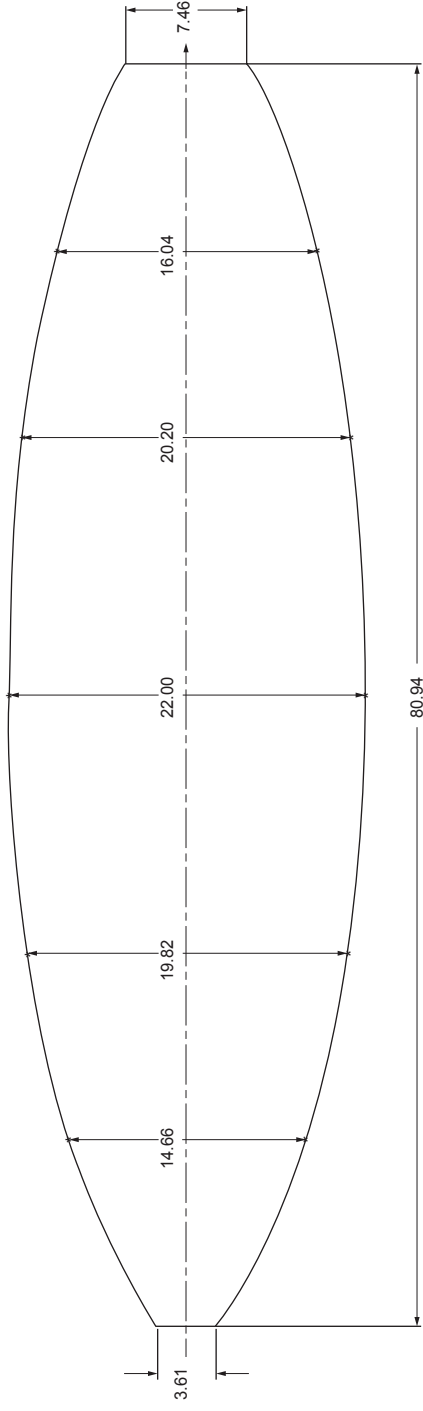

STRINGER OPTIONS:
REFER TO STRINGER LIST

DENSITY OPTIONS:
REFER TO DENSITY CHART

BLANK DESCRIPTION

If you're looking to make a step-up for larger surf or a bigger high performance surfboard, this blank has what you need. With its high-performance rocker and a wide variety of available thicknesses, it's a perfect blank for both hand and machine shaping. The square rails and flat deck give you all the control in what masterpiece this blank will yield.

THIS INFORMATION IN THIS DRAWING IS THE SOLE PROPERTY OF MARKO FOAM ANY REPRODUCTION IN PART OR AS A WHOLE WITHOUT THE WRITTEN PERMISSION OF MARKO FOAM IS PROHIBITED

100% RECYCLABLE

TITLE:	6'9" REG
SHAPER:	MARKO FOAM



6'9" THICK

PRESSURE MOLDED EPS BLANKS

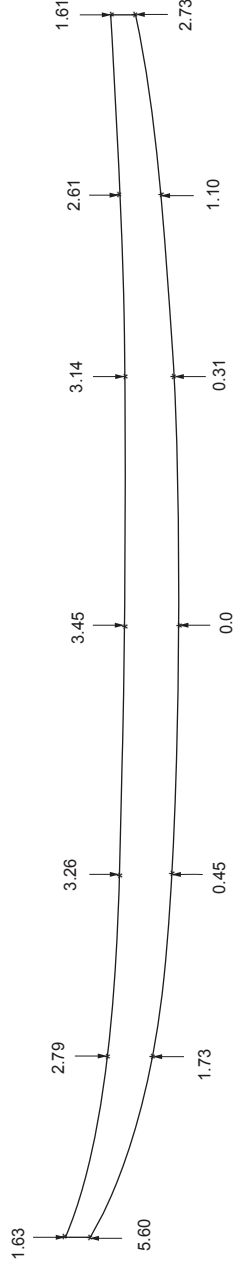
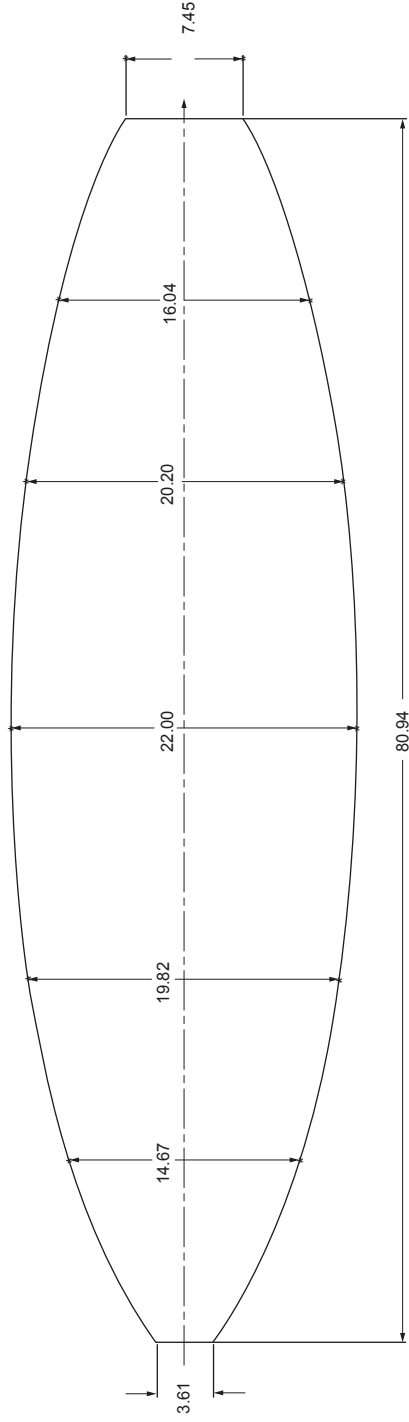

STRINGER OPTIONS:
REFER TO STRINGER LIST

DENSITY OPTIONS:
REFER TO DENSITY CHART

BLANK DESCRIPTION

If you're looking to make a step-up for larger surf or a bigger high performance surfboard, this blank has what you need. With its high-performance rocker and a wide variety of available thicknesses, it's a perfect blank for both hand and machine shaping. The square rails and flat deck give you all the control in what masterpiece this blank will yield.

THIS INFORMATION IN THIS DRAWING IS THE SOLE PROPERTY OF MARKO FOAM
ANY REPRODUCTION IN PART OR AS A WHOLE WITHOUT THE WRITTEN PERMISSION OF MARKO FOAM IS PROHIBITED

100% RECYCLABLE

TITLE:

SHAPER:

6'9" THICK

MARKO FOAM



7'2" M REGULAR

PRESSURE MOLDED EPS BLANKS

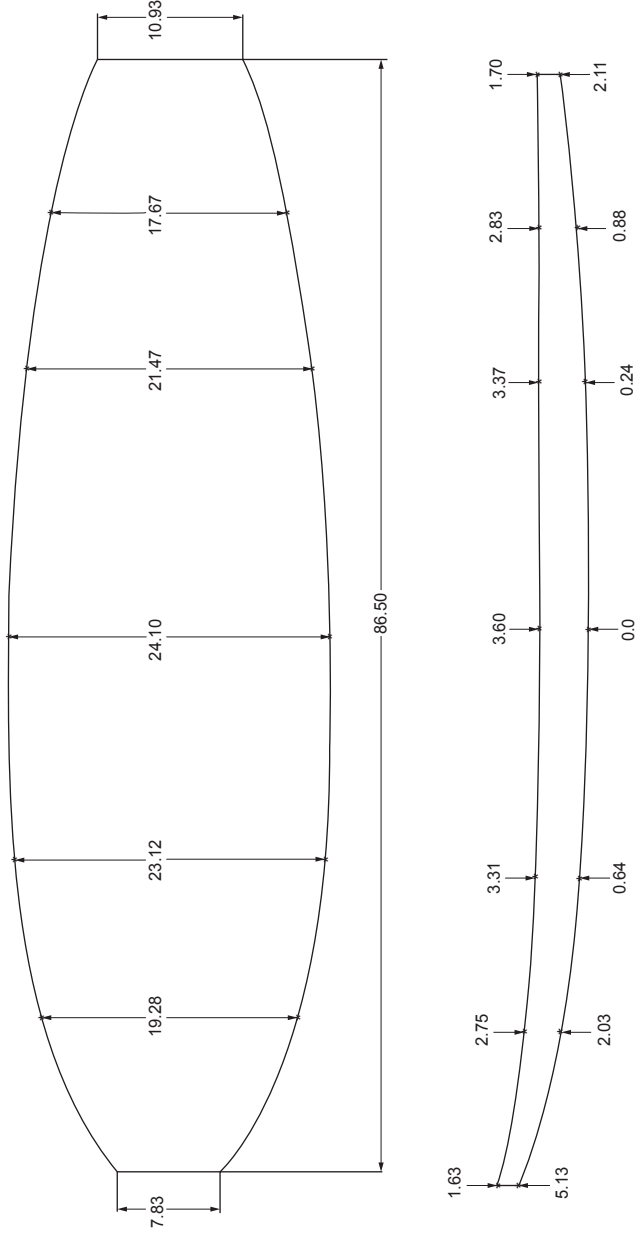

<p>AVAILABLE DENSITIES: *refer to density chart</p> <p>STOCK STRINGER: 4mm poplar ply</p> <p style="text-align: right;">Updated 5-11-16</p>	<p>BLANK DESCRIPTION</p> <p>The 7'2" M Regular can do it all. The new simplified molded blank is perfect for almost all boards. The wide deck and bottom, square rails and relaxed rocker caters to a wide variety of boards making it a go to blank for CNC machines and hand shapers alike. This blank is available stringer-less.</p>	<p>THIS INFORMATION IN THIS DRAWING IS THE SOLE PROPERTY OF MARKO FOAM</p> <p>ANY REPRODUCTION IN PART OR AS A WHOLE WITHOUT THE WRITTEN PERMISSION OF MARKO FOAM IS PROHIBITED</p>	<p style="text-align: center;">100% RECYCLABLE</p> <table border="1"> <tr> <td data-bbox="1277 193 1324 569">TITLE:</td> <td data-bbox="1324 193 1403 569">7'2" M Regular</td> </tr> <tr> <td data-bbox="1277 569 1324 801">SHAPER:</td> <td data-bbox="1324 569 1403 801">Marko Foam</td> </tr> </table>	TITLE:	7'2" M Regular	SHAPER:	Marko Foam
TITLE:	7'2" M Regular						
SHAPER:	Marko Foam						



7'2" M THICK

PRESSURE MOLDED EPS BLANKS

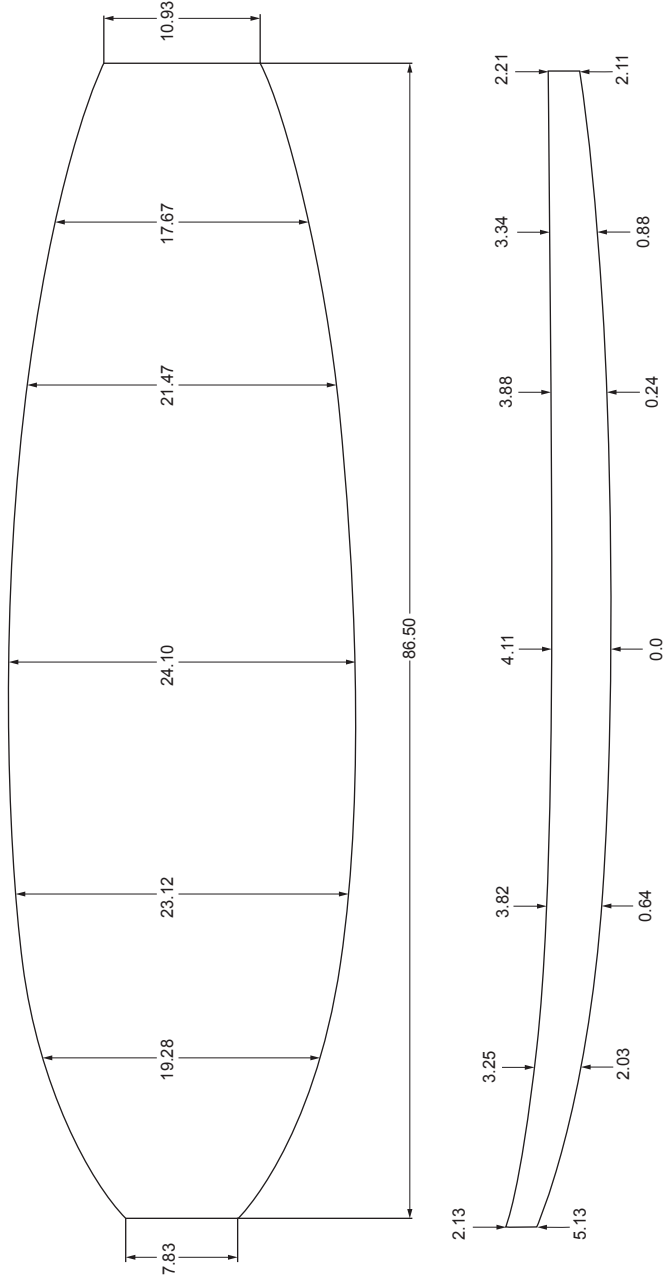

AVAILABLE DENSITIES: *refer to density chart STOCK STRINGER: 4mm poplar ply	BLANK DESCRIPTION The 7'2" M Thick can do it all. The new simplified molded blank is perfect for almost all boards. The wide deck and bottom, square rails and relaxed rocker caters to a wide variety of boards making it a go to blank for CNC machines and hand shapers alike. This blank is available stringer-less.	THIS INFORMATION IN THIS DRAWING IS THE SOLE PROPERTY OF MARKO FOAM ANY REPRODUCTION IN PART OR AS A WHOLE WITHOUT THE WRITTEN PERMISSION OF MARKO FOAM IS PROHIBITED	100% RECYCLABLE	
			TITLE: 7'2" M Thick	SHAPER: Marko Foam
Updated 5-11-16				



7'4" HALIBUT

PRESSURE MOLDED EPS BLANKS

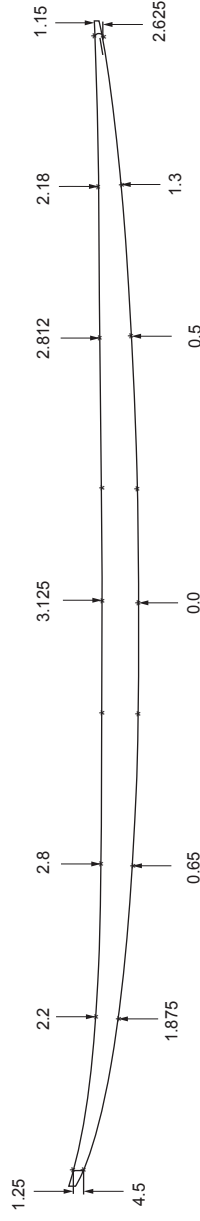
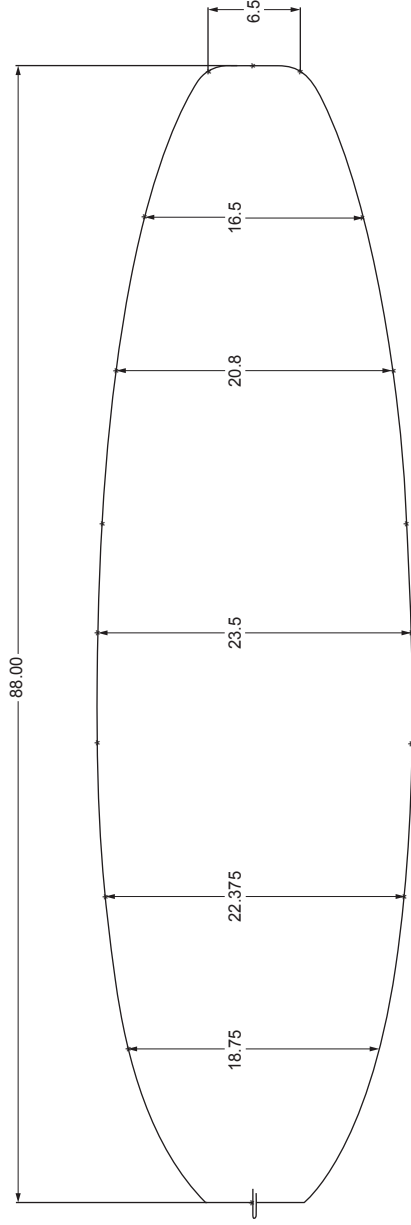

<p>A AVAILABLE DENSITIES: *refer to density chart</p> <p>STOCK STRINGER: 4mm poplar ply Not Available in a Stringerless Blank</p> <p style="text-align: right;">Updated 5-11-16</p>	<p>BLANK DESCRIPTION</p> <p>Big guy fish blank with plenty of deckroll for hand shaping or machine cuts. This blank should be able to fit most any mid size fish or big guy models.</p>	<p>THIS INFORMATION IN THIS DRAWING IS THE SOLE PROPERTY OF MARKO FOAM</p> <p>ANY REPRODUCTION IN PART OR AS A WHOLE WITHOUT THE WRITTEN PERMISSION OF MARKO FOAM IS PROHIBITED</p>	<p style="text-align: center;">100% RECYCLABLE</p> <table border="1" style="width: 100%;"> <tr> <td style="width: 50%;">TITLE:</td> <td style="width: 50%;">7'4" HALIBUT</td> </tr> <tr> <td>SHAPER:</td> <td>Marko Foam</td> </tr> </table>	TITLE:	7'4" HALIBUT	SHAPER:	Marko Foam
TITLE:	7'4" HALIBUT						
SHAPER:	Marko Foam						



7'5" MACHINE ALL

PRESSURE MOLDED EPS BLANKS

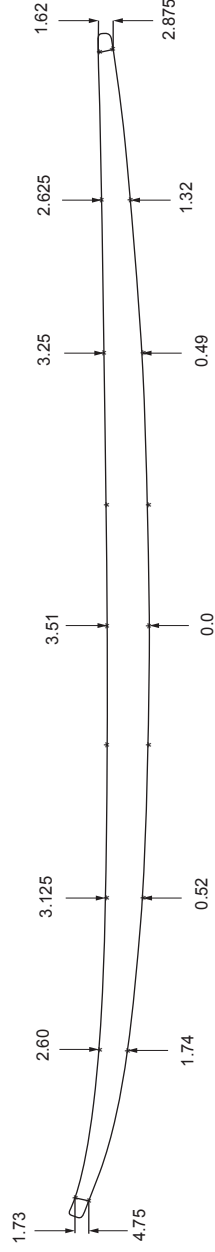
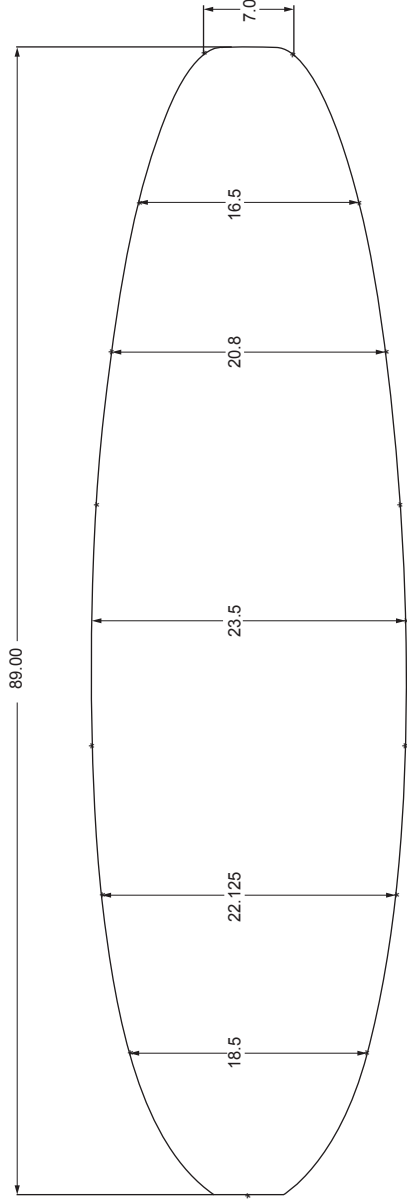

<p>AVAILABLE DENSITIES: *refer to density chart</p> <p>STOCK STRINGER: 4mm poplar ply Not Available in a Stringerless Blank</p> <p style="text-align: right;">Updated 5-11-16</p>	<p>BLANK DESCRIPTION</p> <p>This blank is designed for machine shaping and capturing the Big Guy hybrid shapes. The natural rocker achieves most all needs, and can be altered to your specs.</p>	<p>THIS INFORMATION IS THE SOLE PROPERTY OF MARKO FOAM</p> <p>ANY REPRODUCTION IN PART OR AS A WHOLE WITHOUT THE WRITTEN PERMISSION OF MARKO FOAM IS PROHIBITED</p>	<p style="text-align: center; font-size: 2em; font-weight: bold;">100% RECYCLABLE</p> <p>TITLE: 7'5" MACHINE ALL</p> <p>SHAPER: Marko Foam</p>
---	--	---	--

7'6" THICK

PRESSURE MOLDED EPS BLANKS

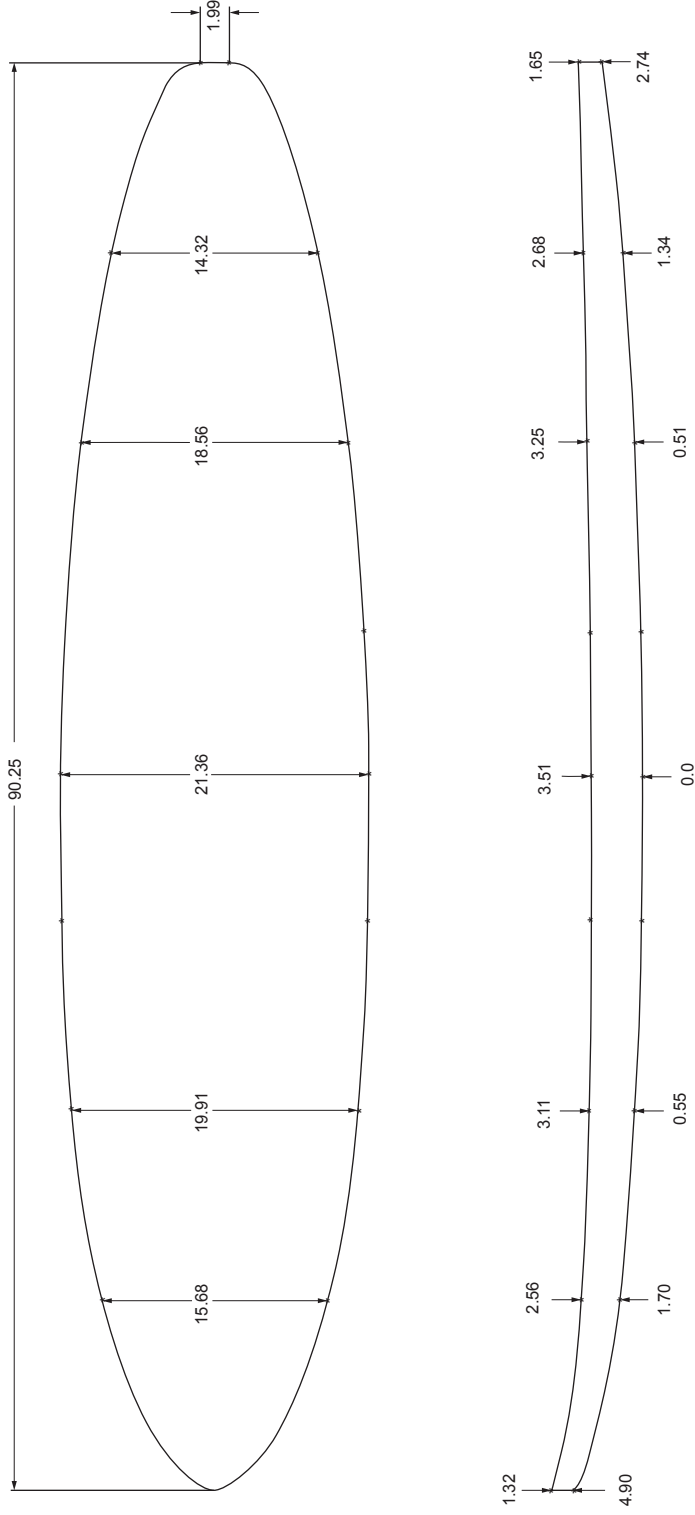

AVAILABLE DENSITIES:
*refer to density chart
STOCK STRINGER:
4mm poplar ply

BLANK DESCRIPTION

This blank is very similar to the 7'6" JJ with the fun board rocker making it perfect your bigger shortboards and big hybrid shapes. It has added thickness making it perfect machine shaping and giving you a volume to work with.

Updated 5-11-16

THIS INFORMATION IN THIS DRAWING IS THE SOLE PROPERTY OF MARKO FOAM ANY REPRODUCTION IN PART OR AS A WHOLE WITHOUT THE WRITTEN PERMISSION OF MARKO FOAM IS PROHIBITED

100% RECYCLABLE

TITLE: SHAPER:

7'6" Thick

JEFF JOHNSTON



7'6" JJ

PRESSURE MOLDED EPS BLANKS

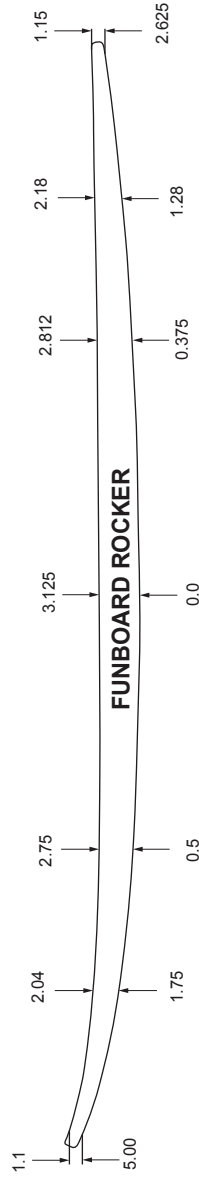
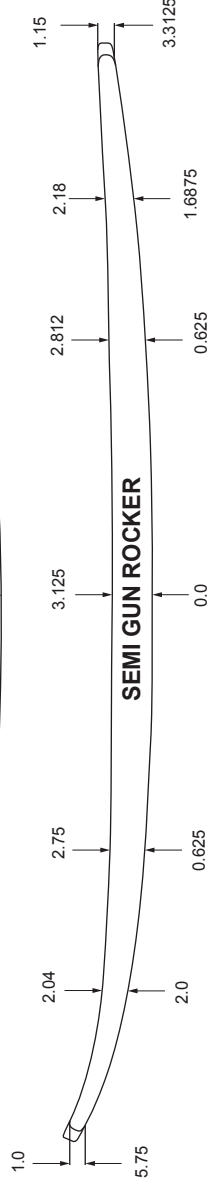
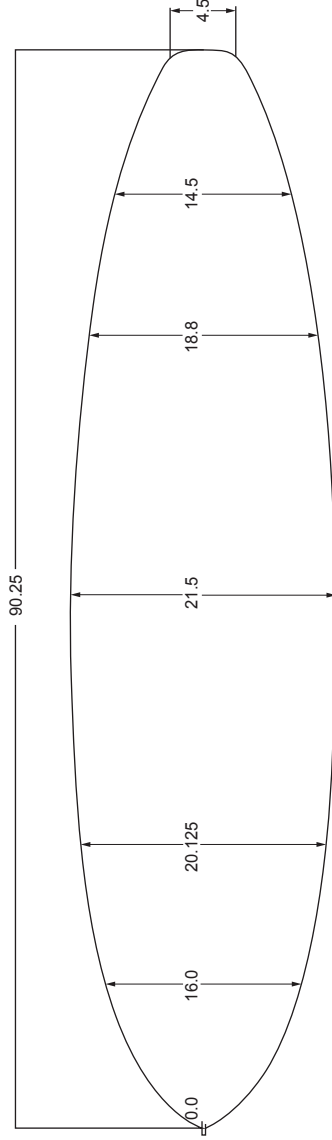

A AVAILABLE DENSITIES:
*refer to density chart
STOCK STRINGER:
4mm poplar ply

BLANK DESCRIPTION
This ideal blank for larger short boards, mini guns and big hybrid shapes that need more rocker. Good for hand shaping and plenty of thickness throughout for machine cuts. Available in fun board and Semigun rocker.

THIS INFORMATION IN THIS DRAWING IS THE SOLE PROPERTY OF MARKO FOAM ANY REPRODUCTION IN PART OR AS A WHOLE WITHOUT THE WRITTEN PERMISSION OF MARKO FOAM IS PROHIBITED

100% RECYCLABLE

TITLE:	7'6" JJ
SHAPER:	JEFF JOHNSTON



8'5" UNIVERSAL

PRESSURE MOLDED EPS BLANKS

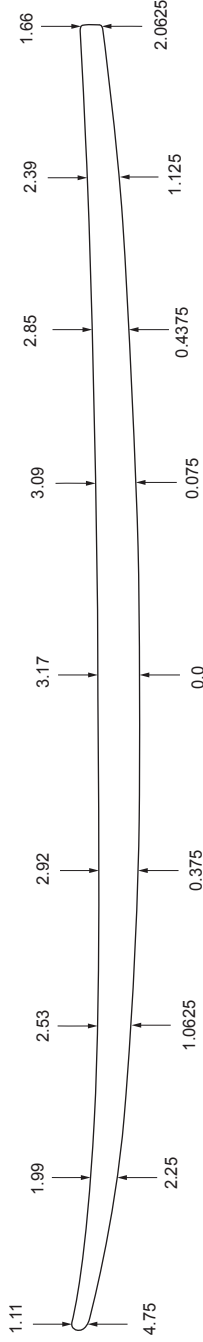
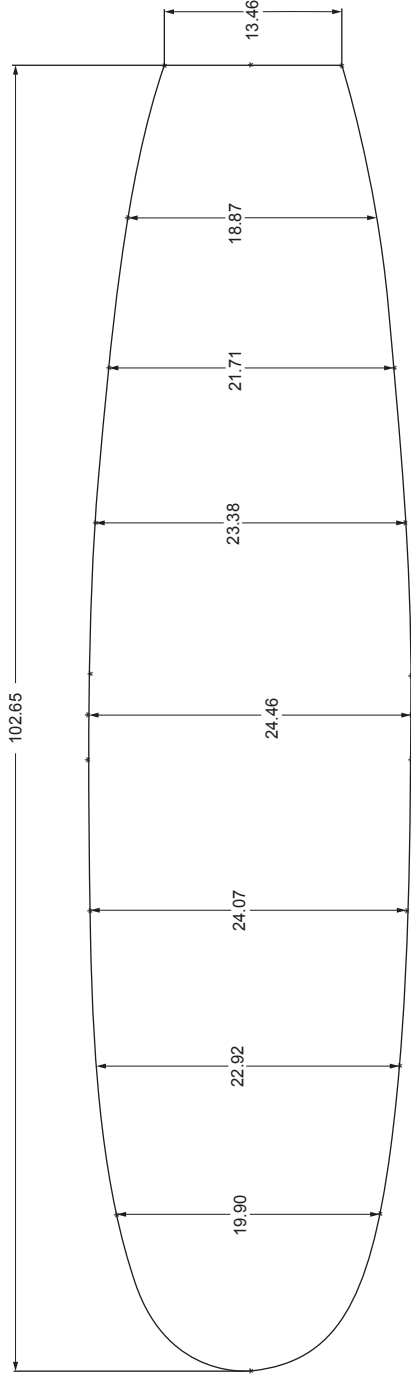

AVAILABLE DENSITIES: *refer to density chart STOCK STRINGER: 4mm poplar ply	BLANK DESCRIPTION A very well balanced blank for hand shaping with room to move for cutting on the machine. Blank is shaped with a slight concave to maximize board design and thickness.	THIS INFORMATION IN THIS DRAWING IS THE SOLE PROPERTY OF MARKO FOAM ANY REPRODUCTION IN PART OR AS A WHOLE WITHOUT THE WRITTEN PERMISSION OF MARKO FOAM IS PROHIBITED	100% RECYCLABLE
Updated 5-11-16			TITLE: 8'5" UNIVERSAL
			SHAPER: Marko Foam

8'5" THICK

PRESSURE MOLDED EPS BLANKS

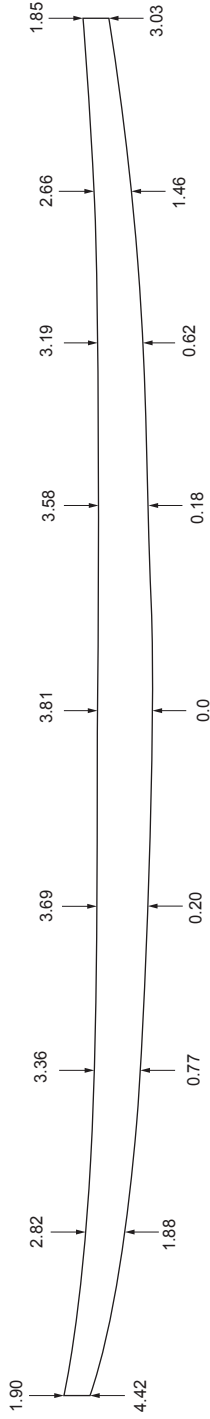
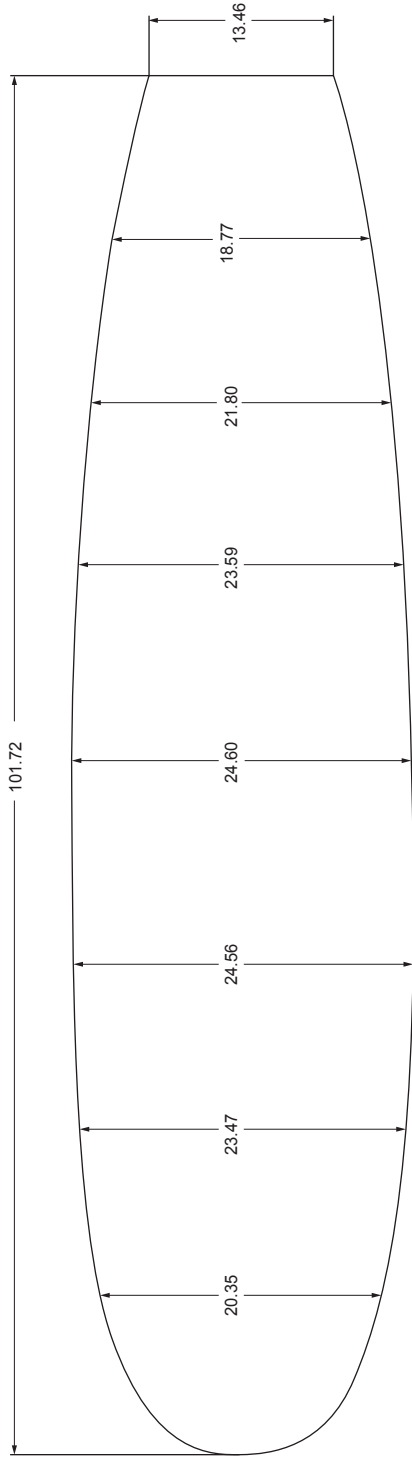

<p>AVAILABLE DENSITIES: *refer to density chart</p> <p>STOCK STRINGER: 4mm poplar ply</p>	<p>BLANK DESCRIPTION</p> <p>From a big fish to a longboard and everything in between, this blank can do it all. With added thickness from the 8'5" universal this blank can fit almost any board and is perfect for machine shaping.</p>	<p>THIS INFORMATION IS THE SOLE PROPERTY OF MARKO FOAM</p> <p>ANY REPRODUCTION IN PART OR AS A WHOLE WITHOUT THE WRITTEN PERMISSION OF MARKO FOAM IS PROHIBITED</p>	<p>100% RECYCLABLE</p>
<p>Updated 5-11-16</p>			<p>TITLE: 8'5" Thick</p> <p>SHAPER: Marko Foam</p>



9'1" JJ HYPER - FORM

PRESSURE MOLDED EPS BLANKS

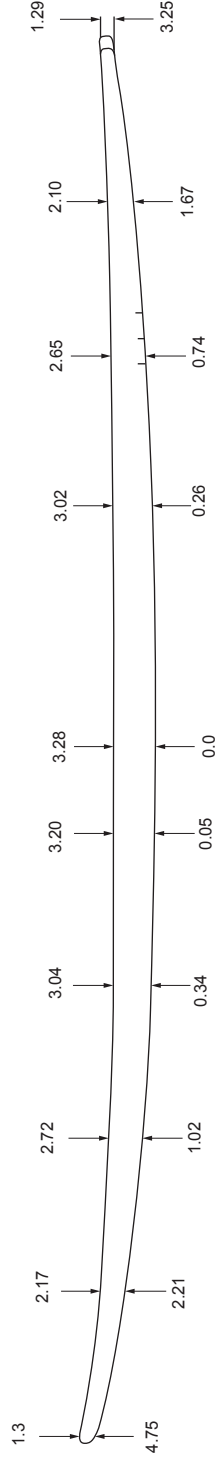
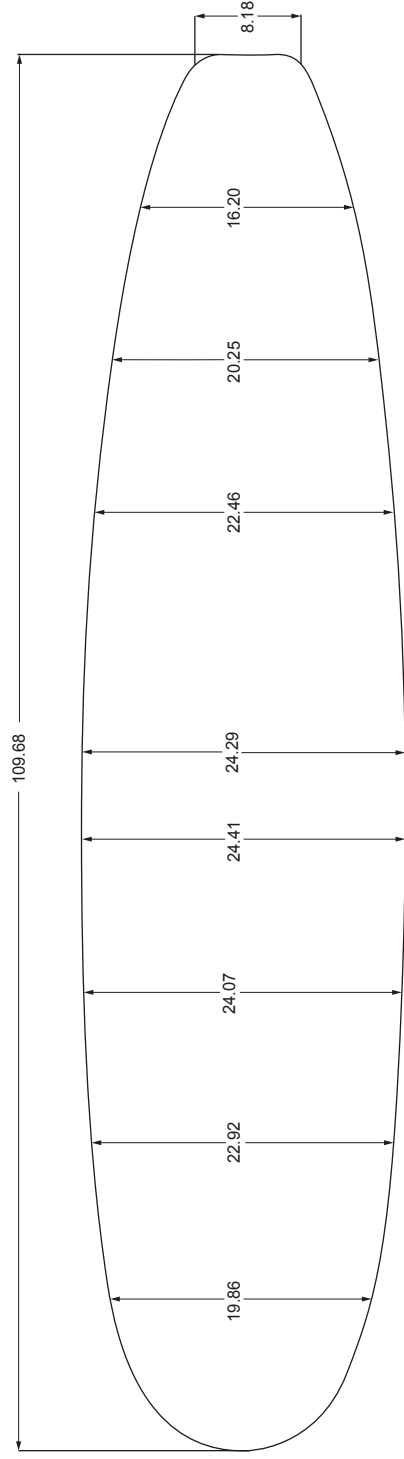

<p>AVAILABLE DENSITIES: *refer to density chart</p> <p>STOCK STRINGER: 4mm poplar ply</p> <p style="text-align: right;">Updated 5-11-16</p>	<p>BLANK DESCRIPTION</p> <p>A very well balanced blank for hand shaping with room to move for cutting on the machine. Blank is shaped with a slight concave to maximize board design and thickness.</p>	<p>THIS INFORMATION IN THIS DRAWING IS THE SOLE PROPERTY OF MARKO FOAM</p> <p>ANY REPRODUCTION IN PART OR AS A WHOLE WITHOUT THE WRITTEN PERMISSION OF MARKO FOAM IS PROHIBITED</p>	<p style="text-align: center; font-size: 2em; font-weight: bold;">100% RECYCLABLE</p> <p>TITLE: 9'1" JJ HYPER - FORM</p> <p>SHAPER: JEFF JOHNSTON</p>
---	--	---	---



9'1" MACHINE ALL

PRESSURE MOLDED EPS BLANKS

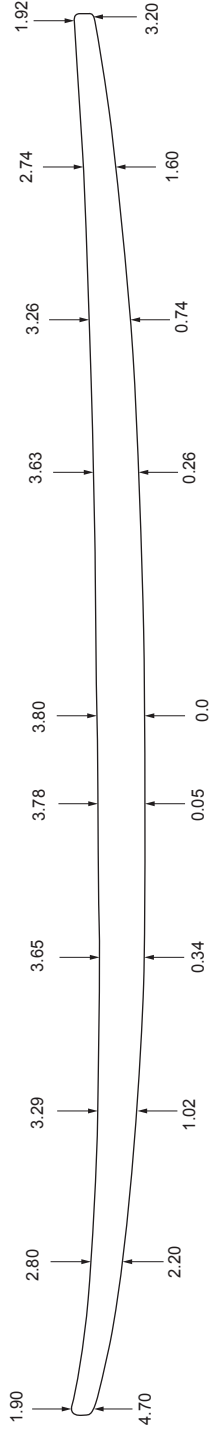
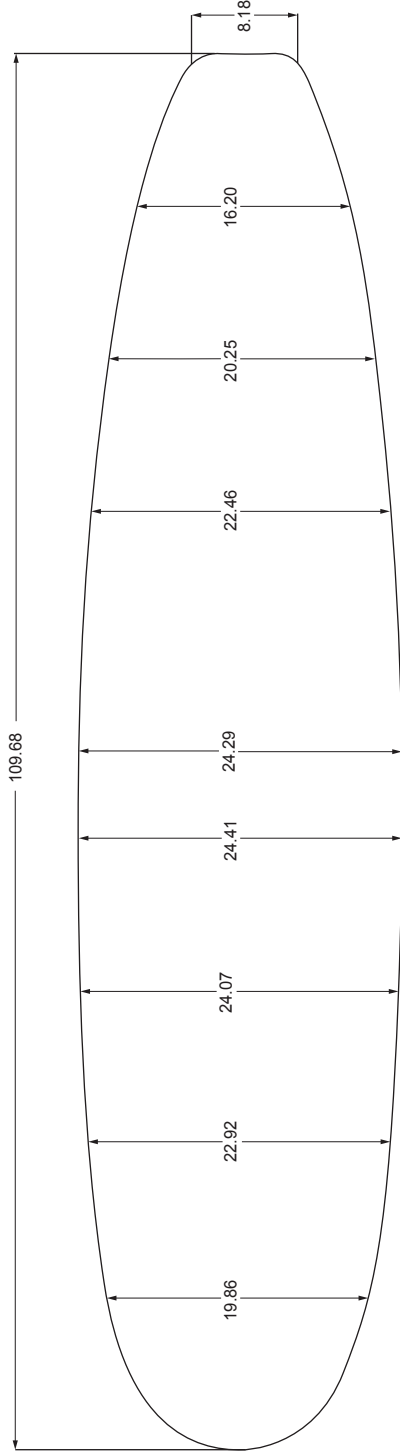

AVAILABLE DENSITIES: *refer to density chart STOCK STRINGER: 4mm poplar ply Updated 5-11-16	BLANK DESCRIPTION This blank is designed for machine shaping and capturing most all big guy hybrid and performance long boards. Natural rocker can be altered to meet your needs.	THIS INFORMATION IN THIS DRAWING IS THE SOLE PROPERTY OF MARKO FOAM ANY REPRODUCTION IN PART OR AS A WHOLE WITHOUT THE WRITTEN PERMISSION OF MARKO FOAM IS PROHIBITED	100% RECYCLABLE TITLE: 9'1" MACHINE ALL SHAPER: Marko Foam
---	---	--	---



9'6" MK

BLOCK CUT EPS

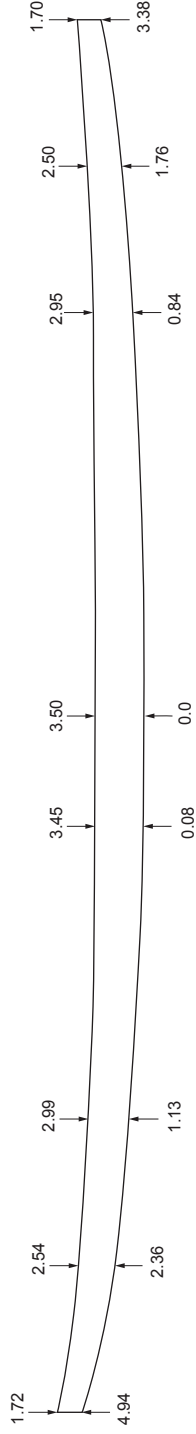
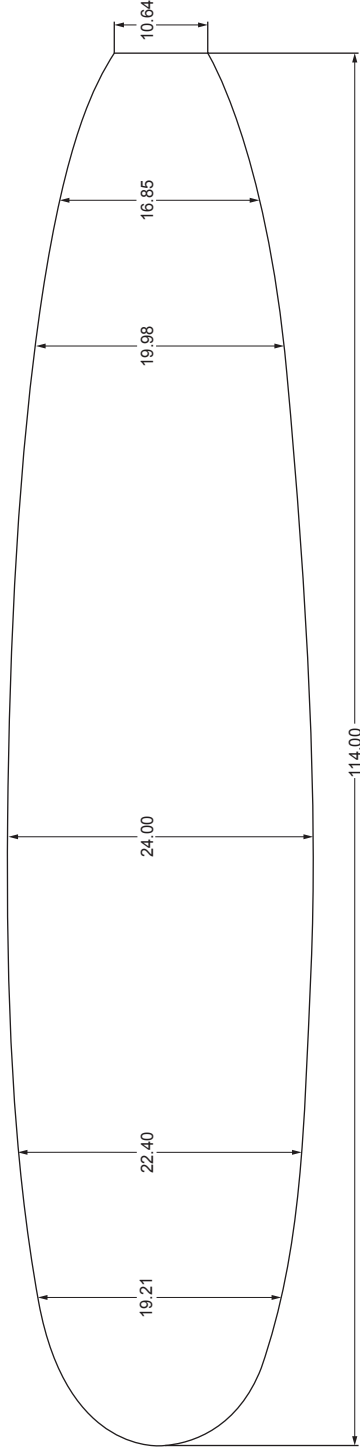

AVAILABLE DENSITIES:

*refer to density chart

STOCK STRINGER:

4mm poplar ply

BLANK DESCRIPTION

A blank made perfectly for your next longboard. With plenty of width and thickness it is perfect for a mellow cruiser or a high performance log. This blank is cut out of block EPS on a computer controlled hotwire machine to ensure the same blank dimensions everytime.

Updated 5-11-16

THIS INFORMATION IN THIS DRAWING IS THE SOLE PROPERTY OF MARKO FOAM ANY REPRODUCTION IN PART OR AS A WHOLE WITHOUT THE WRITTEN PERMISSION OF MARKO FOAM IS PROHIBITED

100% RECYCLABLE

TITLE:

9'6" MK

SHAPER:

Marko Foam



10'0" MK

BLOCK CUT EPS

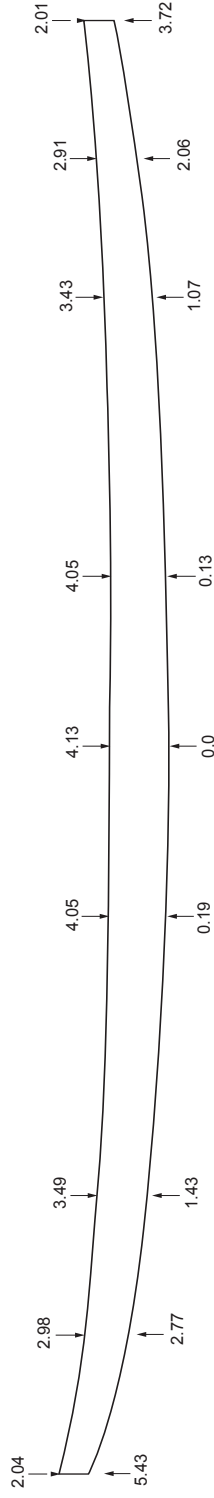
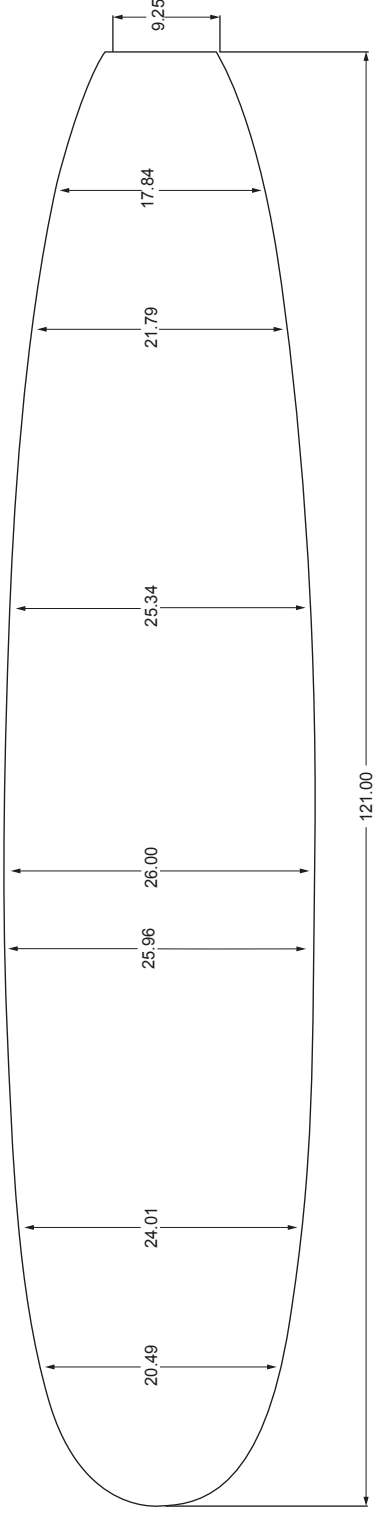

AVAILABLE DENSITIES:
*refer to density chart
STOCK STRINGER:
4mm poplar ply

BLANK DESCRIPTION
A blank made perfectly for your next longboard. With plenty of width and thickness it is perfect for a mellow cruiser or a high performance log. This blank is cut out of block EPS on a computer controlled hotwire machine to ensure the same blank dimensions everytime.

Updated 5-11-16

THIS INFORMATION IN THIS DRAWING IS THE SOLE PROPERTY OF MARKO FOAM ANY REPRODUCTION IN PART OR AS A WHOLE WITHOUT THE WRITTEN PERMISSION OF MARKO FOAM IS PROHIBITED

100% RECYCLABLE	
TITLE:	10'0" MK
SHAPER:	Marko Foam

10'6" MK

BLOCK CUT EPS

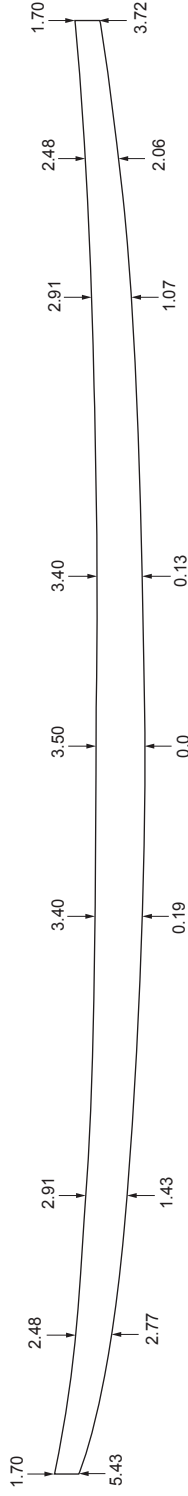
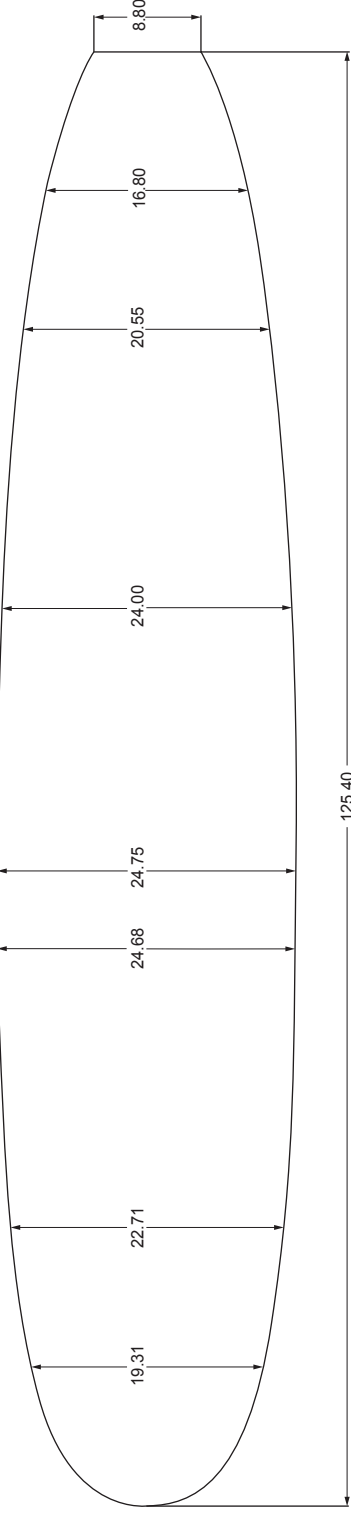

<p>AVAILABLE DENSITIES: *refer to density chart</p> <p>STOCK STRINGER: 1/8" Bass</p> <p>Updated 5-11-16</p>	<p>BLANK DESCRIPTION</p> <p>A blank made perfectly for your next longboard. With plenty of width and thickness it is perfect for a mellow cruiser or a high performance log. This blank is cut out of block EPS on a computer controlled hotwire machine to ensure the same blank dimensions everytime.</p>	<p>THIS INFORMATION IN THIS DRAWING IS THE SOLE PROPERTY OF MARKO FOAM</p> <p>ANY REPRODUCTION IN PART OR AS A WHOLE WITHOUT THE WRITTEN PERMISSION OF MARKO FOAM IS PROHIBITED</p>	<p>100% RECYCLABLE</p>
		<p>TITLE: MK - 10'6"</p>	<p>SHAPER: Marko Foam</p>



10'10" MK

BLOCK CUT EPS

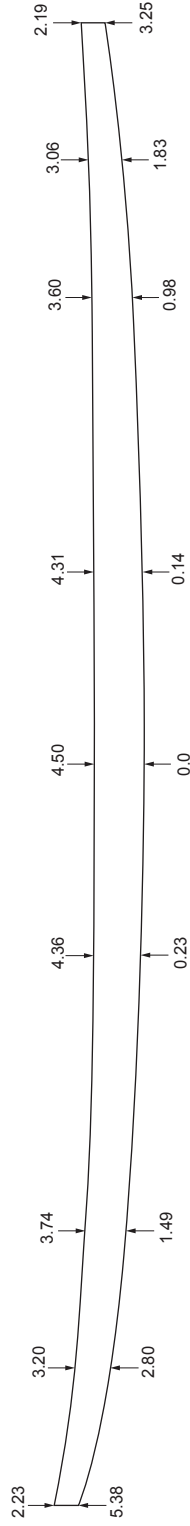
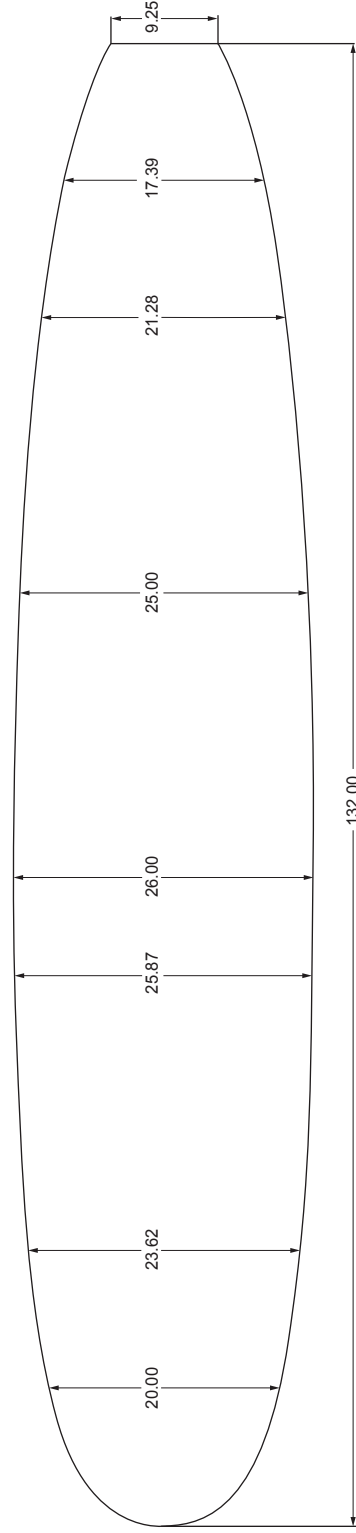

<p>AVAILABLE DENSITIES: *refer to density chart</p> <p>STOCK STRINGER: 1/8" Bass</p> <p style="text-align: right;">Updated 5-11-16</p>	<p>BLANK DESCRIPTION</p> <p>A blank made perfectly for your next longboard. With plenty of width and thickness it is perfect for a mellow cruiser or a high performance log. This blank is cut out of block EPS on a computer controlled hotwire machine to ensure the same blank dimensions everytime.</p>	<p>THIS INFORMATION IN THIS DRAWING IS THE SOLE PROPERTY OF MARKO FOAM ANY REPRODUCTION IN PART OR AS A WHOLE WITHOUT THE WRITTEN PERMISSION OF MARKO FOAM IS PROHIBITED</p>	<p style="text-align: center;">100% RECYCLABLE</p> <table border="1"> <tr> <td data-bbox="1277 193 1324 569">TITLE:</td> <td data-bbox="1324 193 1403 569">10'10" MK</td> </tr> <tr> <td data-bbox="1277 569 1324 801">SHAPER:</td> <td data-bbox="1324 569 1403 801">Marko Foam</td> </tr> </table>	TITLE:	10'10" MK	SHAPER:	Marko Foam
TITLE:	10'10" MK						
SHAPER:	Marko Foam						



8'0" GUN

BLOCK CUT EPS

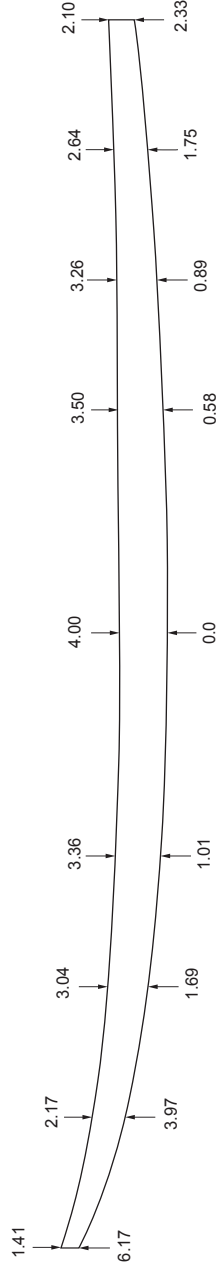
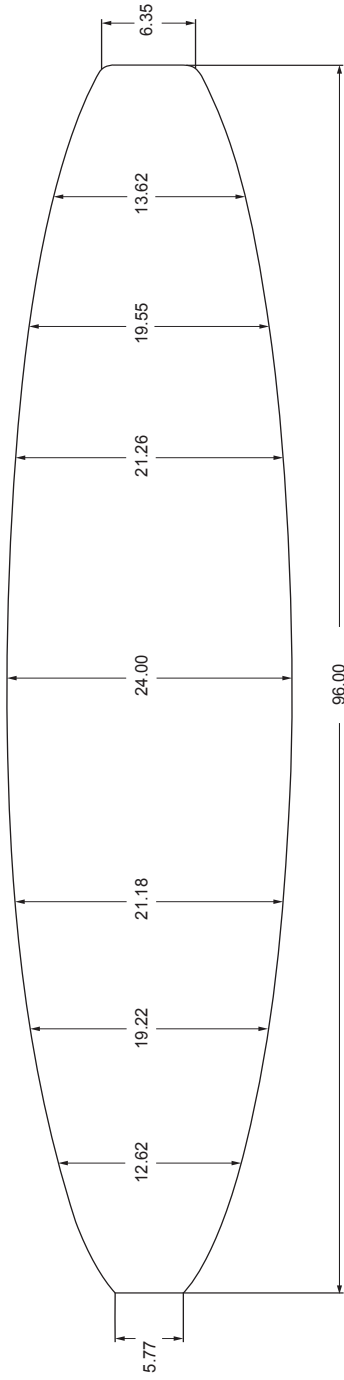

AVAILABLE DENSITIES:
*refer to density chart

BLANK DESCRIPTION
If your looking to charge some big waves you've found the right blank. With enough rocker to make the drop and an outline made for speed there's no wave the gun blanks can't handle. Go big or go home!

Updated 5-11-16

THIS INFORMATION IN THIS DRAWING IS THE SOLE PROPERTY OF MARKO FOAM ANY REPRODUCTION IN PART OR AS A WHOLE WITHOUT THE WRITTEN PERMISSION OF MARKO FOAM IS PROHIBITED

100% RECYCLABLE

TITLE:

8'0" Gun

Marko Foam

SHAPER:



9'6" GUN

BLOCK CUT EPS

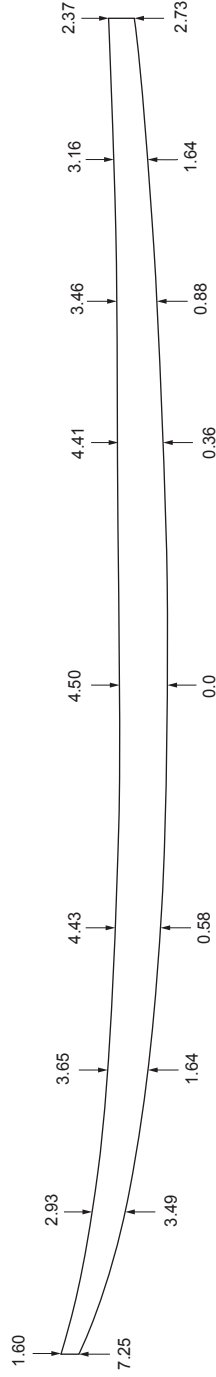
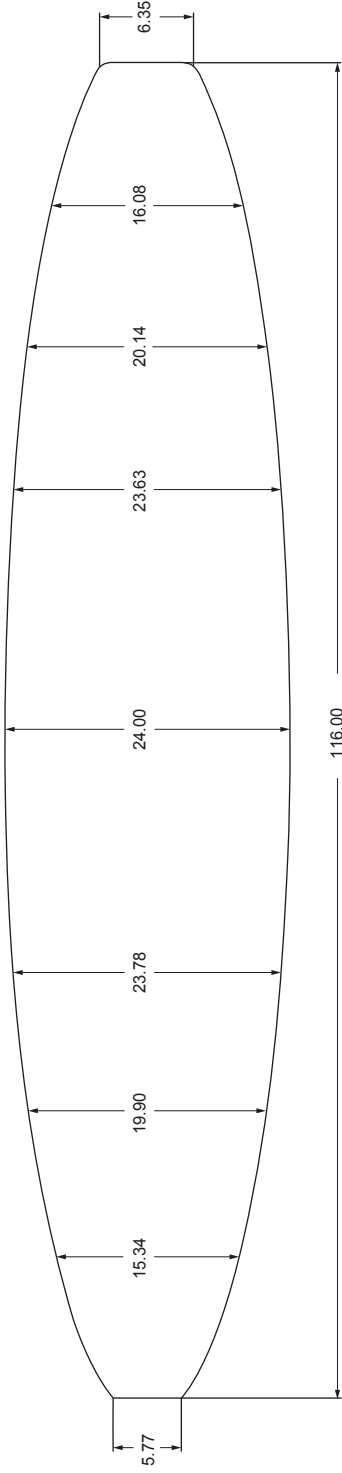

AVAILABLE DENSITIES:
*refer to density chart

Updated 5-11-16

BLANK DESCRIPTION

If your looking to charge some big waves you've found the right blank. With enough rocker to make the drop and an outline made for speed there's no wave the gun blanks can't handle. Go big or go home!

THIS INFORMATION IS THE SOLE PROPERTY OF MARKO FOAM ANY REPRODUCTION IN PART OR AS A WHOLE WITHOUT THE WRITTEN PERMISSION OF MARKO FOAM IS PROHIBITED

100% RECYCLABLE

TITLE:

9'6" Gun

SHAPER:

Marko Foam



10'6" GUN

BLOCK CUT EPS

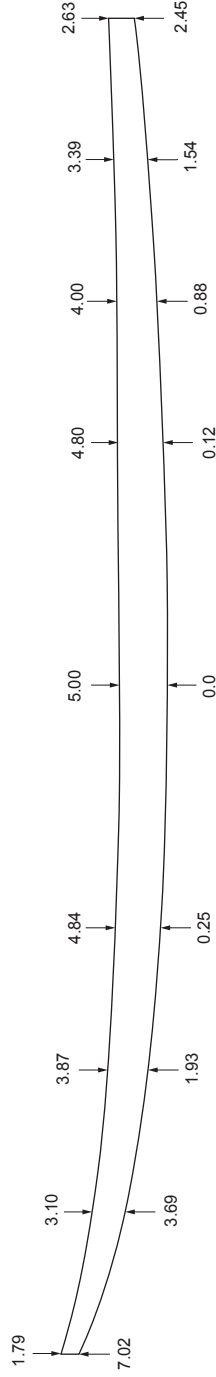
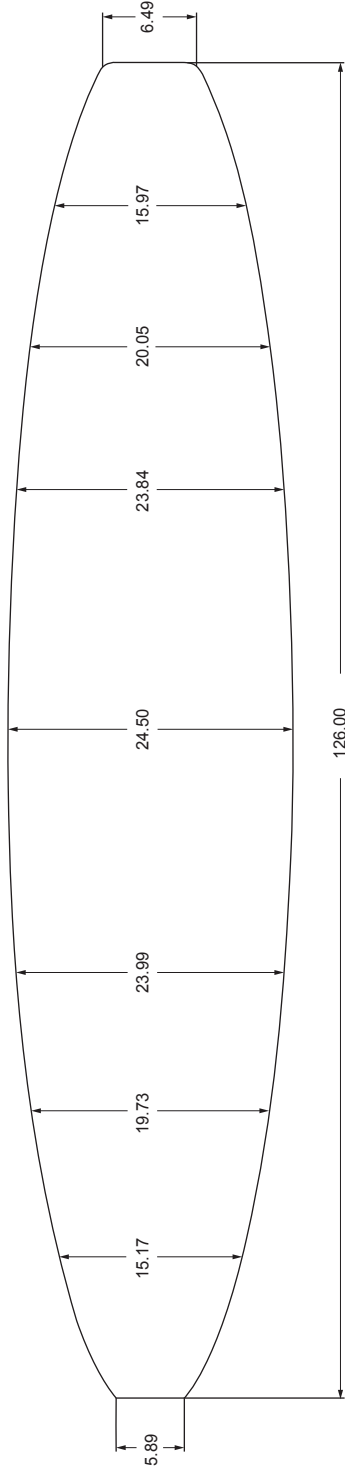

AVAILABLE DENSITIES:
*refer to density chart

BLANK DESCRIPTION
If your looking to charge some big waves you've found the right blank. With enough rocker to make the drop and an outline made for speed there's no wave the gun blanks can't handle. Go big or go home!

Updated 5-11-16

THIS INFORMATION IN THIS DRAWING IS THE SOLE PROPERTY OF MARKO FOAM ANY REPRODUCTION IN PART OR AS A WHOLE WITHOUT THE WRITTEN PERMISSION OF MARKO FOAM IS PROHIBITED

100% RECYCLABLE

TITLE: SHAPER:

10'6" Gun

Marko Foam

MOLDED PLANK

PRESSURE MOLDED EPP

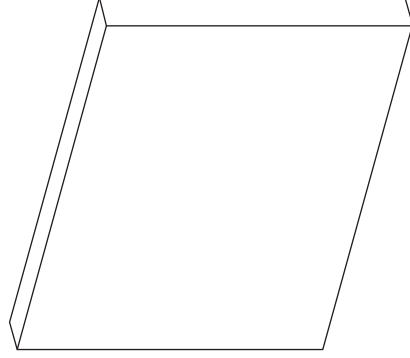
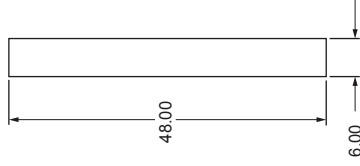
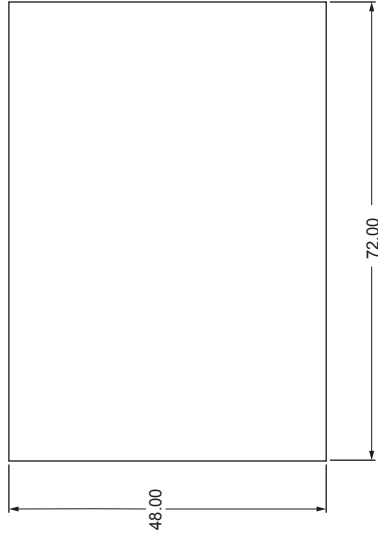
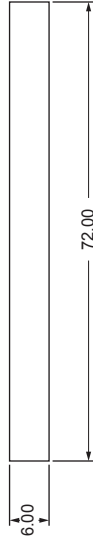

AVAILABLE DENSITIES:
1.3, 1.9

BLANK DESCRIPTION

This plank can be ordered as is or cut to specified dimensions. Good yield for many watersports applications.

MATERIAL:
EPP/EPE

Updated 5-11-16

THIS INFORMATION IS THE SOLE PROPERTY OF MARKO FOAM. ANY REPRODUCTION IN PART OR AS A WHOLE WITHOUT THE WRITTEN PERMISSION OF MARKO FOAM IS PROHIBITED.

100% RECYCLABLE

TITLE:

MOLDED
PLANK

SHAPER:

Marko Foam

MOLDED PLANK

PRESSURE MOLDED EPS/IFOAM

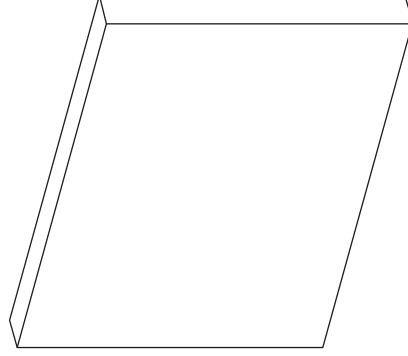
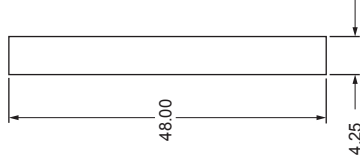
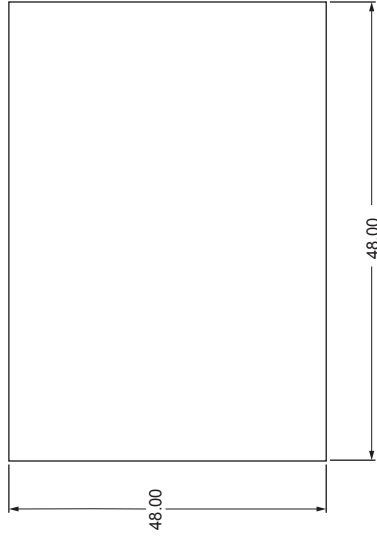

AVAILABLE DENSITIES:
1.3, 1.9

Updated 5-11-16

BLANK DESCRIPTION

This plank can be ordered as is or cut to specified dimensions. Good yield for many watersports applications.

MATERIAL:
EPS/IFOAM

THIS INFORMATION IN THIS DRAWING IS THE SOLE PROPERTY OF MARKO FOAM ANY REPRODUCTION IN PART OR AS A WHOLE WITHOUT THE WRITTEN PERMISSION OF MARKO FOAM IS PROHIBITED

100% RECYCLABLE

TITLE:

MOLDED
PLANK

SHAPER:

Marko Foam

SUP CATALOG



7'0" MK-SUP-STD

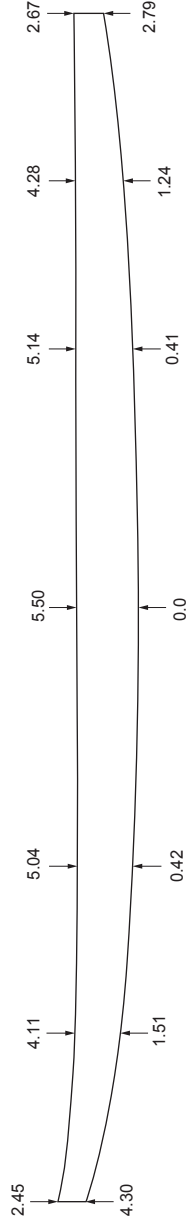
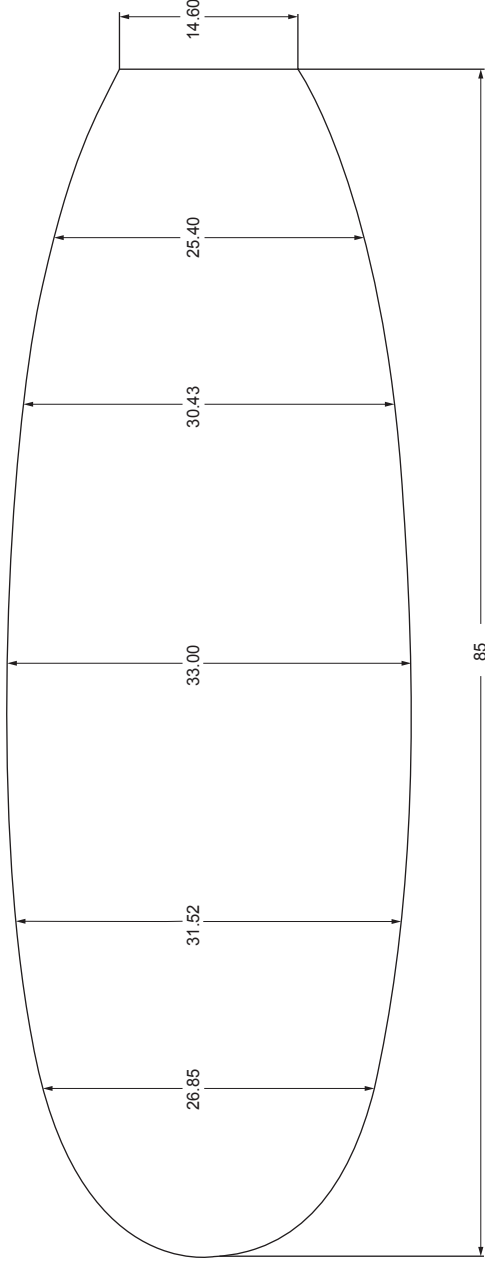

AVAILABLE DENSITIES:(PCF)
 *refer to density chart
STOCK STRINGER:
 1/8" Bass

BLANK DESCRIPTION
 This is a slab cut blank made out of Virgin EPS, glued with our stock rocker that can be adjusted to your specifications.

THIS INFORMATION IN THIS DRAWING IS THE SOLE PROPERTY OF MARKO FOAM ANY REPRODUCTION IN PART OR AS A WHOLE WITHOUT THE WRITTEN PERMISSION OF MARKO FOAM IS PROHIBITED

100% RECYCLABLE

TITLE:

SHAPER:

70" MK-SUP-STD

Marko Foam

Updated 5-11-16

8'0" MK-SUP-STD

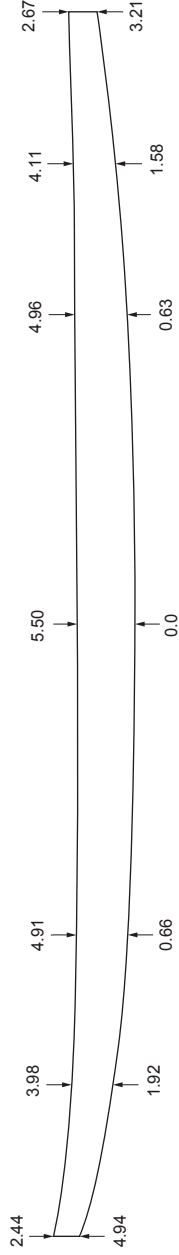
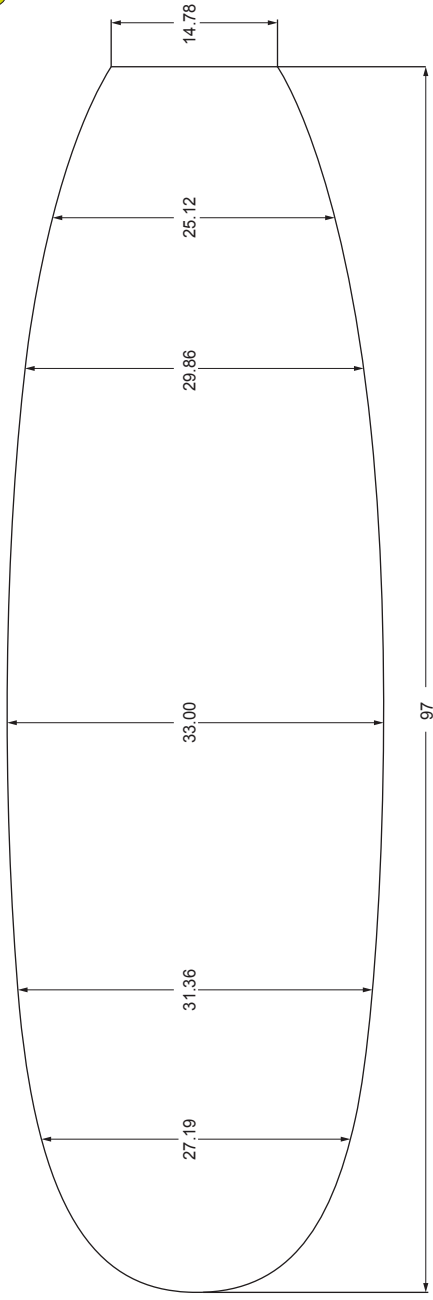

AVAILABLE DENSITIES:(PCF)
 *refer to density chart
STOCK STRINGER:
 1/8" Bass

BLANK DESCRIPTION
 This is a slab cut blank made out of Virgin EPS, glued with our stock rocker that can be adjusted to your specifications.

THIS INFORMATION IN THIS DRAWING IS THE SOLE PROPERTY OF MARKO FOAM ANY REPRODUCTION IN PART OR AS A WHOLE WITHOUT THE WRITTEN PERMISSION OF MARKO FOAM IS PROHIBITED

100% RECYCLABLE

TITLE:

SHAPER:
 Marko Foam

Updated 5-11-16

80" MK-SUP-STD



9'0" MK-SUP-STD

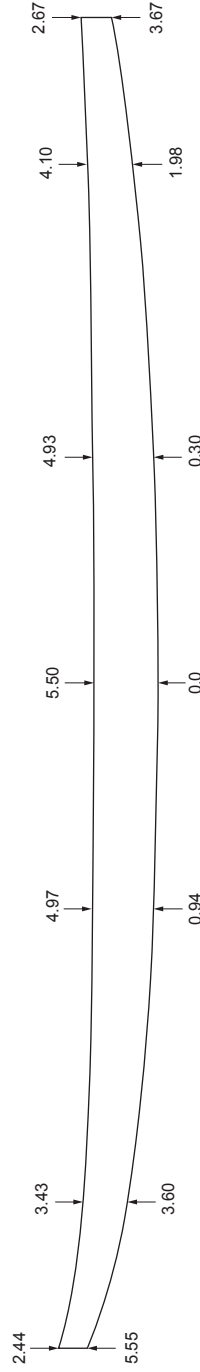
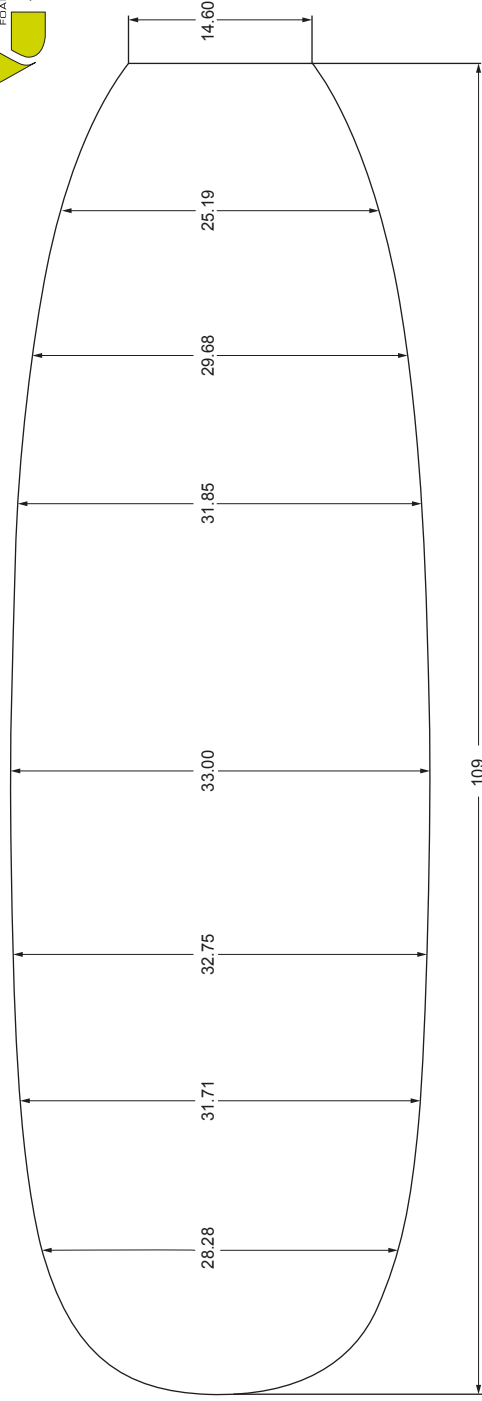

A AVAILABLE DENSITIES:(PCF)
 *refer to density chart
STOCK STRINGER:
 1/8" Bass

Updated 5-11-16

BLANK DESCRIPTION
 This is a slab cut blank made out of Virgin EPS, glued with our stock rocker that can be adjusted to your specifications.

THIS INFORMATION IN THIS DRAWING IS THE SOLE PROPERTY OF MARKO FOAM ANY REPRODUCTION IN PART OR AS A WHOLE WITHOUT THE WRITTEN PERMISSION OF MARKO FOAM IS PROHIBITED

100% RECYCLABLE

TITLE:

SHAPER:
 Marko Foam

90" MK-SUP-STD

10'0" MK-SUP-STD

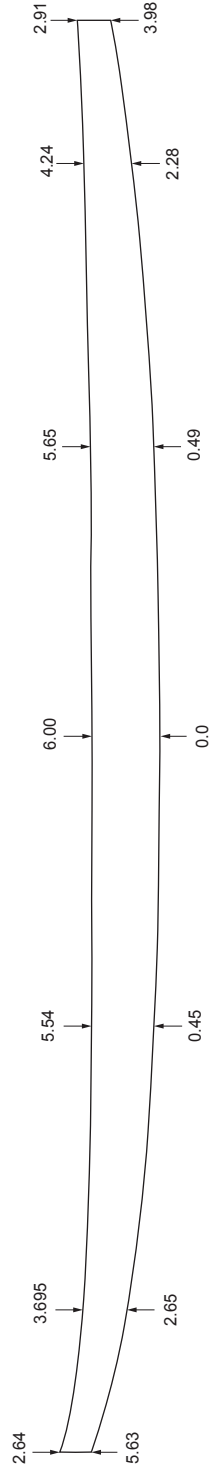
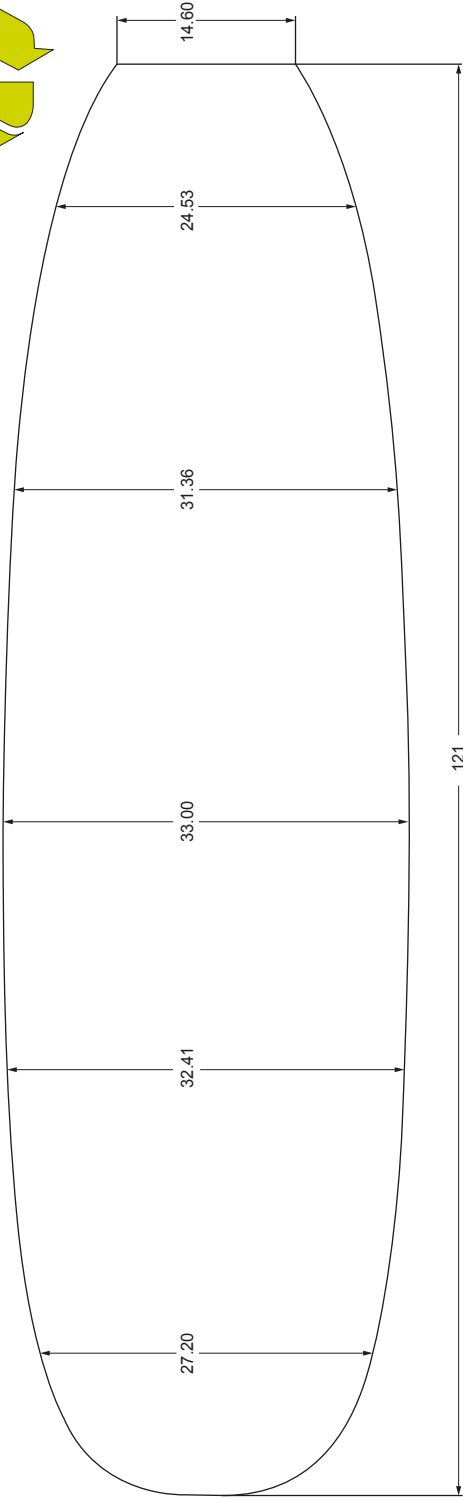

<p>A AVAILABLE DENSITIES: (PCF) *refer to density chart STOCK STRINGER: 1/8" Bass</p> <p>Updated 5-11-16</p>	<p>BLANK DESCRIPTION This is a slab cut blank made out of Virgin EPS, glued with our stock rocker that can be adjusted to your specifications.</p>	<p>THIS INFORMATION IN THIS DRAWING IS THE SOLE PROPERTY OF MARKO FOAM ANY REPRODUCTION IN PART OR AS A WHOLE WITHOUT THE WRITTEN PERMISSION OF MARKO FOAM IS PROHIBITED</p>	<p>100% RECYCLABLE</p> <p>TITLE: 10'0" MK-SUP-STD</p> <p>SHAPER: Marko Foam</p>
--	---	--	--

11'0" MK-SUP-STD

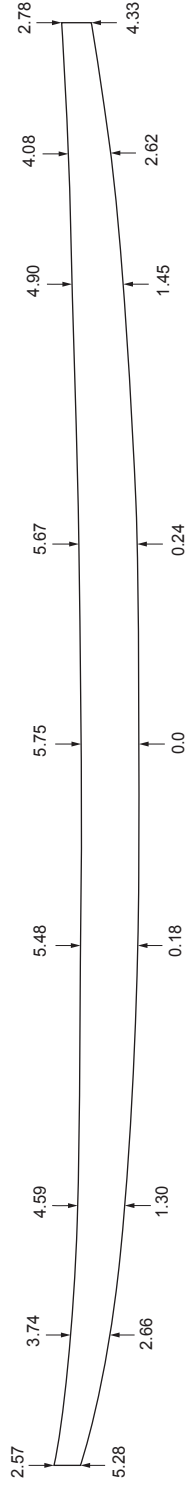
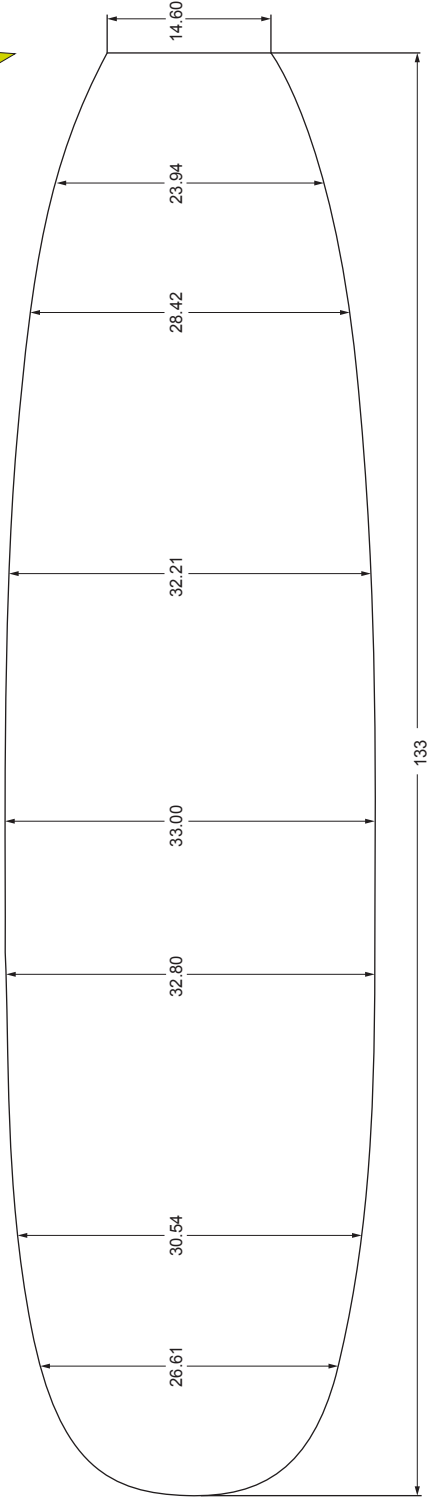

<p>A AVAILABLE DENSITIES:(PCF) *refer to density chart STOCK STRINGER: 1/8" Bass</p> <p>Updated 5-11-16</p>	<p>BLANK DESCRIPTION This is a slab cut blank made out of Virgin EPS, glued with our stock rocker that can be adjusted to your specifications.</p>	<p>THIS INFORMATION IN THIS DRAWING IS THE SOLE PROPERTY OF MARKO FOAM ANY REPRODUCTION IN PART OR AS A WHOLE WITHOUT THE WRITTEN PERMISSION OF MARKO FOAM IS PROHIBITED</p>	<p>100% RECYCLABLE</p> <p>TITLE: 11'0" MK-SUP-STD</p> <p>SHAPER: Marko Foam</p>
---	---	--	--

12'0" MK-SUP-STD

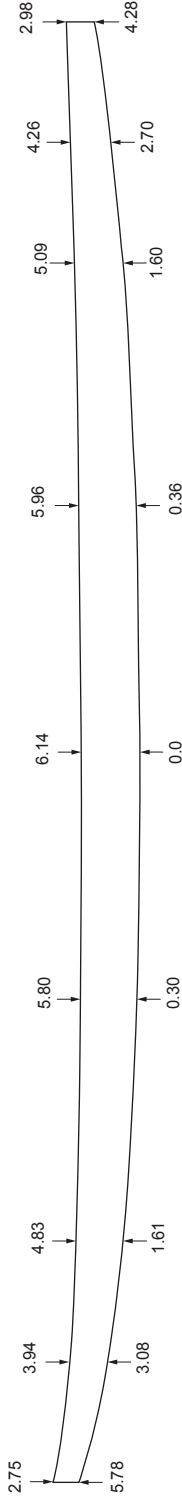
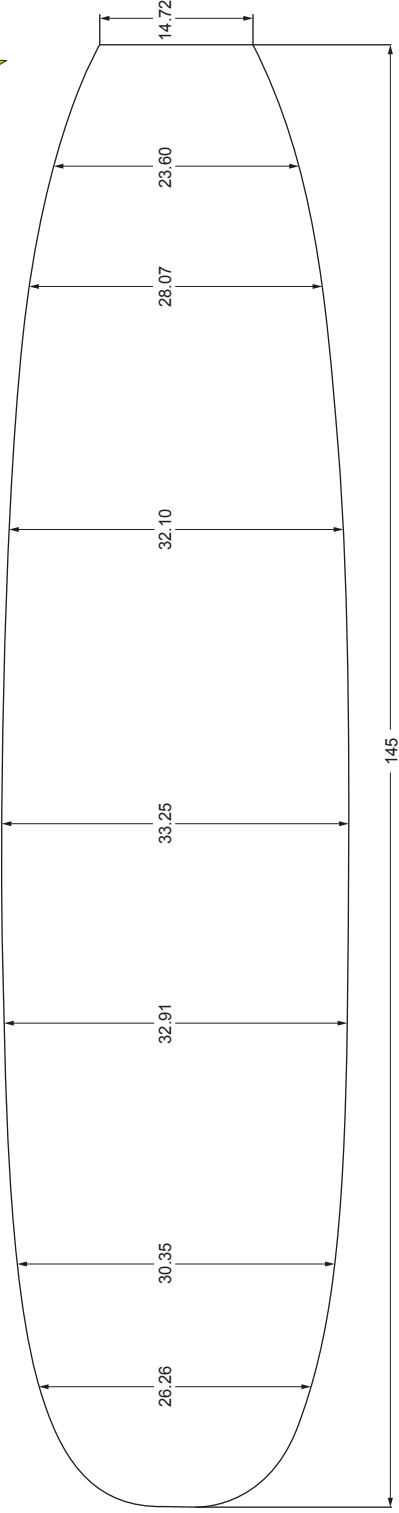

<p>A AVAILABLE DENSITIES:(PCF) *refer to density chart STOCK STRINGER: 1/8" Bass</p> <p style="text-align: right;">Updated 5-11-16</p>	<p>BLANK DESCRIPTION This is a slab cut blank made out of Virgin EPS, glued with our stock rocker that can be adjusted to your specifications.</p>	<p>THIS INFORMATION IN THIS DRAWING IS THE SOLE PROPERTY OF MARKO FOAM ANY REPRODUCTION IN PART OR AS A WHOLE WITHOUT THE WRITTEN PERMISSION OF MARKO FOAM IS PROHIBITED</p>	<p style="text-align: center;">100% RECYCLABLE</p> <table border="1" style="width: 100%;"> <tr> <td style="width: 50%;">TITLE: 12'0" MK-SUP-STD</td> <td style="width: 50%;">SHAPER: Marko Foam</td> </tr> </table>	TITLE: 12'0" MK-SUP-STD	SHAPER: Marko Foam
TITLE: 12'0" MK-SUP-STD	SHAPER: Marko Foam				

12'6" MK-SUP-STD

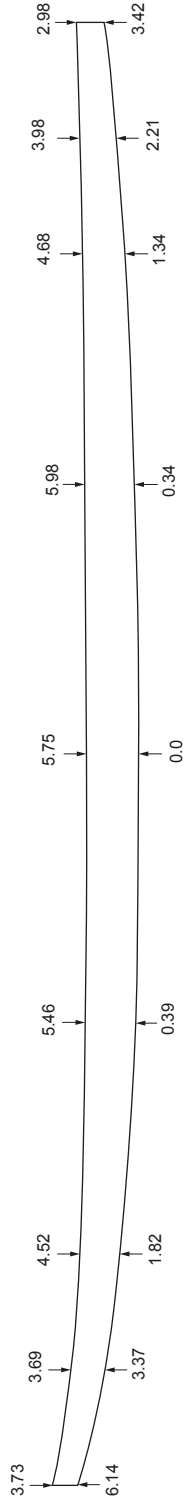
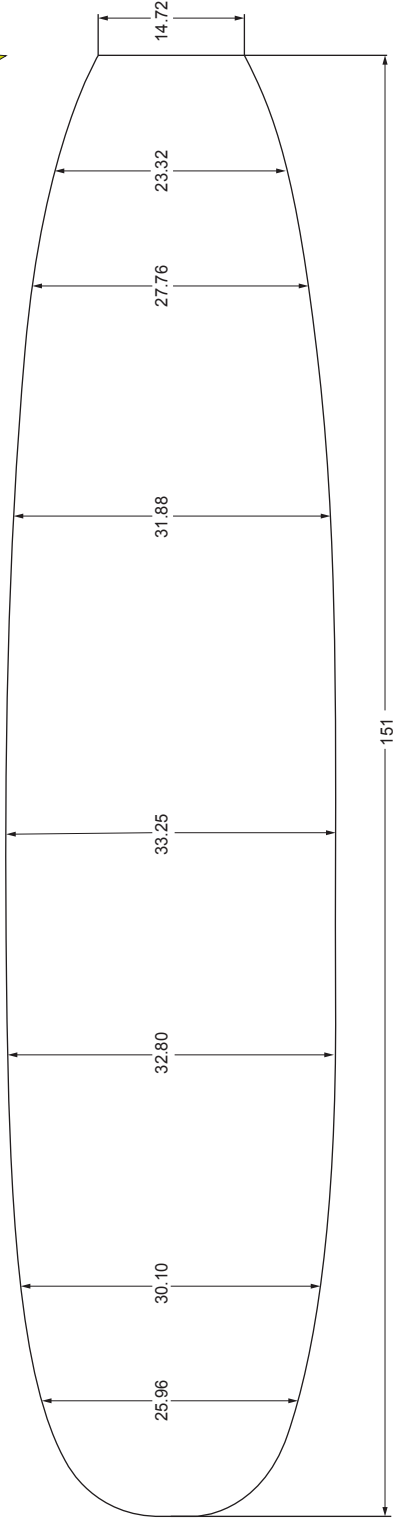

<p>A AVAILABLE DENSITIES:(PCF) *refer to density chart STOCK STRINGER: NONE</p> <p style="text-align: right;">Updated 5-11-16</p>	<p>BLANK DESCRIPTION This is a slab cut blank made out of Virgin EPS, glued with our stock rocker that can be adjusted to your specifications.</p>	<p>THIS INFORMATION IN THIS DRAWING IS THE SOLE PROPERTY OF MARKO FOAM ANY REPRODUCTION IN PART OR AS A WHOLE WITHOUT THE WRITTEN PERMISSION OF MARKO FOAM IS PROHIBITED</p>	<p style="text-align: center; font-size: 2em;">100% RECYCLABLE</p> <table border="1" style="width: 100%;"> <tr> <td data-bbox="1277 193 1324 569"> <p>TITLE: 12'6" MK-SUP-STD</p> </td> <td data-bbox="1324 193 1403 569"> <p>SHAPER: Marko Foam</p> </td> </tr> </table>	<p>TITLE: 12'6" MK-SUP-STD</p>	<p>SHAPER: Marko Foam</p>
<p>TITLE: 12'6" MK-SUP-STD</p>	<p>SHAPER: Marko Foam</p>				

12'6" MK-SUP-MONO

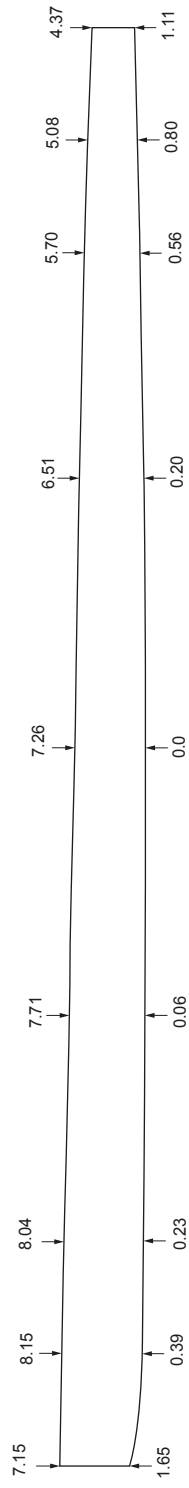
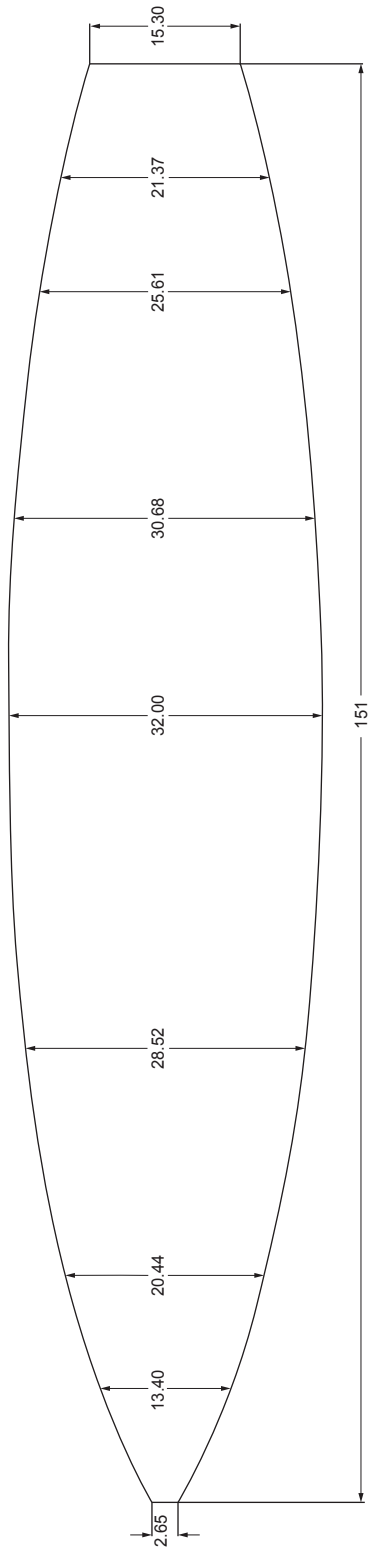

A AVAILABLE DENSITIES:(PCF)
 *refer to density chart
STOCK STRINGER:
 NONE

BLANK DESCRIPTION
 This is a slab cut blank made out of Virgin EPS, glued with our stock rocker that can be adjusted to your specifications.

THIS INFORMATION IN THIS DRAWING IS THE SOLE PROPERTY OF MARKO FOAM ANY REPRODUCTION IN PART OR AS A WHOLE WITHOUT THE WRITTEN PERMISSION OF MARKO FOAM IS PROHIBITED

100% RECYCLABLE

TITLE: 12'6" MK-SUP-MONO
SHAPER: Marko Foam

Updated 5-11-16

14'0" MK-SUP-MONO

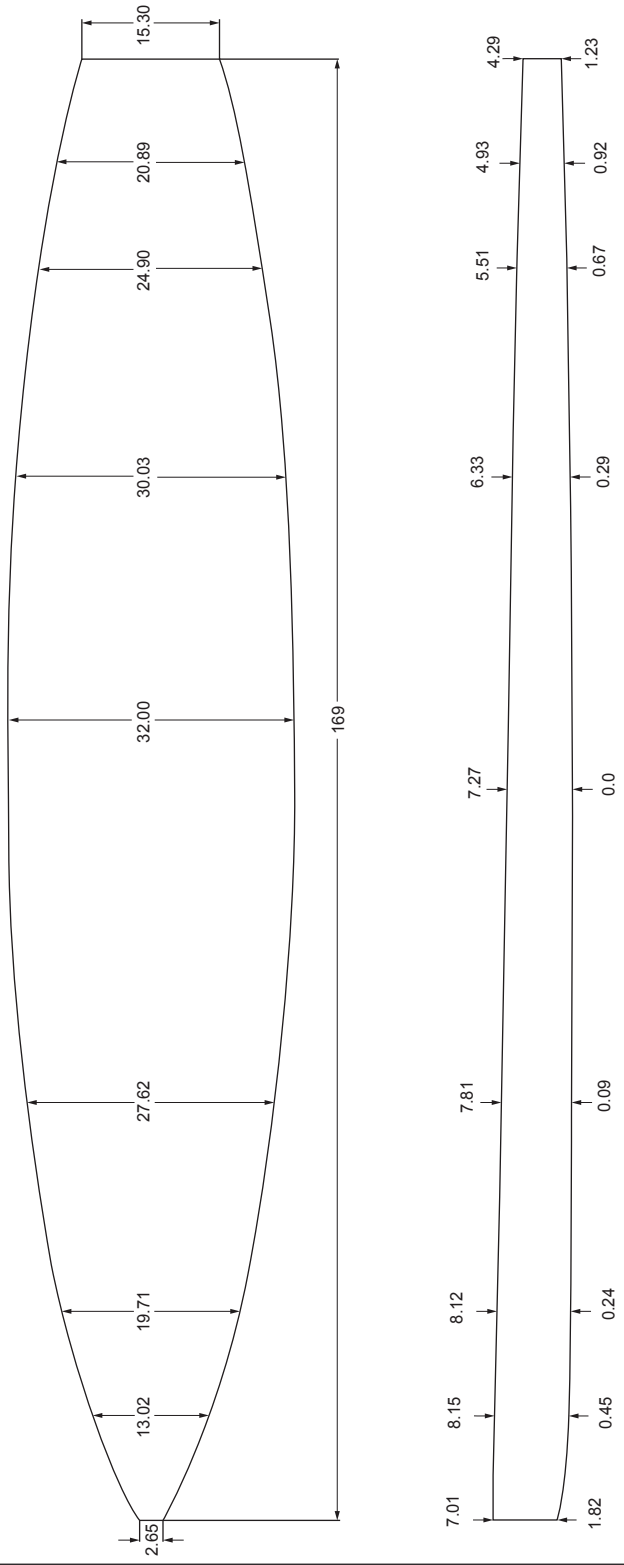

A AVAILABLE DENSITIES:(PCF)

*refer to density chart

STOCK STRINGER:

NONE

BLANK DESCRIPTION

This is a slab cut blank made out of Virgin EPS, glued with our stock rocker that can be adjusted to your specifications.

THIS INFORMATION IN THIS DRAWING IS THE SOLE PROPERTY OF MARKO FOAM ANY REPRODUCTION IN PART OR AS A WHOLE WITHOUT THE WRITTEN PERMISSION OF MARKO FOAM IS PROHIBITED

100% RECYCLABLE

TITLE:

14'0" MK-SUP-MONO

SHAPER:

Marko Foam

Updated 5-11-16