



MAKING A WORLD OF DIFFERENCE IN THE WATER

www.markofoamblanks.com

2017 BLANK CATALOG

1.949.417.3307

info@markofoam.com



Density Chart

Blank Description	VIRGIN EPS			ENVIRO-FOAM			I-FOAM			EFC
MOLDED BLANKS	1.7#	2.0#	2.3#	1.7#	2.0#	2.3#	1.7#	2.0#	2.3#	2.3
Wakesurf Regular		X								
Wakesurf Thick		X								
6'0 M Regular		X								
6'0" M Thick	X	X								
6'0 FISH										X
6'1 Pescado		X								
62 H New		X								
6'2 Thick		X								
6'2 SB										X
6'4 TP		X								
6'4 Thick	X	X	X		X			X	X	
6'6 Halibut		X								
6'6 M	X	X			X					
6'8 SB										X
6'8 JJ		X								
6'8 Thick	X	X						X		
6'10 FISH										X
7'2 M		X								
7'2 M Thick		X			X					
7'4 Halibut		X								
7'5 Machin All		X	X							
7'6 JJ		X								
7'6 Thick		X	X							
8'5 Universal		X								
8'5 Machinal all	X	X	X							
9'1 JJ		X								
9'1 Machine All	X	X	X		X			X		
BLOCK CUT	1.0#	1.5#	2#	Gun Blanks: Our Gun Blanks are available in 2.0# and 2.5# densities up to 12' and are Block cut. SUP Blanks: Our SUP blanks are available in 1.5# up to 12'0" and 1.0# up to 18'0" and are Block cut.						
MK 7'0		X	X							
MK 9'6		X	X							
MK 10'0	X	X	X							
MK 10'10"	X	X	X							

*Additional Densities available upon request

Info@markofoam.com

Rev. 3/30/17

WAKESURF REGULAR

PRESSURE MOLDED EPS BLANKS

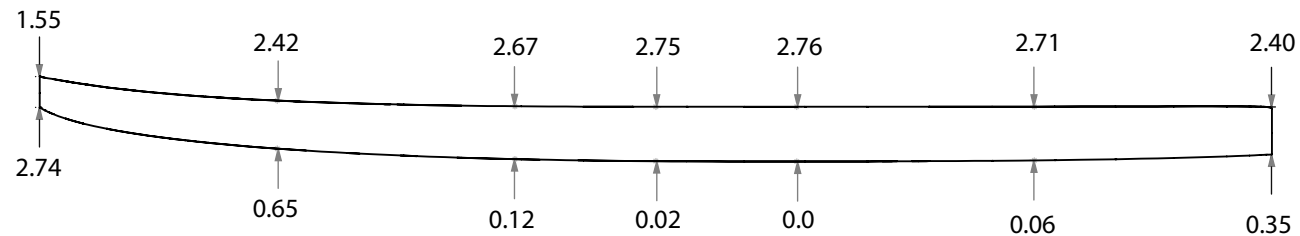
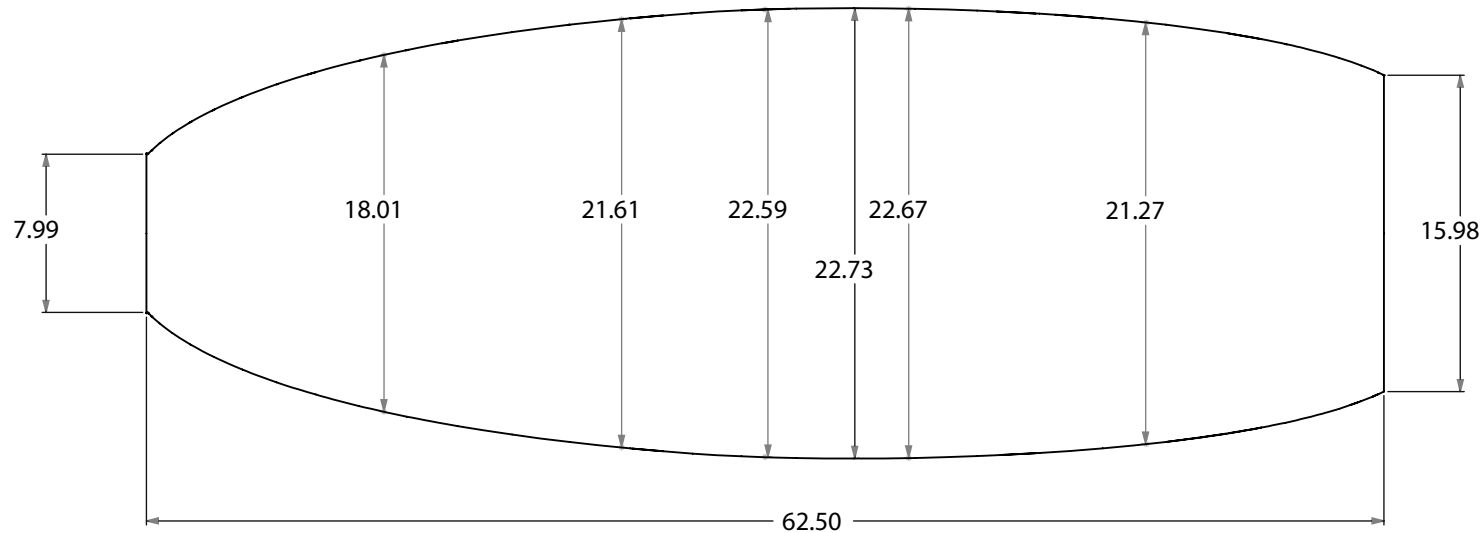

AVAILABLE DENSITIES:

*refer to density chart

STOCK STRINGER:

4mm poplar ply

Updated 5-11-16

SHAPER'S COMMENTS:

No waves, no problem! With help from customers and riders alike we have designed the perfect blank specifically made for the wakesurf world. From the Ocean to the Lake this Wakesurf blank has all you need to make yourself a killer custom wakesurf board.

THIS INFORMATION IN THIS DRAWING IS THE SOLE PROPERTY OF marko foam ANY REPRODUCTION IN PART OR AS A WHOLE WITHOUT THE WRITTEN PERMISSION OF marko foam IS PROHIBITED

100% RECYCLABLE

TITLE:
Wakesurf Regular

SHAPER:
Marko Foam

WAKESURF THICK

PRESSURE MOLDED EPS BLANKS

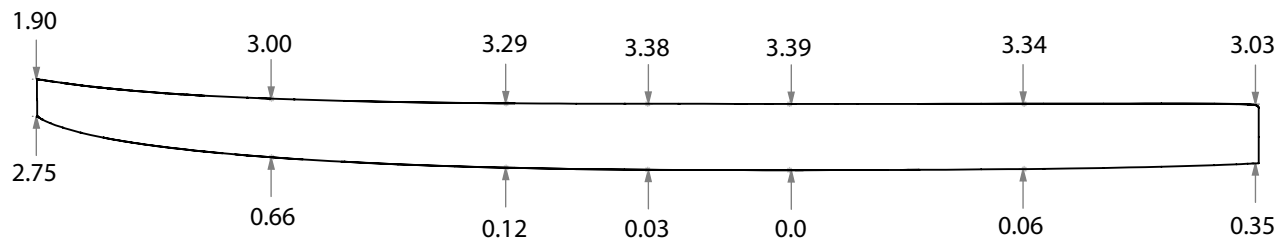
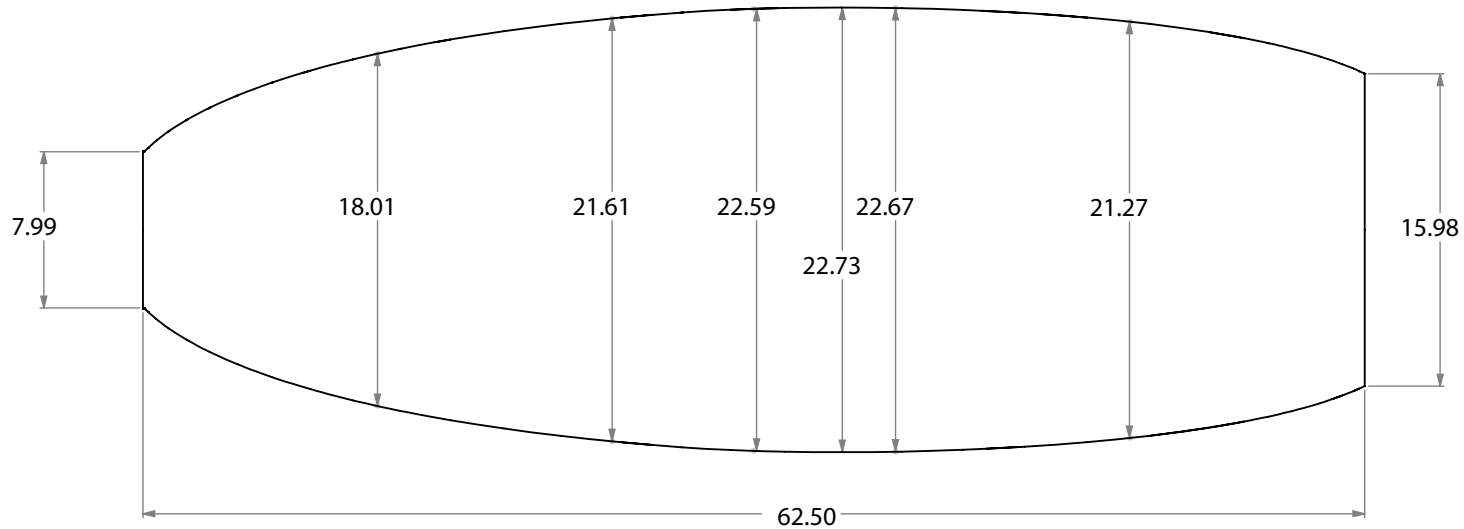

AVAILABLE DENSITIES:

*refer to density chart

STOCK STRINGER:

4mm poplar ply

Updated 5-11-16

SHAPER'S COMMENTS:

No waves, no problem! With help from customers and riders alike we have designed the perfect blank specifically made for the wakesurf world. From the Ocean to the Lake this Wakesurf blank has all you need to make yourself a killer custom wakesurf board.

THIS INFORMATION IN THIS DRAWING IS THE SOLE PROPERTY OF marko foam ANY REPRODUCTION IN PART OR AS A WHOLE WITHOUT THE WRITTEN PERMISSION OF marko foam IS PROHIBITED

100% RECYCLABLE

TITLE:

Wakesurf Thick

SHAPER:

Marko Foam

6'0" M-REGULAR

PRESSURE MOLDED EPS BLANKS

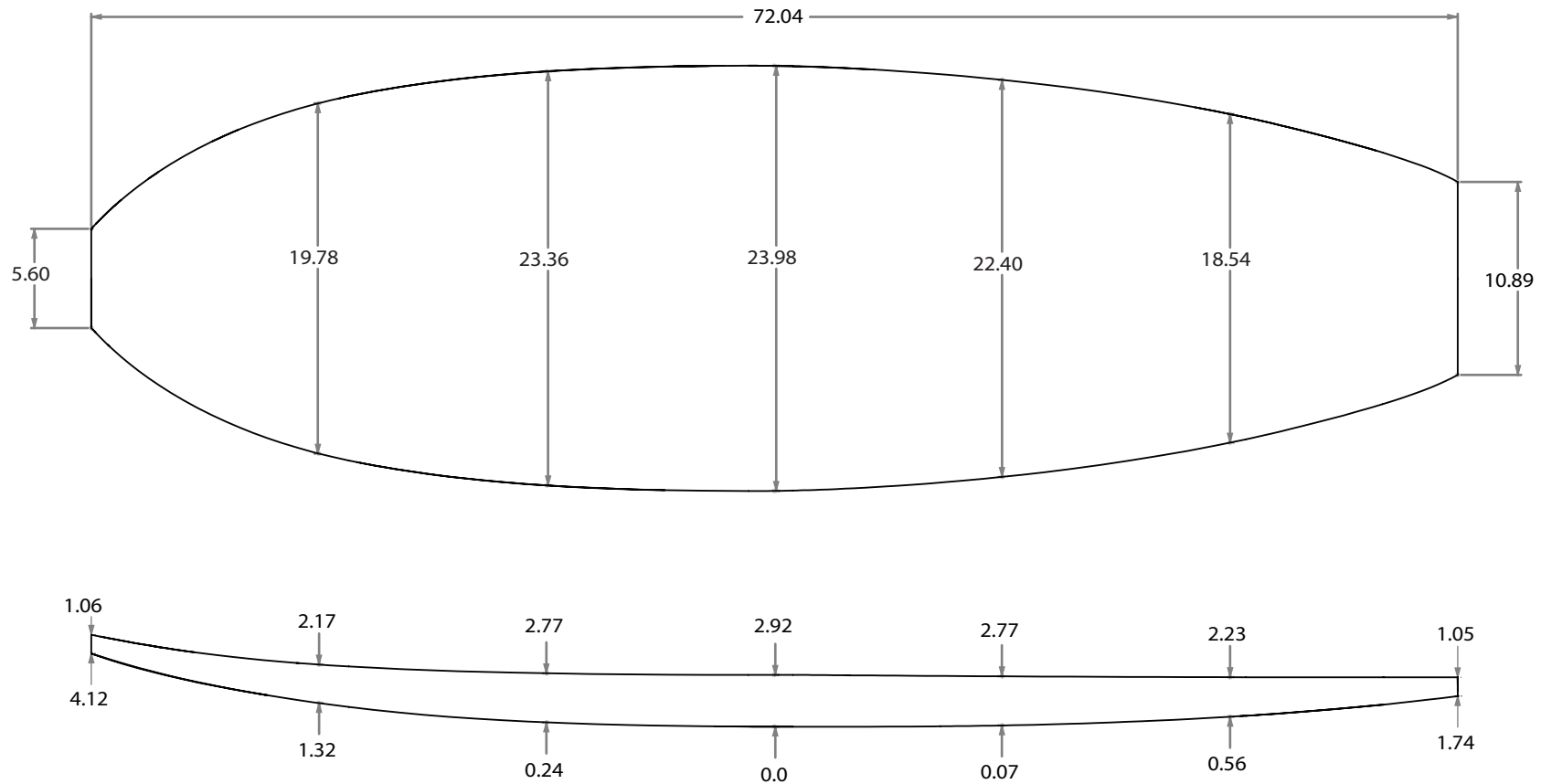

AVAILABLE DENSITIES:

*refer to density chart

STOCK STRINGER:

4mm poplar ply

Updated 5-11-16

SHAPER'S COMMENTS:

"From your cruiser fish to your groveling performance short board the 6'0" m regular can do it all. This new simplified molded blank, is perfect for almost all boards. The flat wide deck and bottom, square rails, and relaxed rocker caters to a wide variety of boards making it go to blank for the CNC Machine and Shapers alike. This blank is available stringerless or with our variety of stock stringers."

THIS INFORMATION IN THIS DRAWING IS THE SOLE PROPERTY OF marko foam ANY REPRODUCTION IN PART OR AS A WHOLE WITHOUT THE WRITTEN PERMISSION OF marko foam IS PROHIBITED

100% RECYCLABLE

TITLE:
6'0" M Regular

SHAPER:
Marko Foam

6'0" M-THICK

PRESSURE MOLDED EPS BLANKS

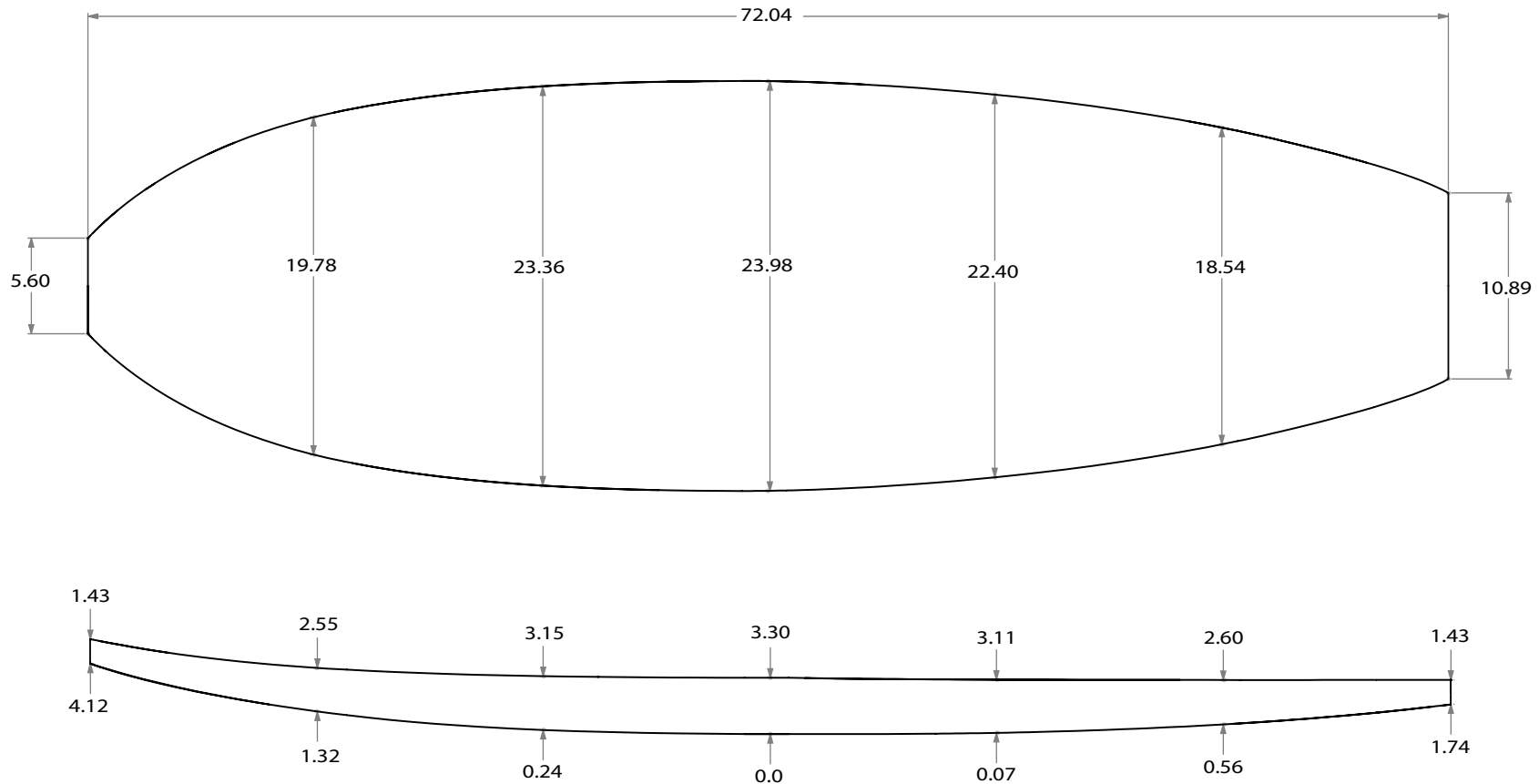

AVAILABLE DENSITIES:

*refer to density chart

STOCK STRINGER:

4mm poplar ply

Updated 5-11-16

SHAPER'S COMMENTS:

"From your cruiser fish to your groveling performance short board the 6'0" m thick can do it all. °is new simplified molded blank, is perfect for almost all boards. The wide deck and bottom, square rails, and relaxed rocker caters to a wide variety of boards making it go to blank for the CNC Machine and Shapers alike. °is blank is available stringerless or with our variety of stock stringers."

THIS INFORMATION IN THIS DRAWING IS THE SOLE PROPERTY OF marko foam ANY REPRODUCTION IN PART OR AS A WHOLE WITHOUT THE WRITTEN PERMISSION OF marko foam IS PROHIBITED

100% RECYCLABLE

TITLE:

6'0" M Thick

SHAPER:

Marko Foam

6'1" PESCADO

PRESSURE MOLDED EPS BLANKS

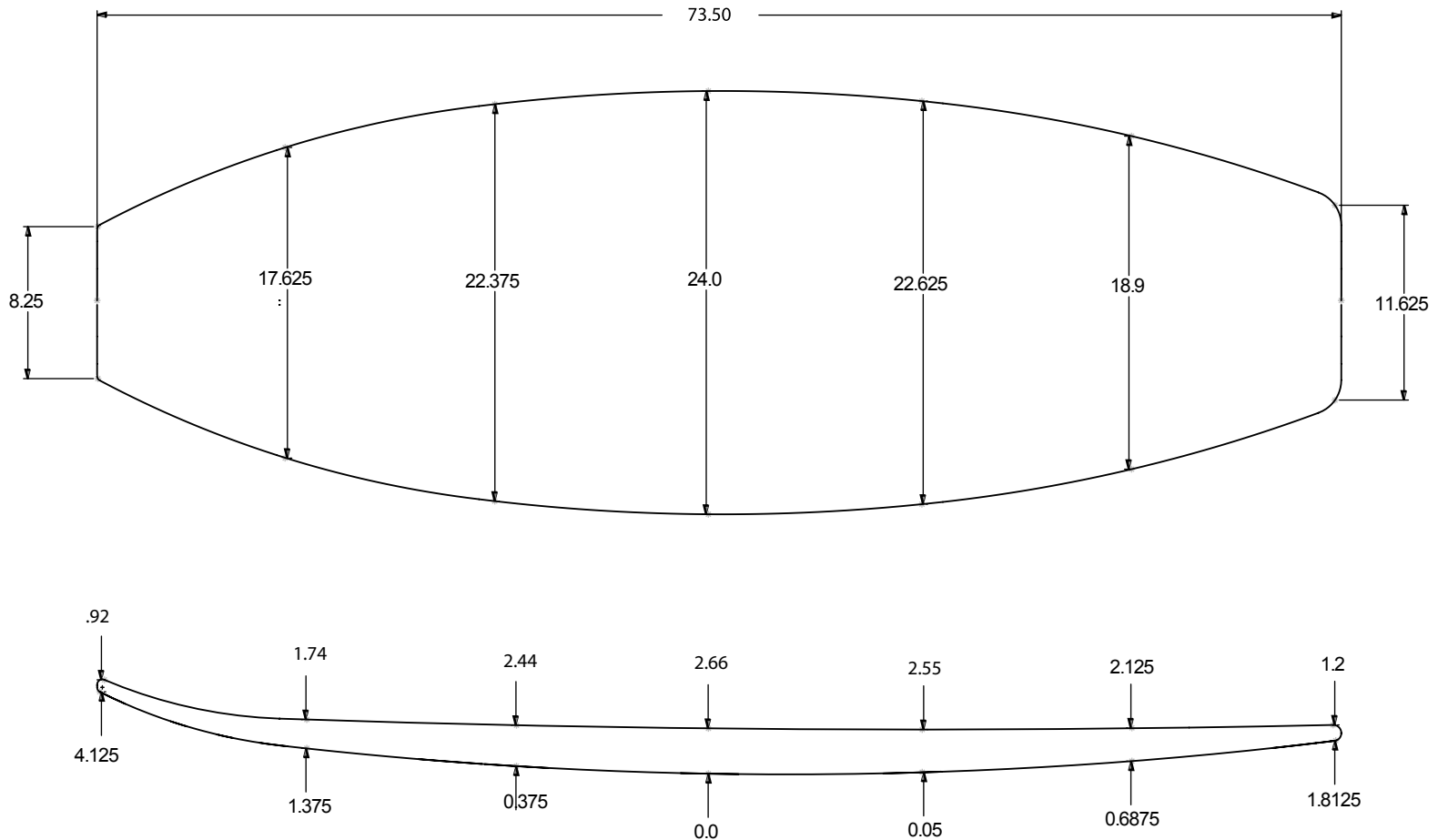

AVAILABLE DENSITIES:

*refer to density chart

STOCK STRINGER:

4mm poplar ply

Not Available in a Stringerless Blank

Updated 5-11-16

SHAPER'S COMMENTS:

Hybrid fish style blank with plenty of width throughout.
Good for hand shaping or tight tolerance machining.

**THIS INFORMATION IN
THIS DRAWING IS THE
SOLE PROPERTY OF
marko foam
ANY REPRODUCTION IN
PART OR AS A WHOLE
WITHOUT THE WRITTEN
PERMISSION OF
marko foam
IS PROHIBITED**

100% RECYCLABLE

TITLE:

6'1" PESCADO

SHAPER:

Marko Foam

6'2" H-NEW

PRESSURE MOLDED EPS BLANKS

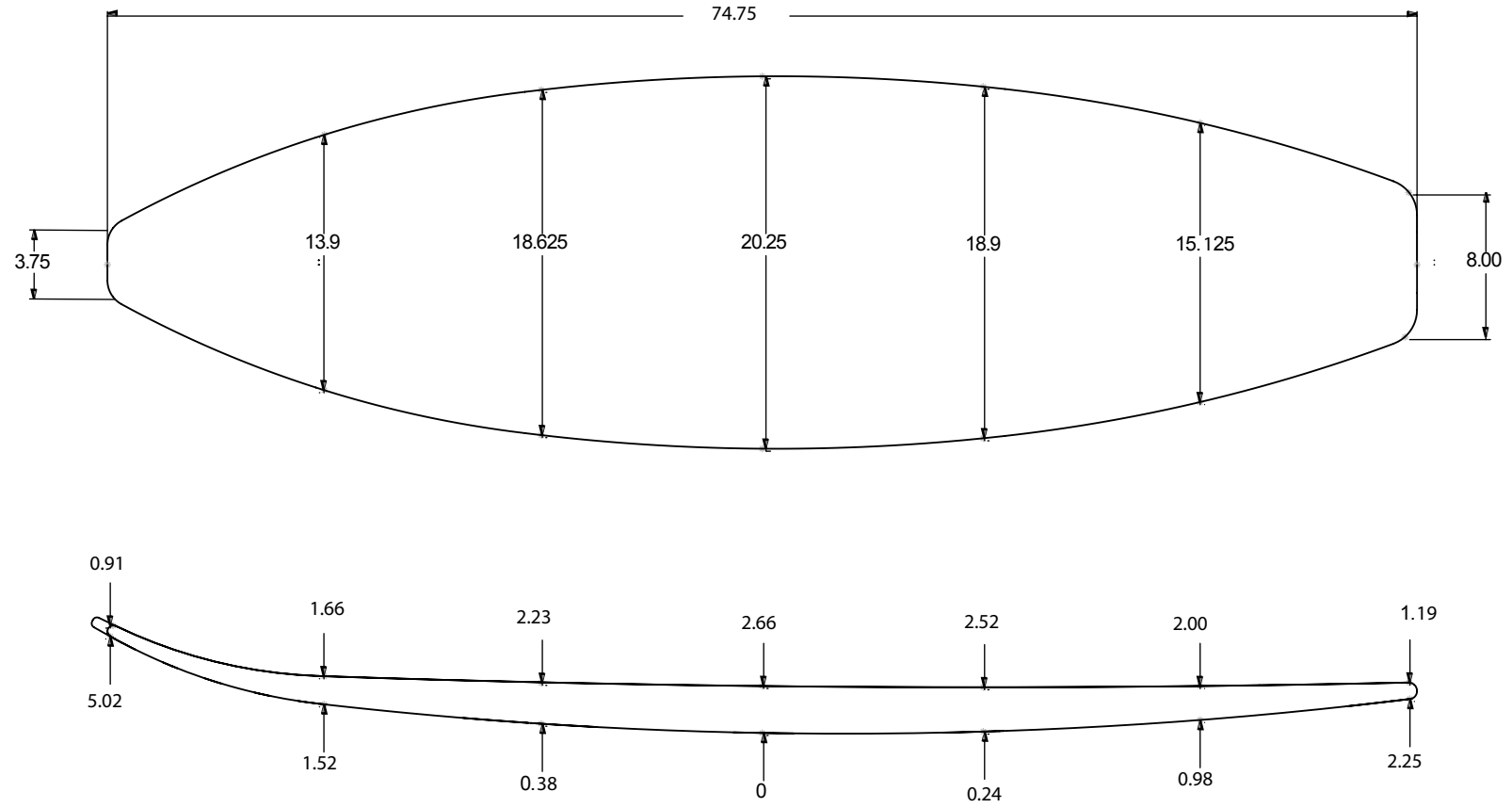

AVAILABLE DENSITIES:
*refer to density chart
STOCK STRINGER:
4mm poplar ply

Updated 5-11-16

SHAPER'S COMMENTS:
Standard short board blank made for hand shaping or tight tolerance machining.

THIS INFORMATION IN THIS DRAWING IS THE SOLE PROPERTY OF marko foam ANY REPRODUCTION IN PART OR AS A WHOLE WITHOUT THE WRITTEN PERMISSION OF marko foam IS PROHIBITED

100% RECYCLABLE

TITLE:	SHAPER:
6'2" H-NEW	Marko Foam

6'2" THICK

PRESSURE MOLDED EPS BLANKS

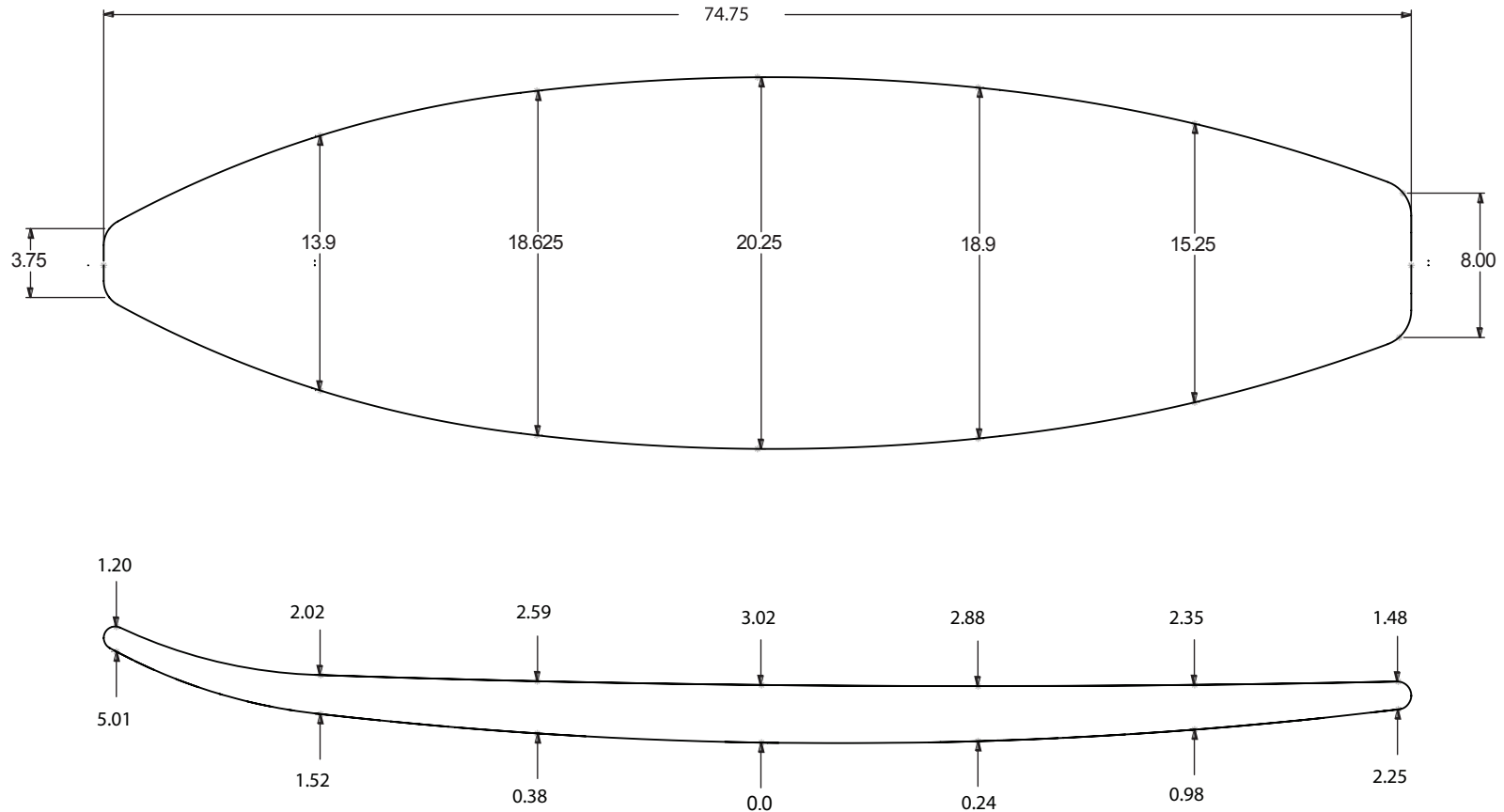

AVAILABLE DENSITIES:

*refer to density chart

STOCK STRINGER:

4mm poplar ply

Updated 5-11-16

SHAPER'S COMMENTS:

This blank is designed for machine shaping and has extra material in the nose area for thicker models.

THIS INFORMATION IN THIS DRAWING IS THE SOLE PROPERTY OF marko foam ANY REPRODUCTION IN PART OR AS A WHOLE WITHOUT THE WRITTEN PERMISSION OF marko foam IS PROHIBITED

100% RECYCLABLE

TITLE:

6'2" THICK

SHAPER:

Marko Foam

6'4" TP

PRESSURE MOLDED EPS BLANKS

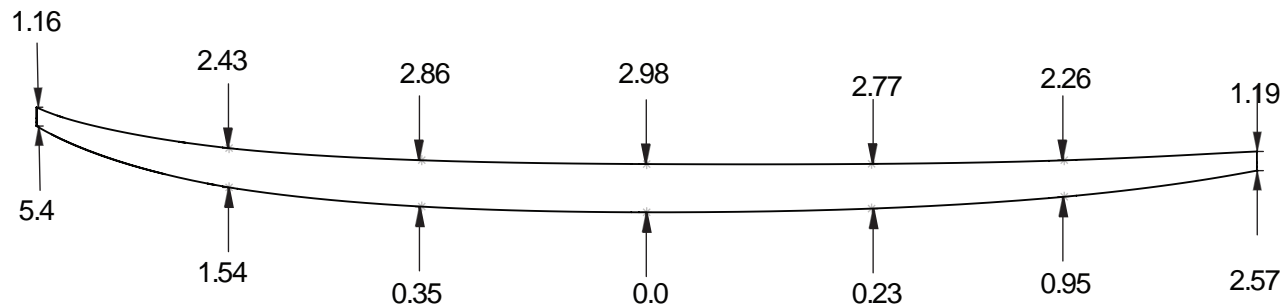
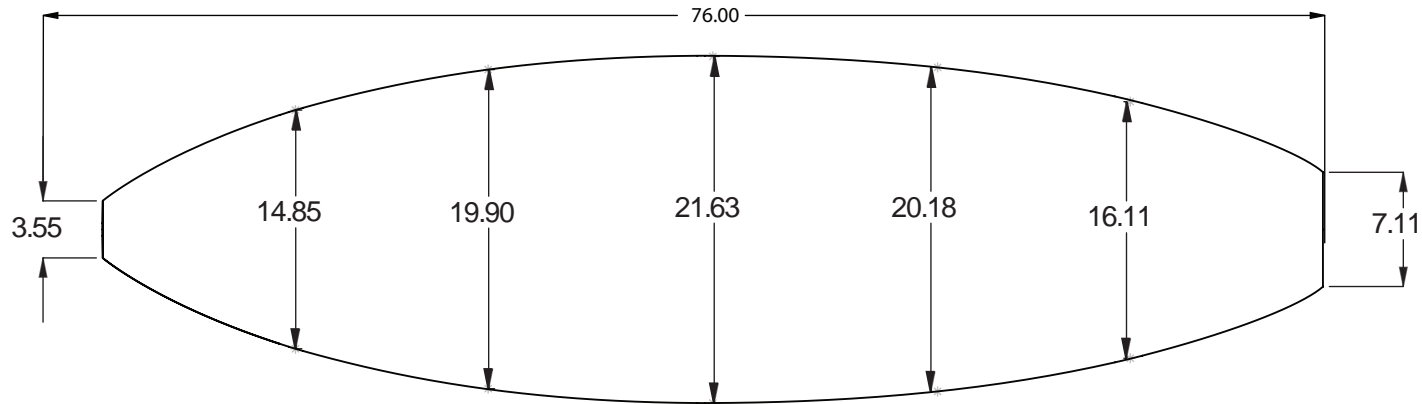

AVAILABLE DENSITIES:

*refer to density chart

STOCK STRINGER:

4mm poplar ply

Updated 5-11-16

SHAPER'S COMMENTS:

This blank is made for hand or machine shaping. Great all purpose "go to" blank.

THIS INFORMATION IN THIS DRAWING IS THE SOLE PROPERTY OF marko foam ANY REPRODUCTION IN PART OR AS A WHOLE WITHOUT THE WRITTEN PERMISSION OF marko foam IS PROHIBITED

100% RECYCLABLE

TITLE:	SHAPER:
6'4" TP	T. PATTERSON

6'4" THICK

PRESSURE MOLDED EPS BLANKS

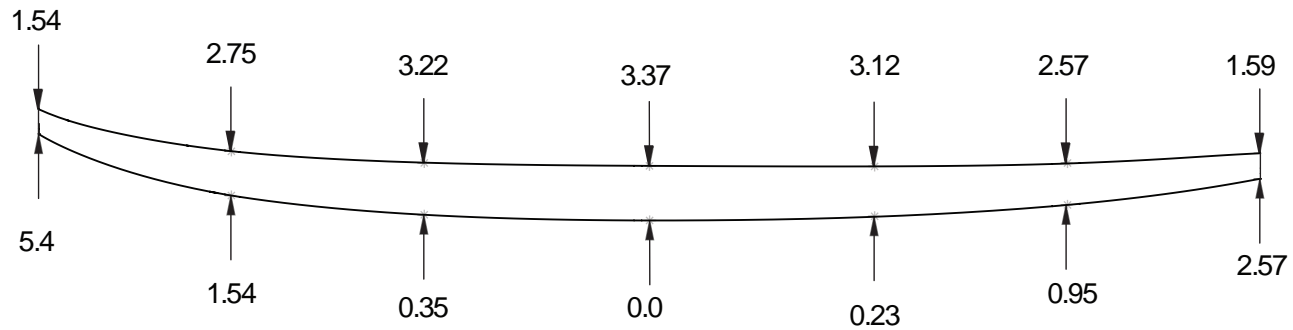
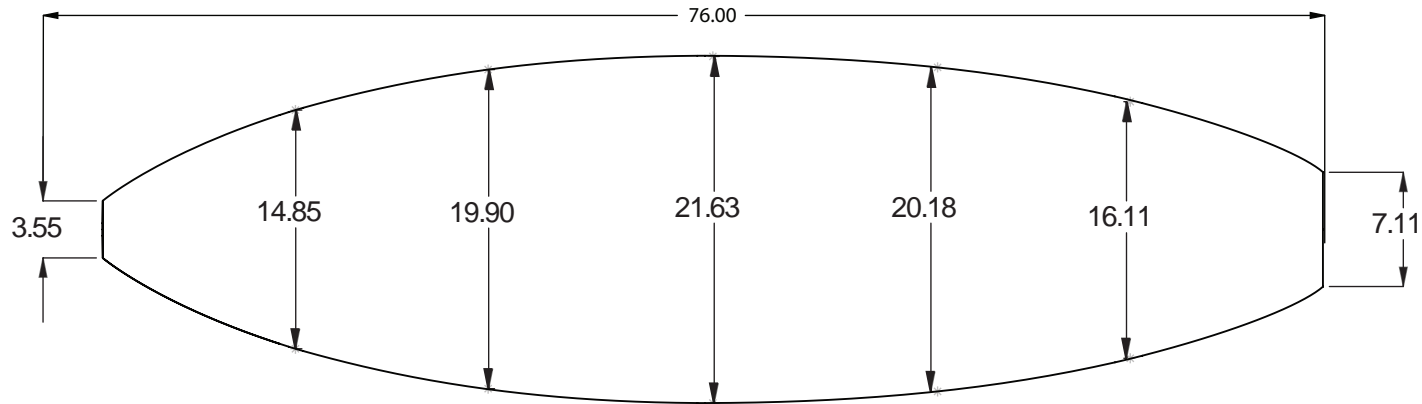

AVAILABLE DENSITIES:

*refer to density chart

STOCK STRINGER:

4mm poplar ply

Updated 5-11-16

SHAPER'S COMMENTS:

This blank is made for hand or machine shaping. Great all purpose "go to" blank.

THIS INFORMATION IN THIS DRAWING IS THE SOLE PROPERTY OF marko foam ANY REPRODUCTION IN PART OR AS A WHOLE WITHOUT THE WRITTEN PERMISSION OF marko foam IS PROHIBITED

100% RECYCLABLE

TITLE:	SHAPER:
6'4" TP THICK	T. PATTERSON

6'6" M

PRESSURE MOLDED EPS BLANKS

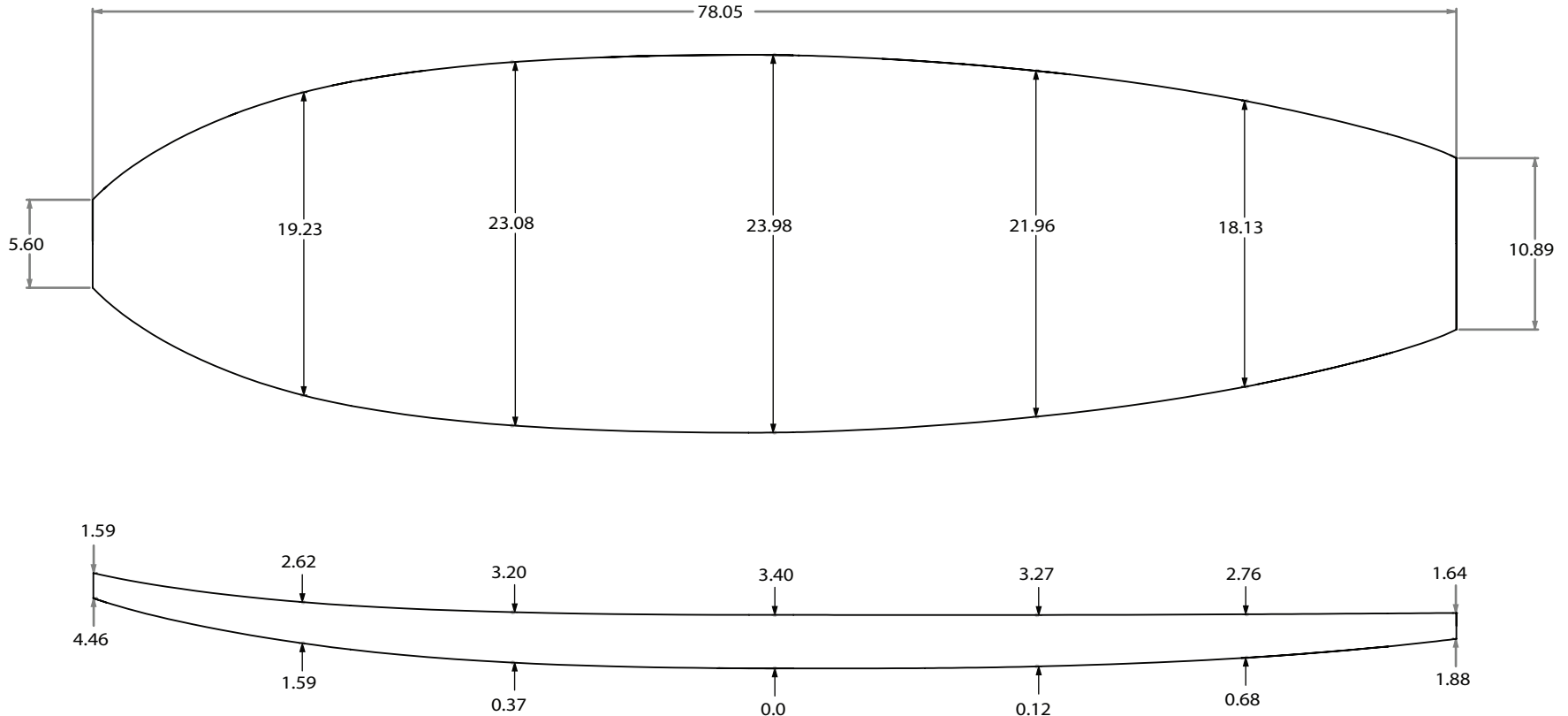

AVAILABLE DENSITIES:

*refer to density chart

STOCK STRINGER:

4mm poplar ply

Updated 5-11-16

SHAPER'S COMMENTS:

"From your cruiser fish to your groveling performance short board the 6'6" m can do it all. This new simplified molded blank, is perfect for almost all boards. The flat wide deck and bottom, square rails, and relaxed rocker caters to a wide variety of boards making it a go to blank for the CNC Machine and Shapers alike. This blank is available stringerless or with our variety of stock stringers."

THIS INFORMATION IN THIS DRAWING IS THE SOLE PROPERTY OF marko foam ANY REPRODUCTION IN PART OR AS A WHOLE WITHOUT THE WRITTEN PERMISSION OF marko foam IS PROHIBITED

100% RECYCLABLE

TITLE:	SHAPER:
6'6 M	Marko Foam

6'6" HALIBUT

PRESSURE MOLDED EPS BLANKS

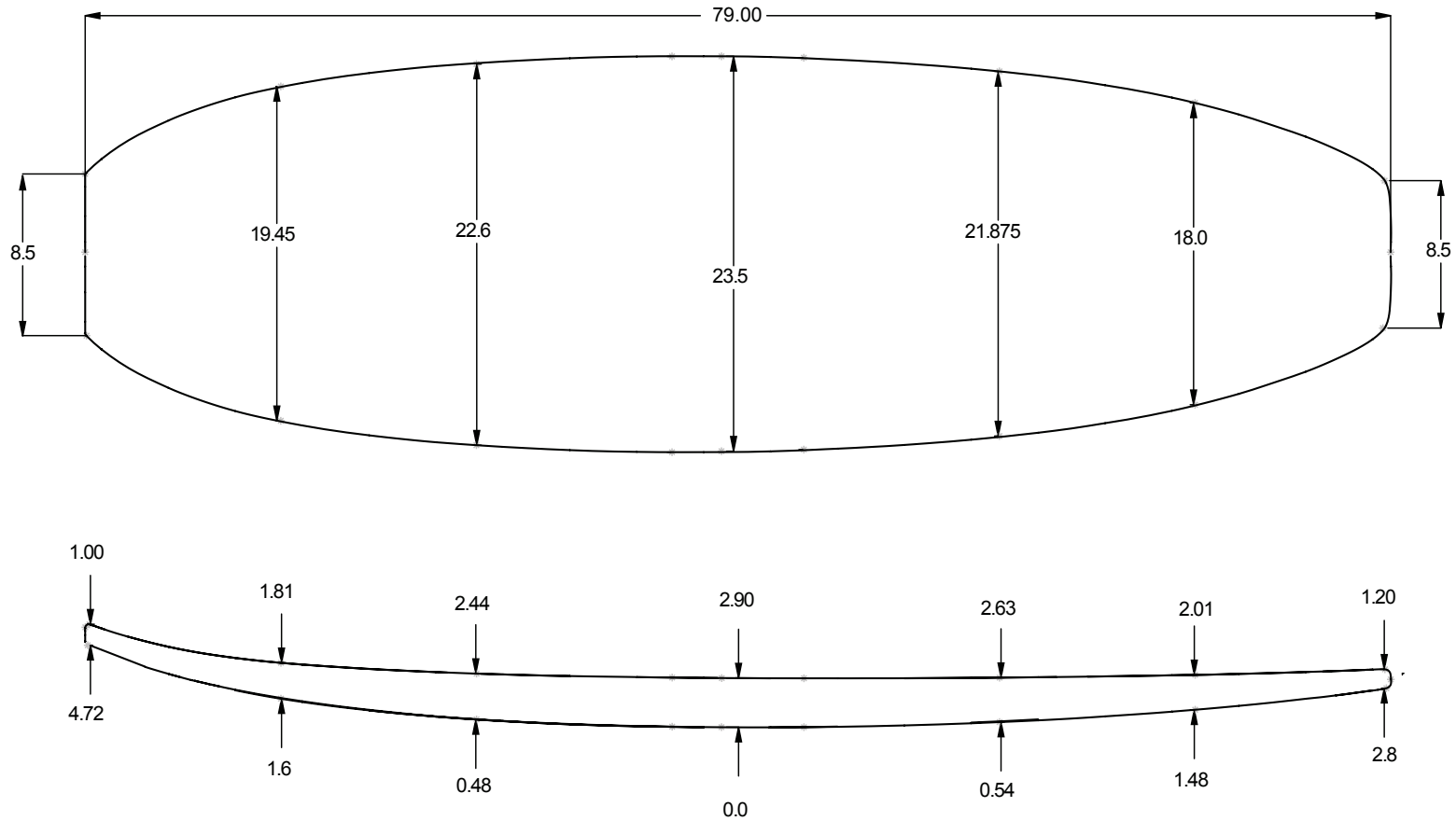

AVAILABLE DENSITIES:

*refer to density chart

STOCK STRINGER:

4mm poplar ply

Not Available in a Stringerless Blank

Updated 5-11-16

This blank is made for hand or machine shaping. The concave in this blank is ideal for modern fish and hybrid shapes.

THIS INFORMATION IN THIS DRAWING IS THE SOLE PROPERTY OF marko foam ANY REPRODUCTION IN PART OR AS A WHOLE WITHOUT THE WRITTEN PERMISSION OF marko foam IS PROHIBITED

100% RECYCLABLE

TITLE:	SHAPER:
6'6" HALIBUT	Marko Foam

6'8" JJ

PRESSURE MOLDED EPS BLANKS

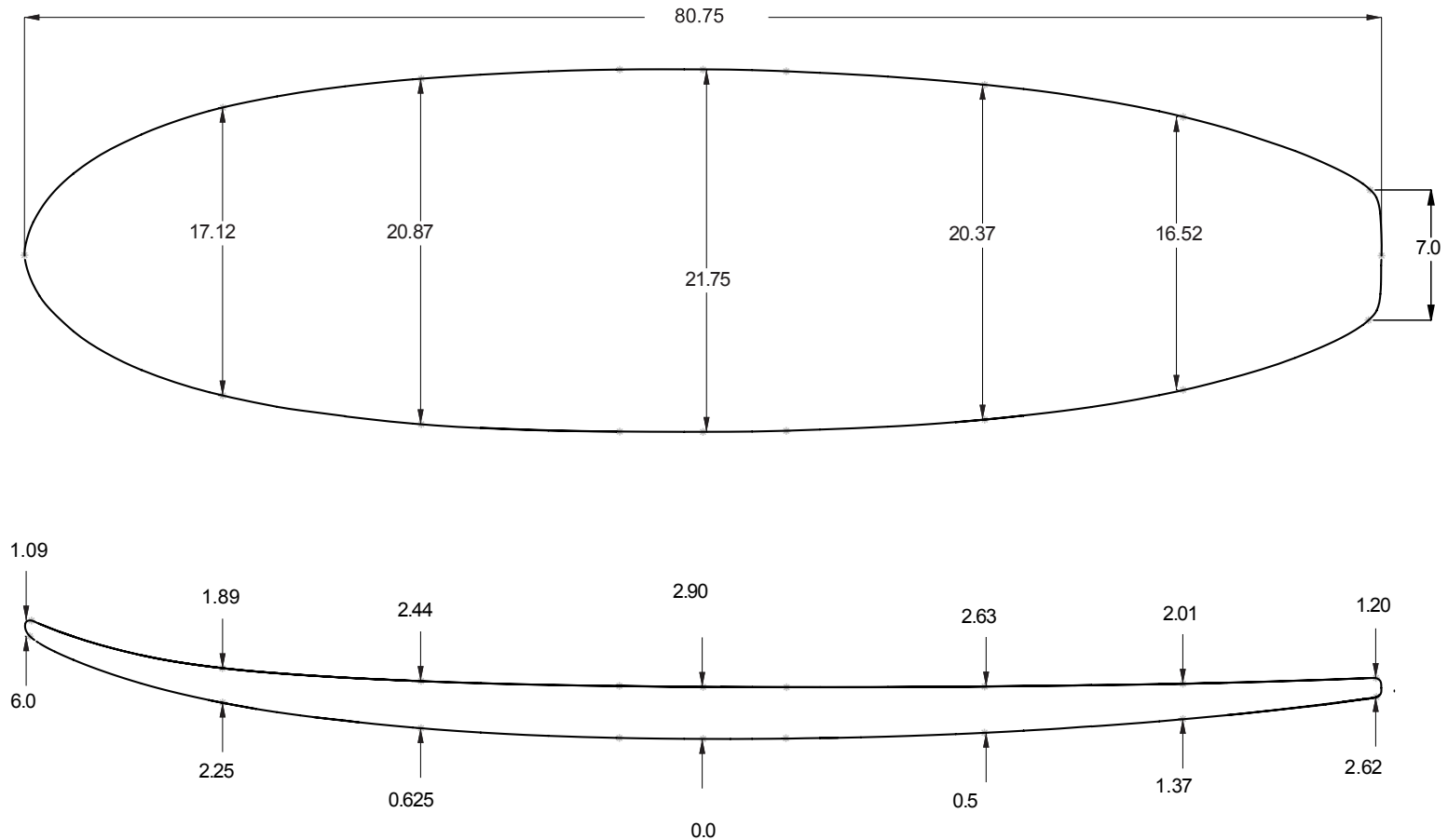

AVAILABLE DENSITIES:

*refer to density chart

STOCK STRINGER:

4mm poplar ply

Updated 5-11-16

SHAPER'S COMMENTS:

All around short board blank made to maximize machine efficiency. This blank has slight concave and the bottom stringer line measures 6'9". Ideal for all kinds of short boards and hybrid shapes.

THIS INFORMATION IN THIS DRAWING IS THE SOLE PROPERTY OF marko foam ANY REPRODUCTION IN PART OR AS A WHOLE WITHOUT THE WRITTEN PERMISSION OF marko foam IS PROHIBITED

100% RECYCLABLE

TITLE:	SHAPER:
6'8" JJ	JEFF JOHNSTON

6'8" THICK

PRESSURE MOLDED EPS BLANKS

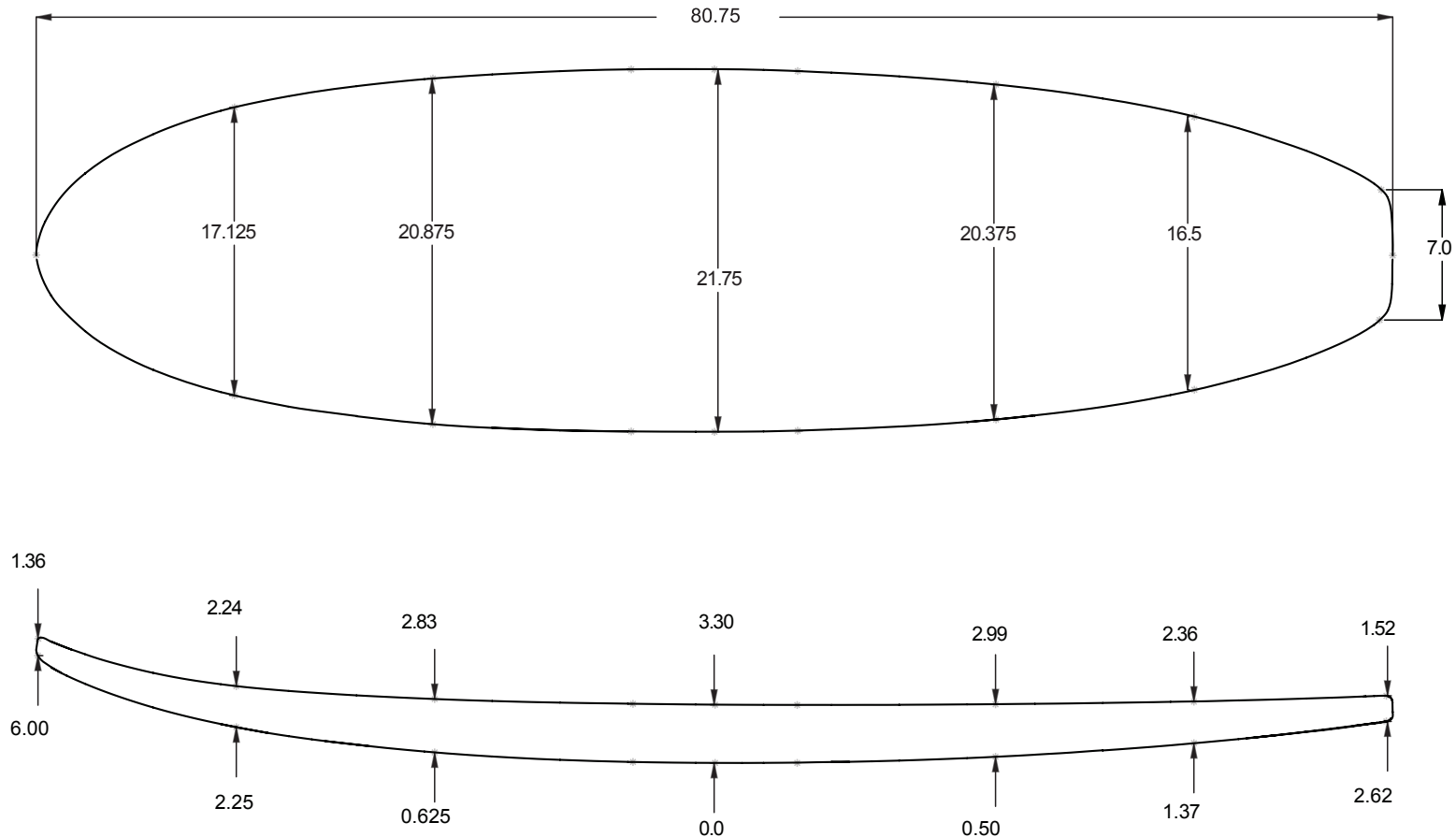

AVAILABLE DENSITIES:

*refer to density chart

STOCK STRINGER:

4mm poplar ply

Updated 5-11-16

SHAPER'S COMMENTS:

This blank is designed for machine shaping. There is about 0.125 concave for maximum cutting ability. Ideal for short boards, big guy boards and fishes. Should be able to cut just about any short board model.

THIS INFORMATION IN THIS DRAWING IS THE SOLE PROPERTY OF marko foam ANY REPRODUCTION IN PART OR AS A WHOLE WITHOUT THE WRITTEN PERMISSION OF marko foam IS PROHIBITED

100% RECYCLABLE

TITLE:

6'8" THICK

SHAPER:

JEFF JOHNSTON

6'8" WHALE

PRESSURE MOLDED EPS BLANKS

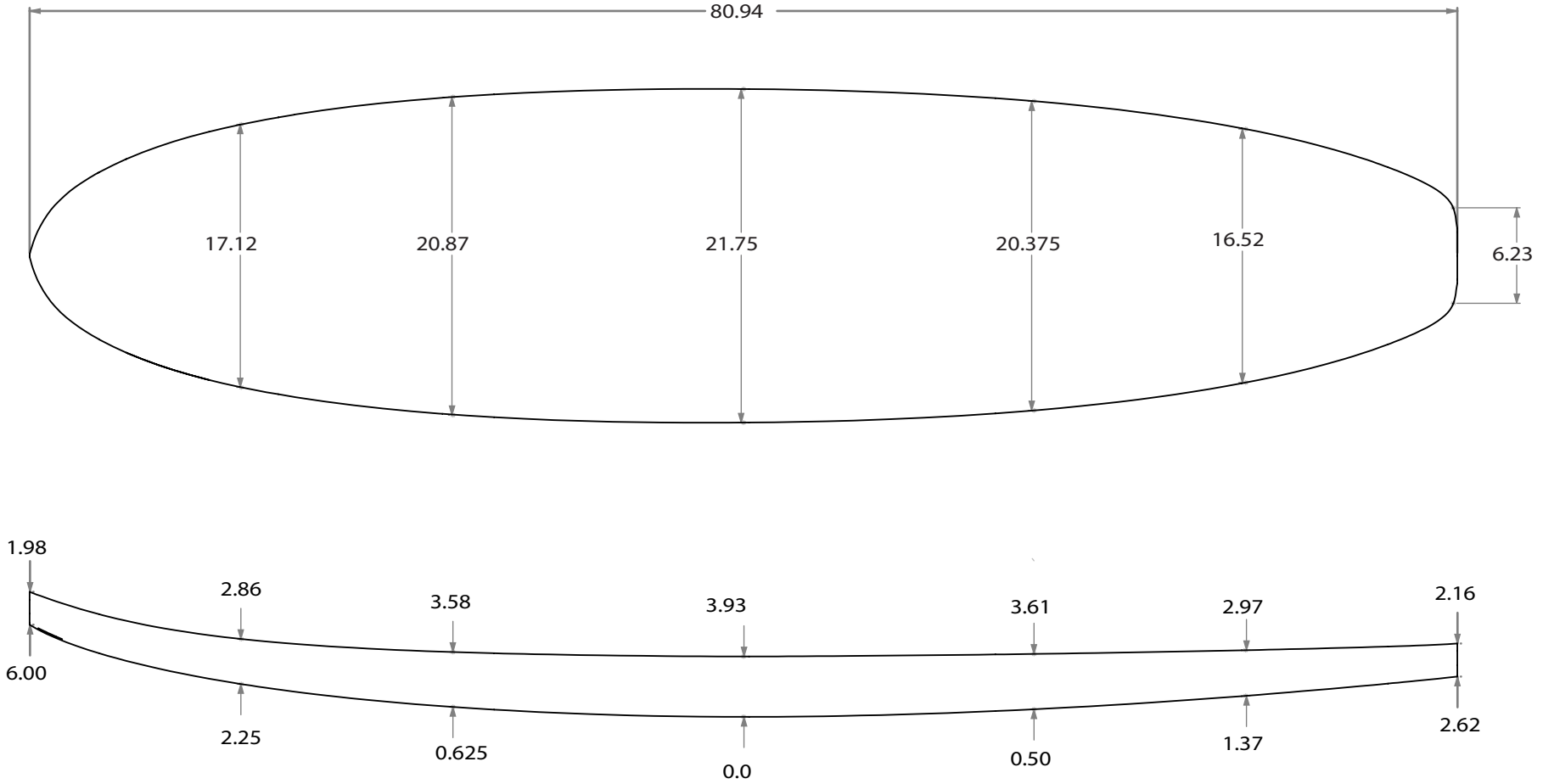

AVAILABLE DENSITIES:

*refer to density chart

STOCK STRINGER:

4mm poplar ply

Updated 5-11-16

SHAPER'S COMMENTS:

This blank brings together everything you need to make a bigger, better and floatier high performance board. With a good amount of nose rocker and plenty of thickness throughout

THIS INFORMATION IN THIS DRAWING IS THE SOLE PROPERTY OF marko foam ANY REPRODUCTION IN PART OR AS A WHOLE WITHOUT THE WRITTEN PERMISSION OF marko foam IS PROHIBITED

100% RECYCLABLE

TITLE:

6'8" Whale

SHAPER:

Marko Foam

7'2" M REGULAR

PRESSURE MOLDED EPS BLANKS

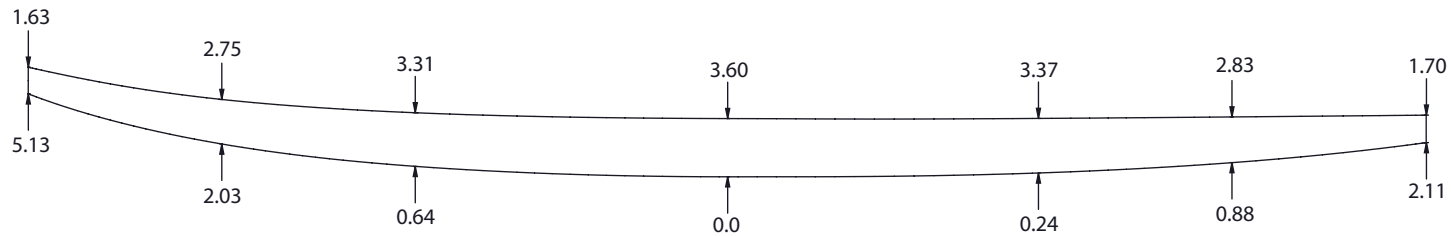
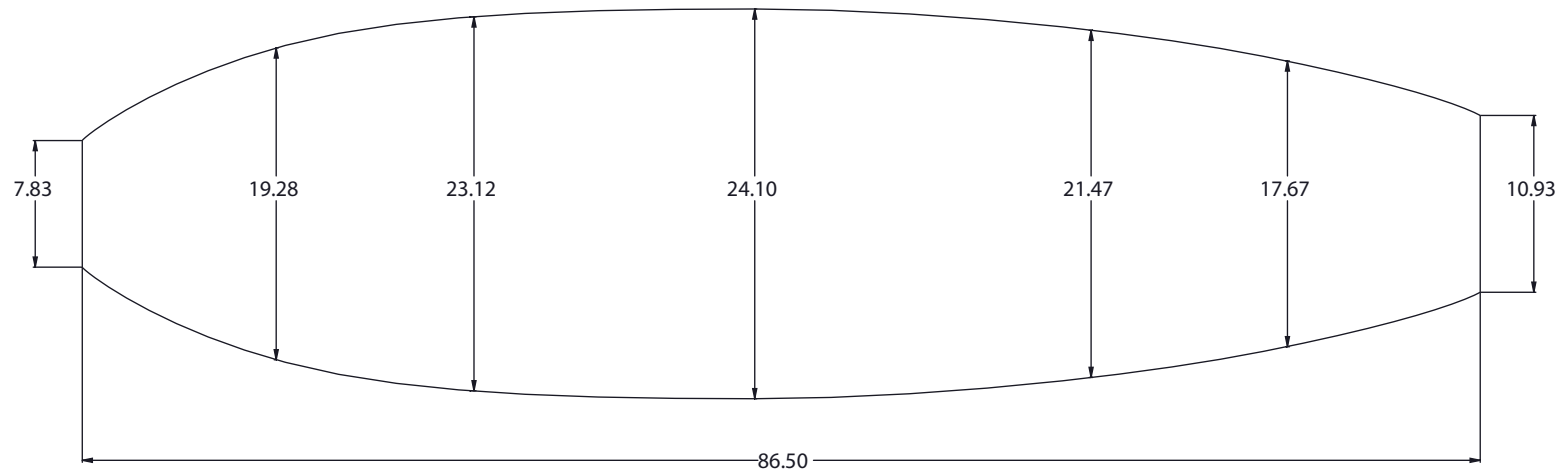

AVAILABLE DENSITIES:

*refer to density chart

STOCK STRINGER:

4mm poplar ply

Updated 5-11-16

SHAPER'S COMMENTS:

The 7'2" M Regular can do it all. The new simplified molded blank is perfect for almost all boards. The wide deck and bottom, square rails and relaxed rocker caters to a wide variety of boards making it a go to blank for CNC machines and hand shapers alike. This blank is available stringer-less.

THIS INFORMATION IN THIS DRAWING IS THE SOLE PROPERTY OF marko foam ANY REPRODUCTION IN PART OR AS A WHOLE WITHOUT THE WRITTEN PERMISSION OF marko foam IS PROHIBITED

100% RECYCLABLE

TITLE:

7'2" M Regular

SHAPER:

Marko Foam

7'2" M THICK

PRESSURE MOLDED EPS BLANKS

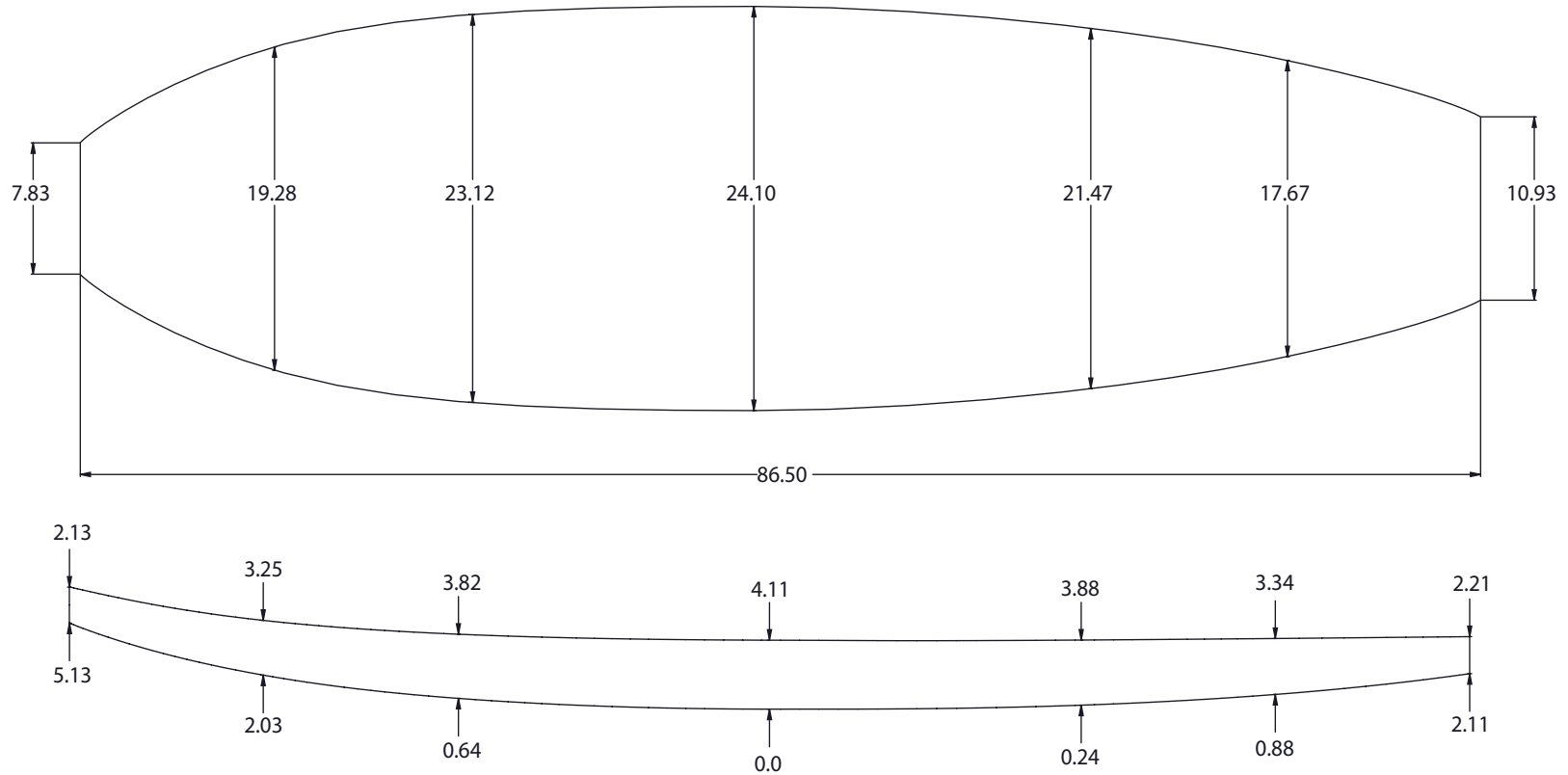

AVAILABLE DENSITIES:
*refer to density chart

STOCK STRINGER:
4mm poplar ply

Updated 5-11-16

SHAPER'S COMMENTS:

The 7'2" M Thick can do it all. The new simplified molded blank is perfect for almost all boards. The wide deck and bottom, square rails and relaxed rocker caters to a wide variety of boards making it a go to blank for CNC machines and hand shapers alike. This blank is available stringer-less.

THIS INFORMATION IN THIS DRAWING IS THE SOLE PROPERTY OF marko foam ANY REPRODUCTION IN PART OR AS A WHOLE WITHOUT THE WRITTEN PERMISSION OF marko foam IS PROHIBITED

100% RECYCLABLE

TITLE:

7'2" M Thick

SHAPER:

Marko Foam

7'4" HALIBUT

PRESSURE MOLDED EPS BLANKS

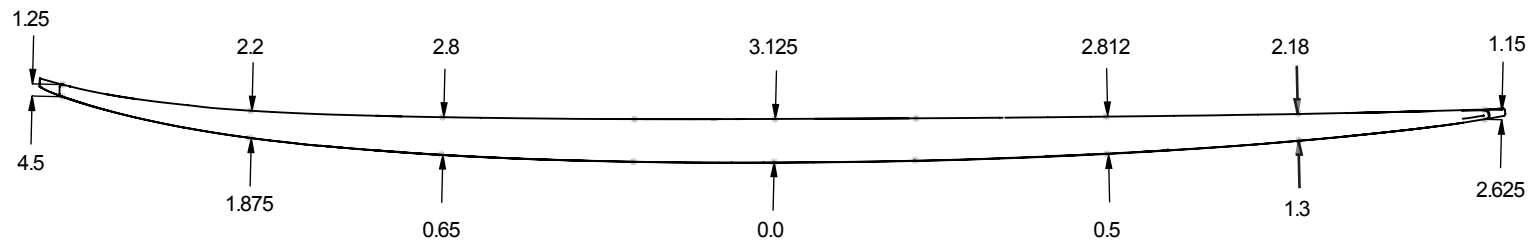
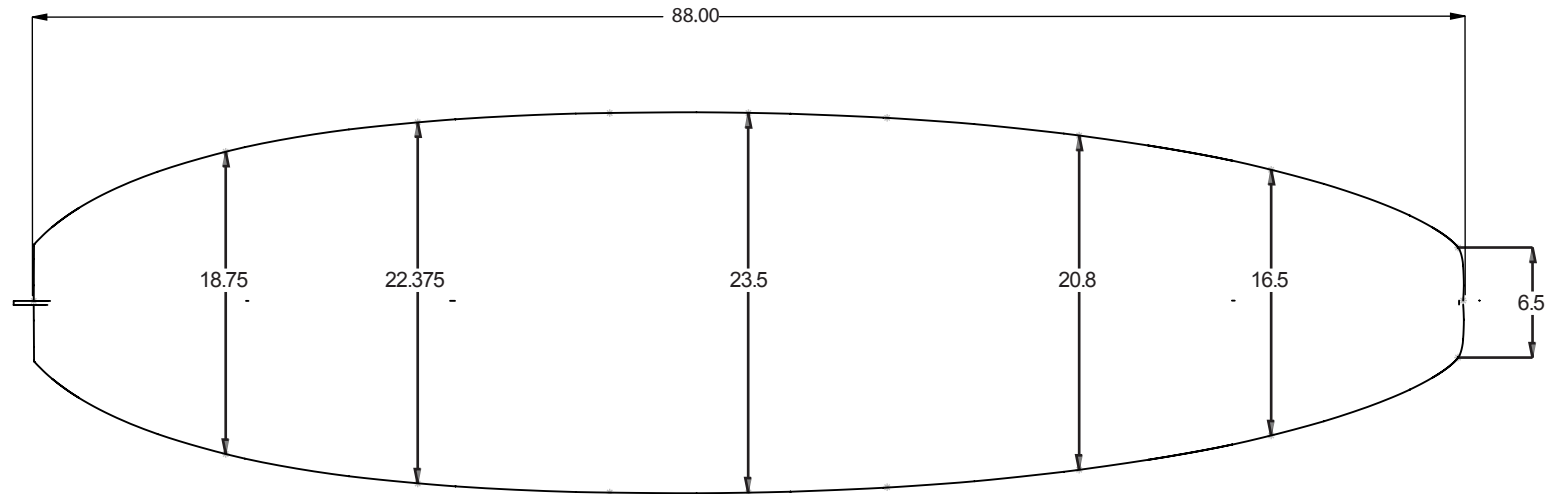

AVAILABLE DENSITIES:

*refer to density chart

STOCK STRINGER:

4mm poplar ply

Not Available in a Stringerless Blank

Updated 5-11-16

SHAPER'S COMMENTS:

Big guy fish blank with plenty of deckroll for hand shaping or machine cuts. This blank should be able to fit most any mid size fish or big guy models.

THIS INFORMATION IN THIS DRAWING IS THE SOLE PROPERTY OF marko foam ANY REPRODUCTION IN PART OR AS A WHOLE WITHOUT THE WRITTEN PERMISSION OF marko foam IS PROHIBITED

100% RECYCLABLE

TITLE:

7'4" HALIBUT

SHAPER:

Marko Foam

7'5" MACHINE ALL

PRESSURE MOLDED EPS BLANKS

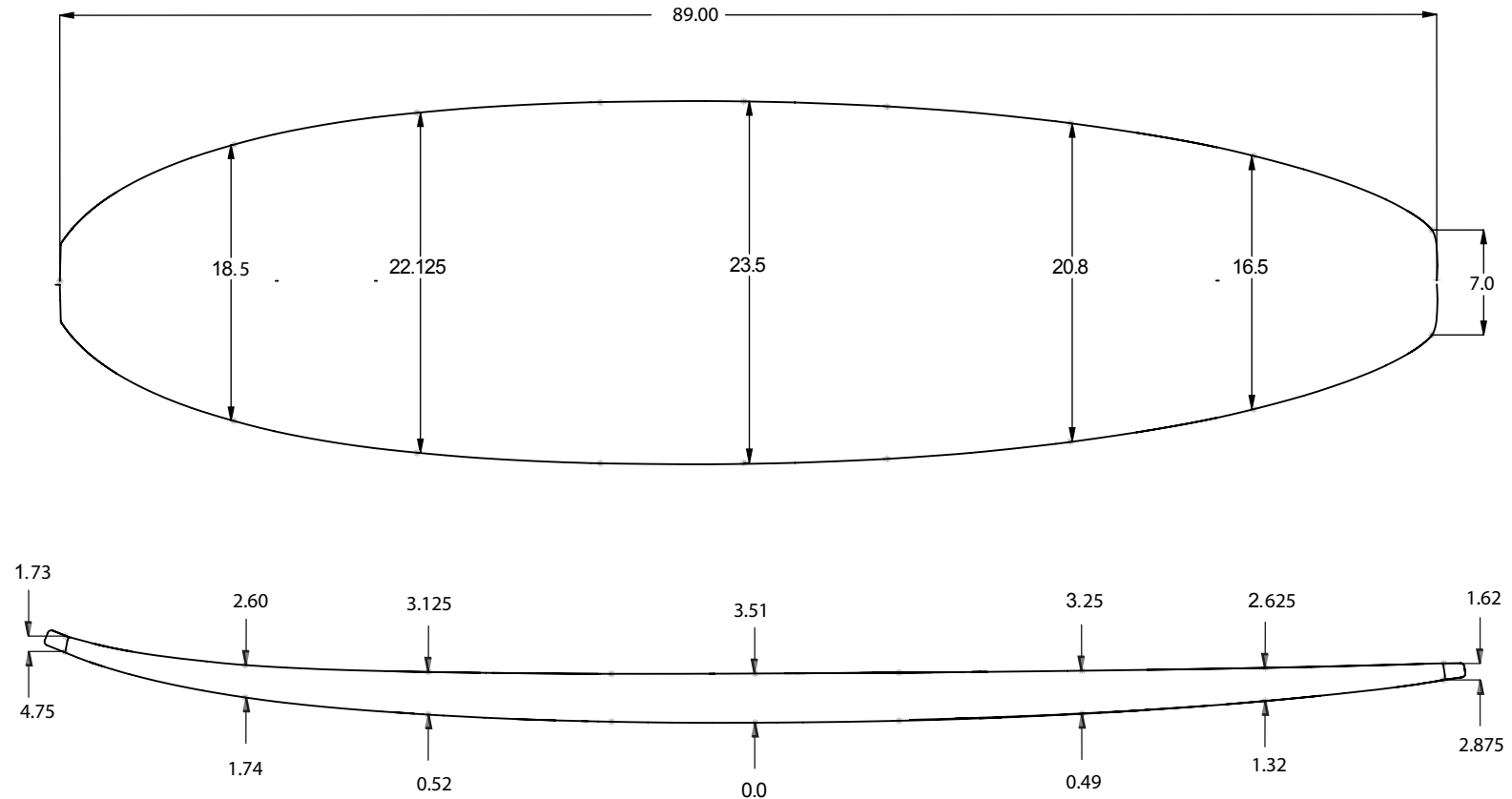

AVAILABLE DENSITIES:

*refer to density chart

STOCK STRINGER:

4mm poplar ply

Not Available in Stringerless Blank

Updated 5-11-16

SHAPER'S COMMENTS:

This blank is designed for machine shaping and capturing the Big Guy hybrid shapes. The natural rocker achieves most all needs, and can be altered to your specs.

THIS INFORMATION IN THIS DRAWING IS THE SOLE PROPERTY OF marko foam ANY REPRODUCTION IN PART OR AS A WHOLE WITHOUT THE WRITTEN PERMISSION OF marko foam IS PROHIBITED

100% RECYCLABLE

TITLE:

7'5" MACHINE ALL

SHAPER:

Marko Foam

7'6" THICK

PRESSURE MOLDED EPS BLANKS

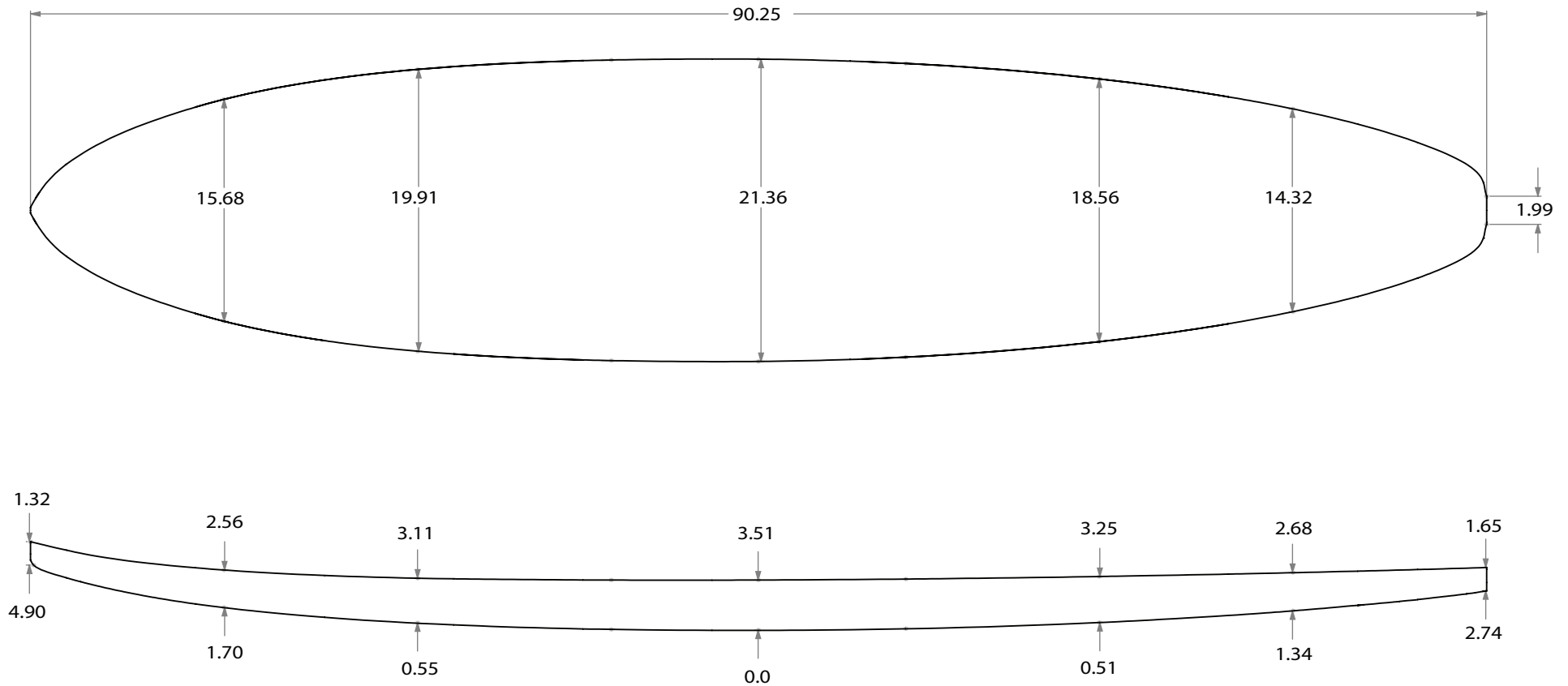

AVAILABLE DENSITIES:

*refer to density chart

STOCK STRINGER:

4mm poplar ply

Updated 5-11-16

SHAPER'S COMMENTS:

This blank is very similar to the 7'6" JJ with the fun board rocker making it perfect your bigger shortboards and big hybrid shapes. It has added thickness making it perfect machine shaping and giving you a volume to work with.

THIS INFORMATION IN THIS DRAWING IS THE SOLE PROPERTY OF marko foam ANY REPRODUCTION IN PART OR AS A WHOLE WITHOUT THE WRITTEN PERMISSION OF marko foam IS PROHIBITED

100% RECYCLABLE

TITLE:

7'6" Thick

SHAPER:

JEFF JOHNSTON

7'6" JJ

PRESSURE MOLDED EPS BLANKS

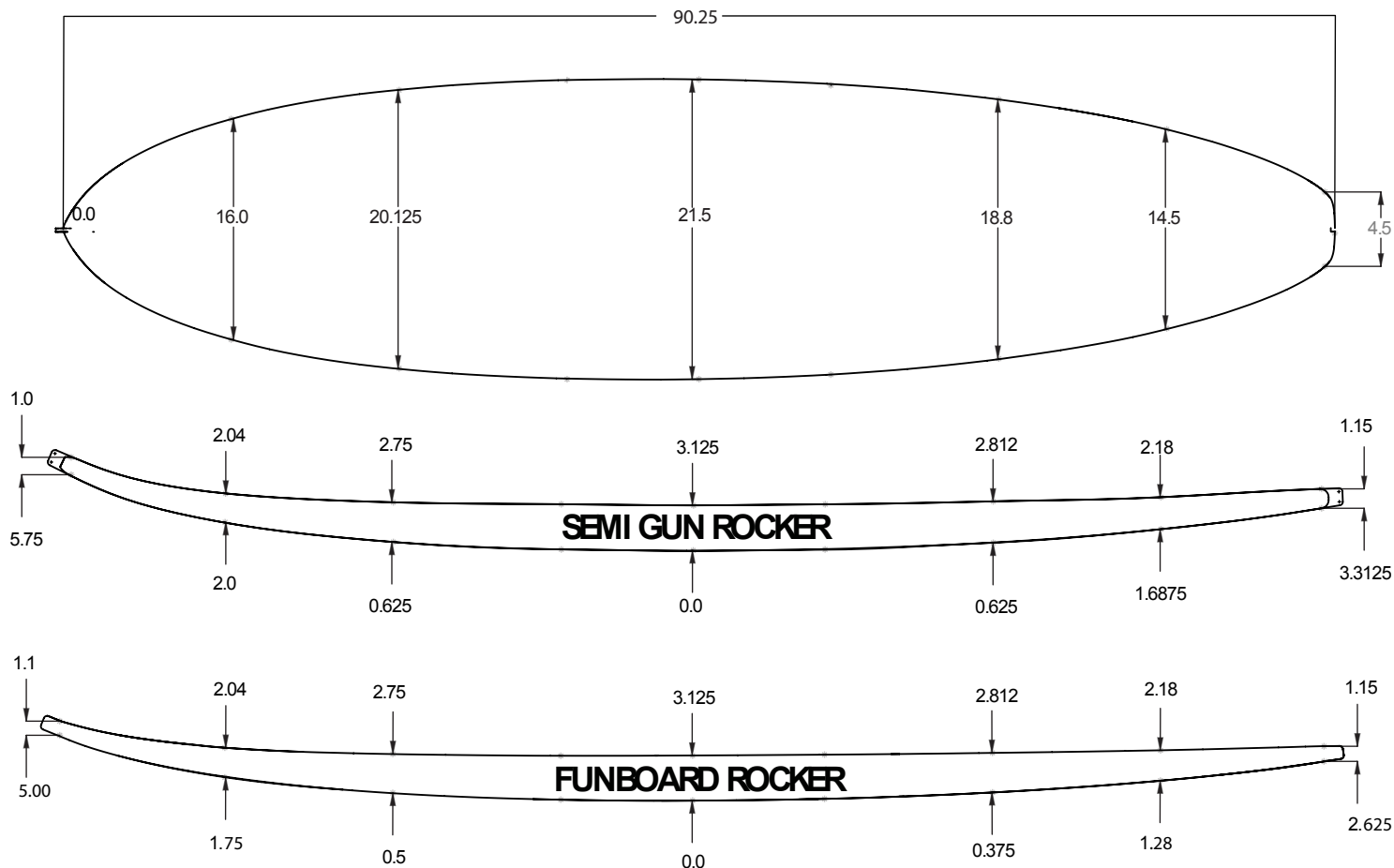

AVAILABLE DENSITIES:

*refer to density chart

STOCK STRINGER:

4mm poplar ply

Updated 5-11-16

SHAPER'S COMMENTS:

The ideal blank for larger short boards, mini guns and big hybrid shapes that need more rocker. Good for hand shaping and plenty of thickness throughout for machine cuts. Available in fun board and Semigun rocker.

THIS INFORMATION IN THIS DRAWING IS THE SOLE PROPERTY OF marko foam ANY REPRODUCTION IN PART OR AS A WHOLE WITHOUT THE WRITTEN PERMISSION OF marko foam IS PROHIBITED

100% RECYCLABLE

TITLE:	SHAPER:
7'6" JJ	JEFF JOHNSTON

7'6" JJ FINISH SHAPE

PRESSURE MOLDED EPS BLANKS

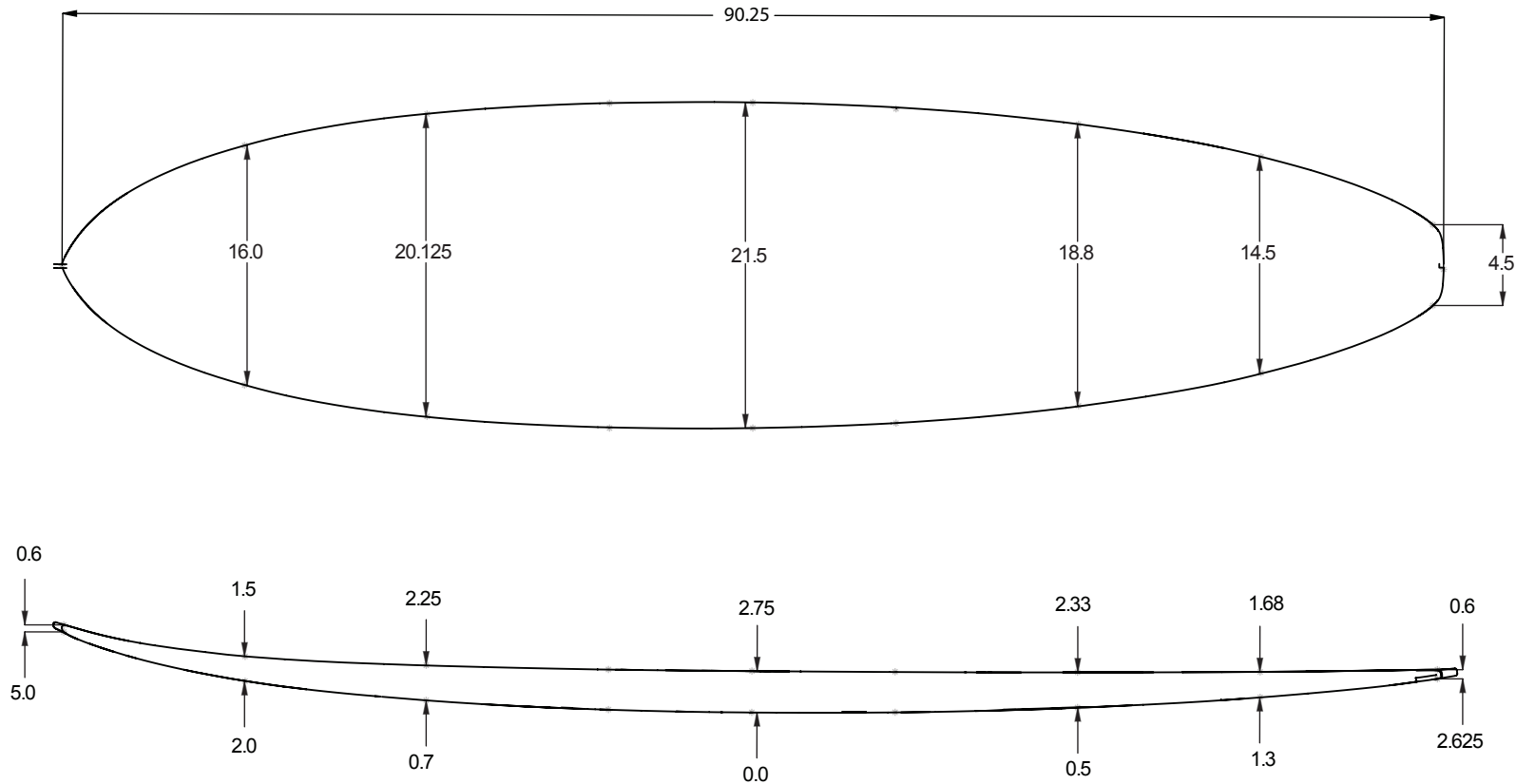

AVAILABLE DENSITIES:

*refer to density chart

STOCK STRINGER:

4mm poplar ply

Updated 5-11-16

SHAPER'S COMMENTS:

This is a close tolerance 90% finished shape blank. Designed to be finish sanded straight from the mold. Great for kits and beginning shapers.

THIS INFORMATION IN THIS DRAWING IS THE SOLE PROPERTY OF marko foam ANY REPRODUCTION IN PART OR AS A WHOLE WITHOUT THE WRITTEN PERMISSION OF marko foam IS PROHIBITED

100% RECYCLABLE

TITLE:	SHAPER:
7'6" JJ FS	JEFF JOHNSTON

8'5" UNIVERSAL

PRESSURE MOLDED EPS BLANKS

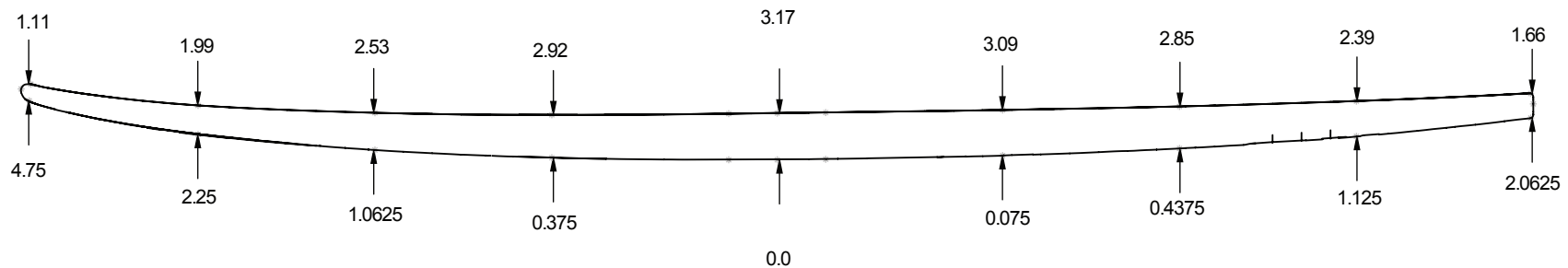
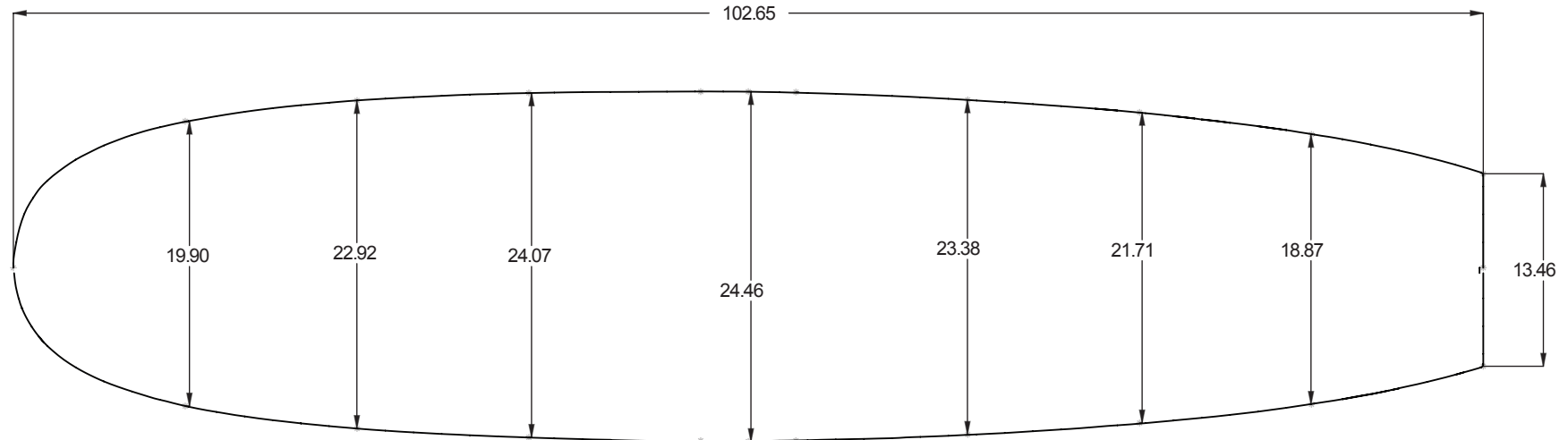

AVAILABLE DENSITIES:

*refer to density chart

STOCK STRINGER:

1/8" Bass

Updated 5-11-16

SHAPER'S COMMENTS:

A very well balanced blank for hand shaping with room to move for cutting on the machine. Blank is shaped with a slight concave to maximize board design and thickness.

THIS INFORMATION IN THIS DRAWING IS THE SOLE PROPERTY OF marko foam ANY REPRODUCTION IN PART OR AS A WHOLE WITHOUT THE WRITTEN PERMISSION OF marko foam IS PROHIBITED

100% RECYCLABLE

TITLE:	SHAPER:
8'5" UNIVERSAL	Marko Foam

8'5" THICK

PRESSURE MOLDED EPS BLANKS

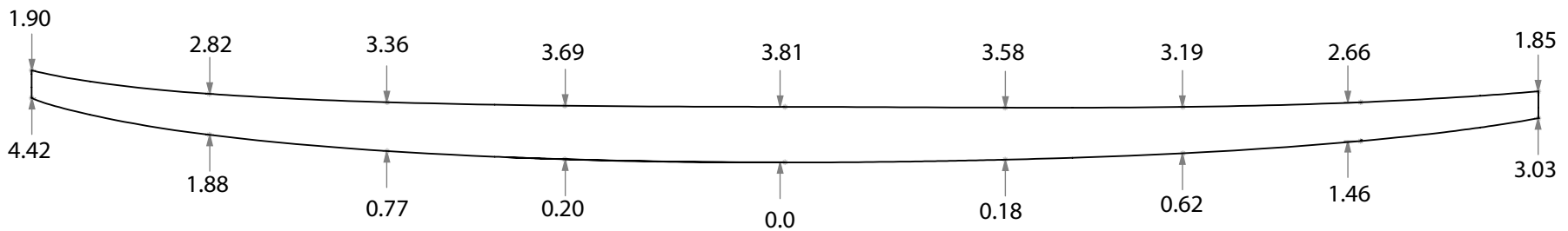
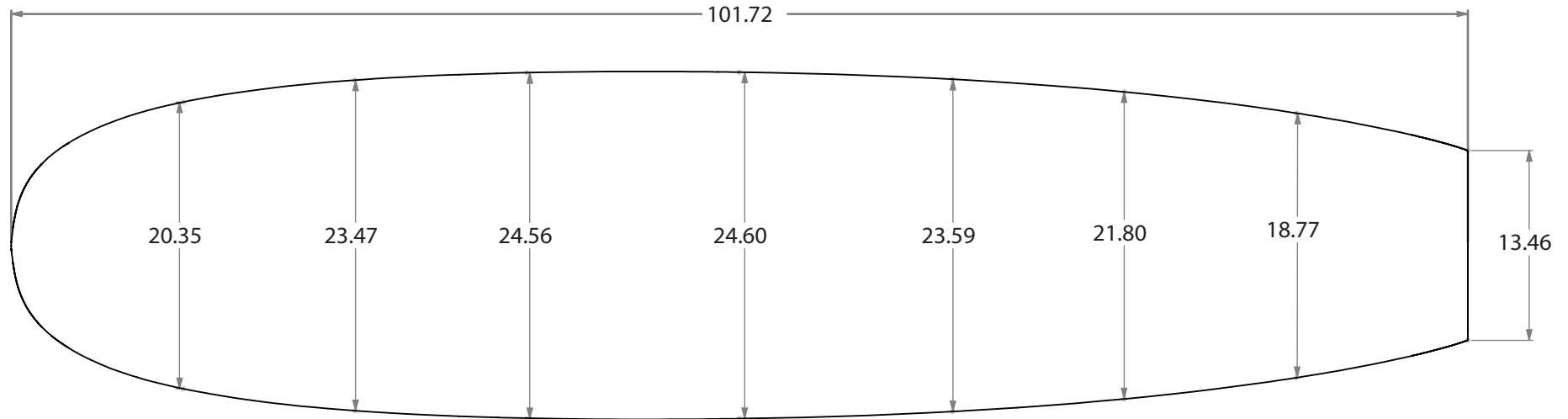

AVAILABLE DENSITIES:

*refer to density chart

STOCK STRINGER:

1/8" Bass

Updated 5-11-16

SHAPER'S COMMENTS:

From a big fish to a longboard and everything in between, this blank can do it all. With added thickness from the 8'5" universal this blank can fit almost any board and is perfect for machine shaping.

THIS INFORMATION IN THIS DRAWING IS THE SOLE PROPERTY OF marko foam ANY REPRODUCTION IN PART OR AS A WHOLE WITHOUT THE WRITTEN PERMISSION OF marko foam IS PROHIBITED

100% RECYCLABLE

TITLE:

8'5" Thick

SHAPER:

Marko Foam

9'1" JJ HYPER - FORM

PRESSURE MOLDED EPS BLANKS

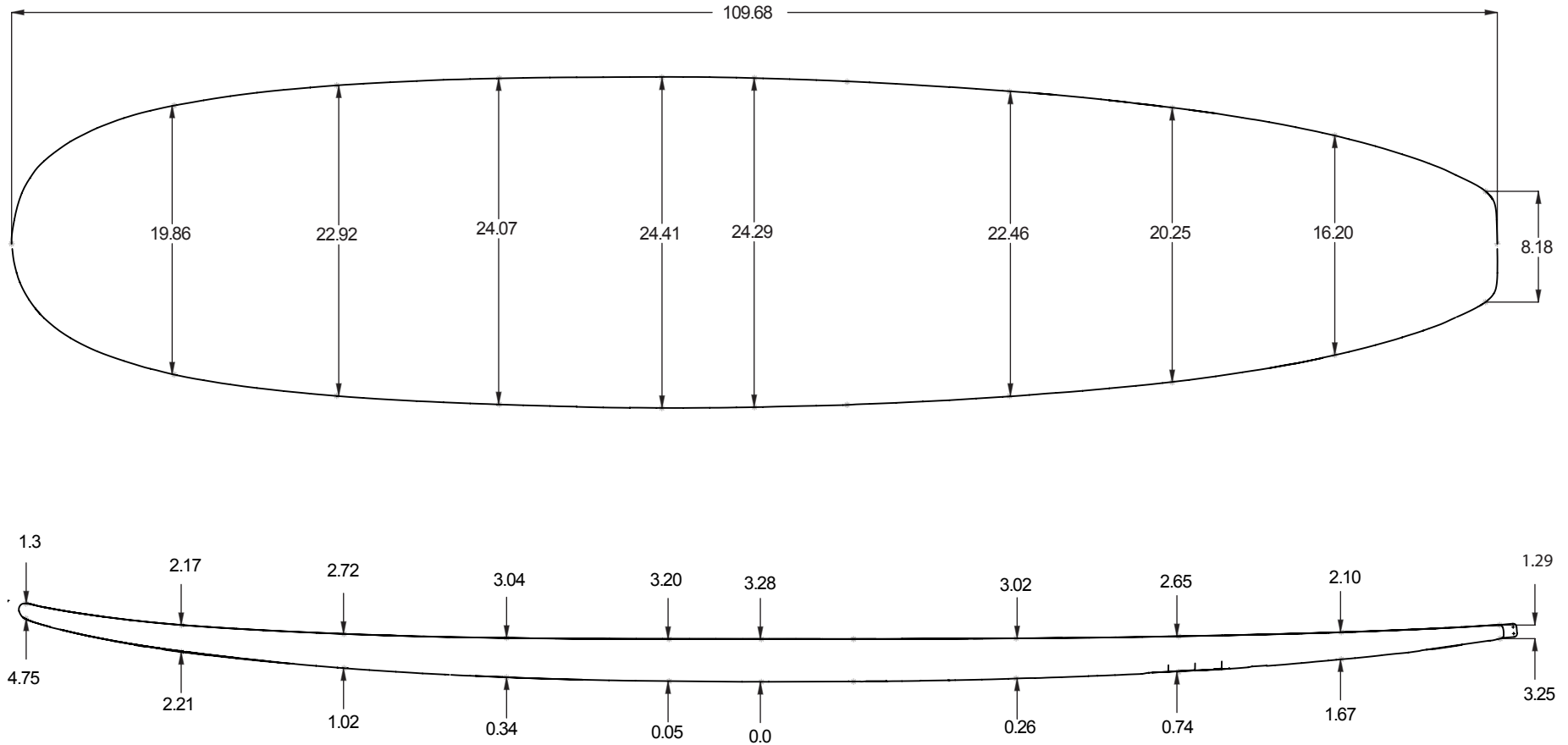

AVAILABLE DENSITIES:

*refer to density chart

STOCK STRINGER:

1/8" Bass

Updated 5-11-16

SHAPER'S COMMENTS:

A very well balanced blank for hand shaping with room to move for cutting on the machine. Blank is shaped with a slight concave to maximize board design and thickness.

THIS INFORMATION IN THIS DRAWING IS THE SOLE PROPERTY OF marko foam ANY REPRODUCTION IN PART OR AS A WHOLE WITHOUT THE WRITTEN PERMISSION OF marko foam IS PROHIBITED

100% RECYCLABLE

TITLE:	SHAPER:
9'1" JJ HYPER-FORM	JEFF JOHNSTON

9'1" MACHINE ALL

PRESSURE MOLDED EPS BLANKS

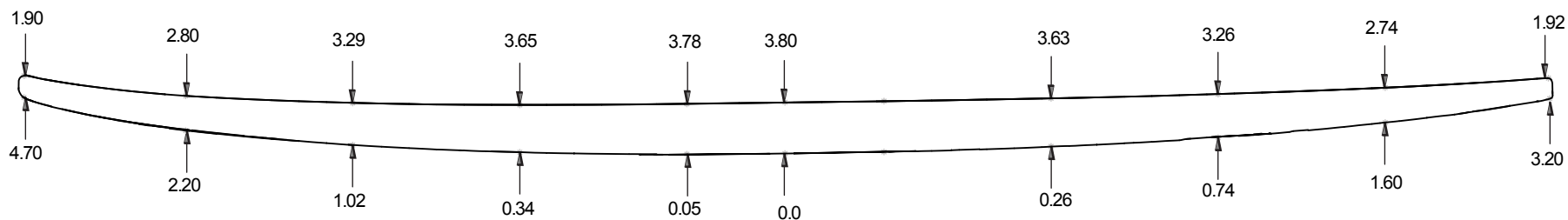
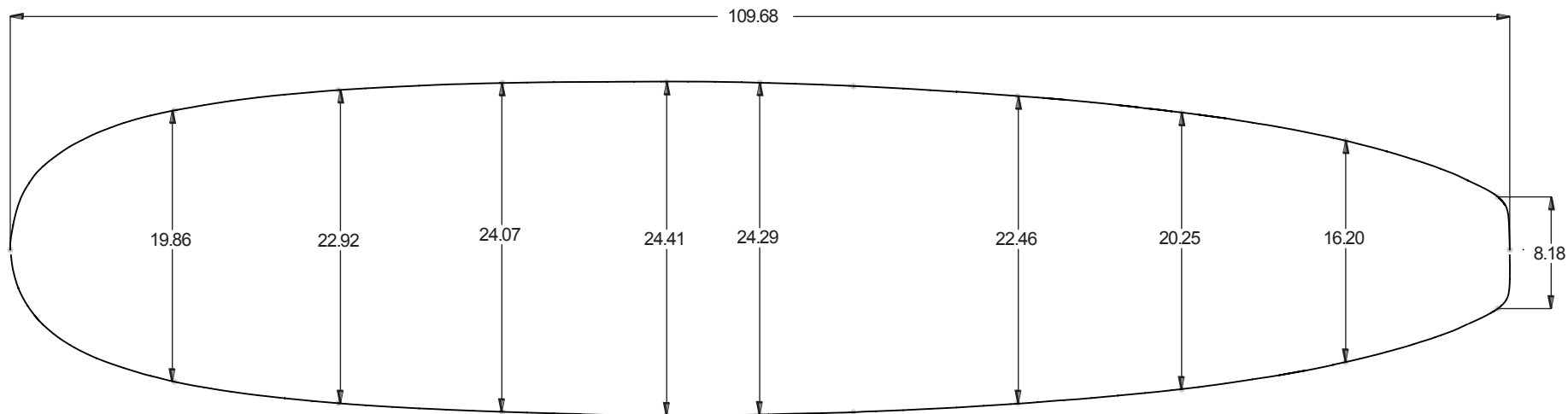

AVAILABLE DENSITIES:

*refer to density chart

STOCK STRINGER:

1/8" Bass

Updated 5-11-16

SHAPER'S COMMENTS:

This blank is designed for machine shaping and capturing most all big guy hybrid and performance long boards. Natural rocker can be altered to meet your needs.

THIS INFORMATION IN THIS DRAWING IS THE SOLE PROPERTY OF marko foam ANY REPRODUCTION IN PART OR AS A WHOLE WITHOUT THE WRITTEN PERMISSION OF marko foam IS PROHIBITED

100% RECYCLABLE

TITLE:	SHAPER:
9'1" MACHINE ALL	Marko Foam

9'6" HB CLASSIC

BLOCK CUT EPS

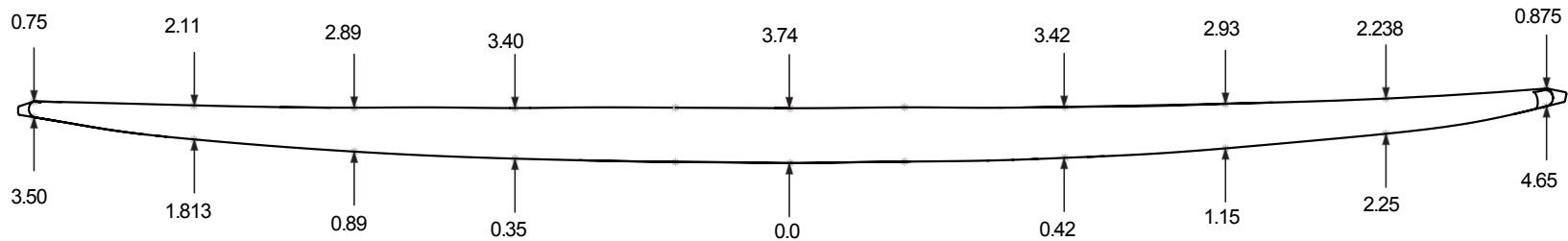
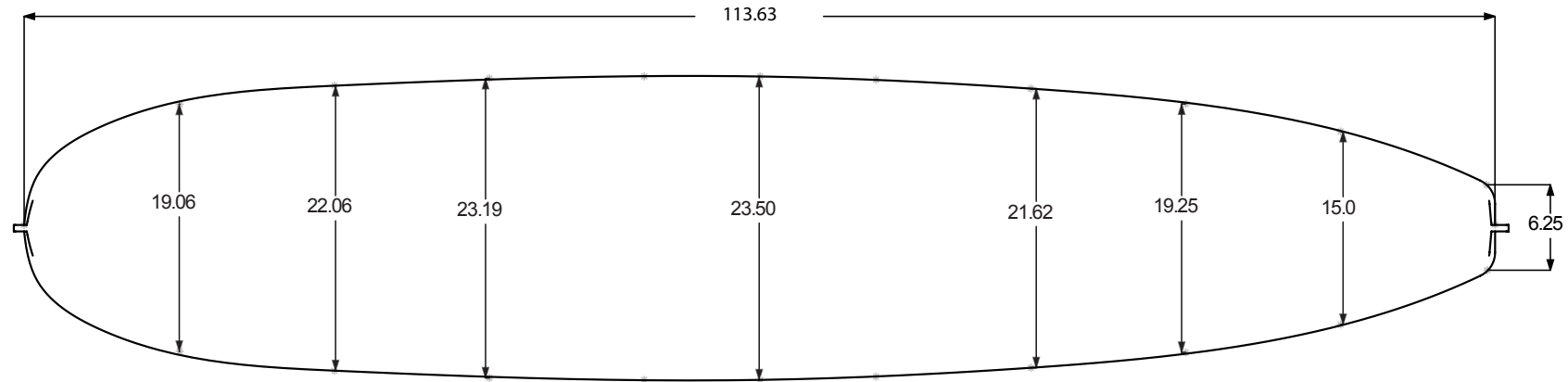

AVAILABLE DENSITIES:

*refer to density chart

STOCK STRINGER:

1/8" Bass

Updated 5-11-16

SHAPER'S COMMENTS:

This 9'6" classic long board style blank was created by long time shaper Hank Byzak and dedicated EPS proponent Dan Hirsch. Their approach was to create a tight tolerance shaping blank and a functional big guy board that would be close to finish right out of the pressure molding process with very little fine tuning left to complete the shape.

THIS INFORMATION IN THIS DRAWING IS THE SOLE PROPERTY OF marko foam ANY REPRODUCTION IN PART OR AS A WHOLE WITHOUT THE WRITTEN PERMISSION OF marko foam IS PROHIBITED

100% RECYCLABLE

TITLE:	SHAPER:
9'6" HB CLASSIC	HANK BYZACK R&D - DAN HIRSCH

MK-7'0"

BLOCK CUT EPS

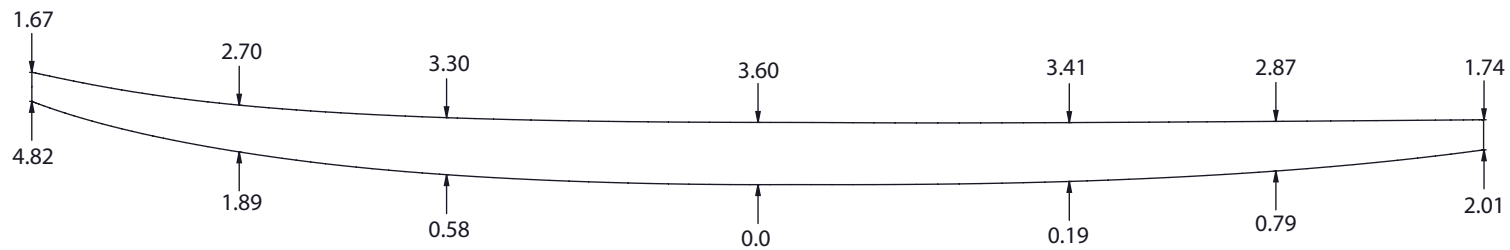
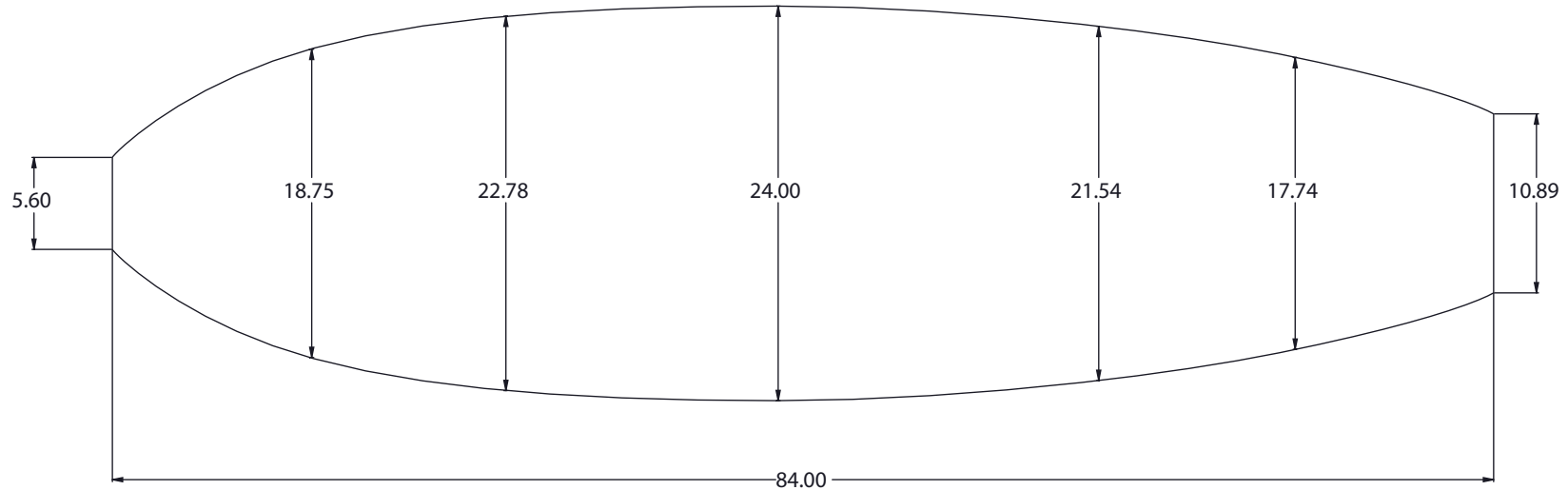

AVAILABLE DENSITIES:
refer to density chart
STOCK STRINGER:
4mm poplar ply

Updated 5-11-16

SHAPER'S COMMENTS:
A blank made perfectly for a big boy or fun board with a mellow rocker profile and wide deck. This blank is cut out of block EPS on a computer controlled hotwire machine to ensure the same blank dimensions everytime.

THIS INFORMATION IN THIS DRAWING IS THE SOLE PROPERTY OF marko foam ANY REPRODUCTION IN PART OR AS A WHOLE WITHOUT THE WRITTEN PERMISSION OF marko foam IS PROHIBITED

100% RECYCLABLE

TITLE:
MK- 7'0"

SHAPER:
Marko Foam

MK-9'6"

BLOCK CUT EPS

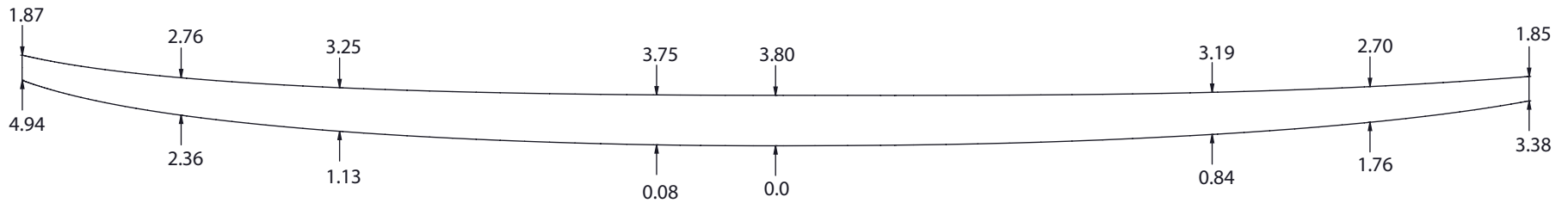
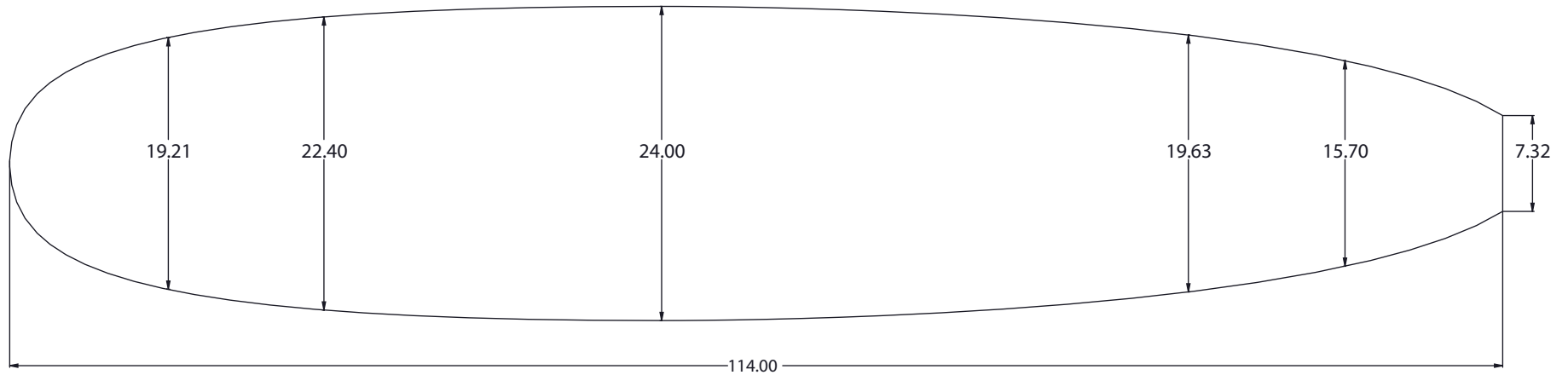

AVAILABLE DENSITIES:

*refer to density chart

STOCK STRINGER:

1/8" Bass

Updated 5-11-16

SHAPER'S COMMENTS:

A blank made perfectly for your next longboard. With plenty of width and thickness it is perfect for a mellow cruiser or a high performance log. This blank is cut out of block EPS on a computer controlled hotwire machine to ensure the same blank dimensions everytime.

THIS INFORMATION IN THIS DRAWING IS THE SOLE PROPERTY OF marko foam ANY REPRODUCTION IN PART OR AS A WHOLE WITHOUT THE WRITTEN PERMISSION OF marko foam IS PROHIBITED

100% RECYCLABLE

TITLE:

MK-9'6"

SHAPER:

Marko Foam

MK- 10'6"

BLOCK CUT EPS

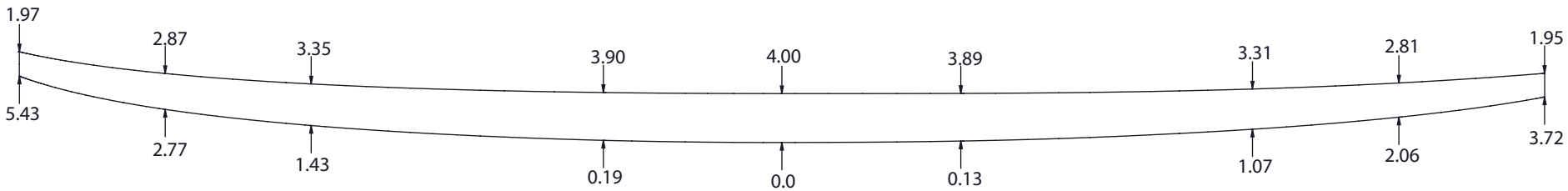
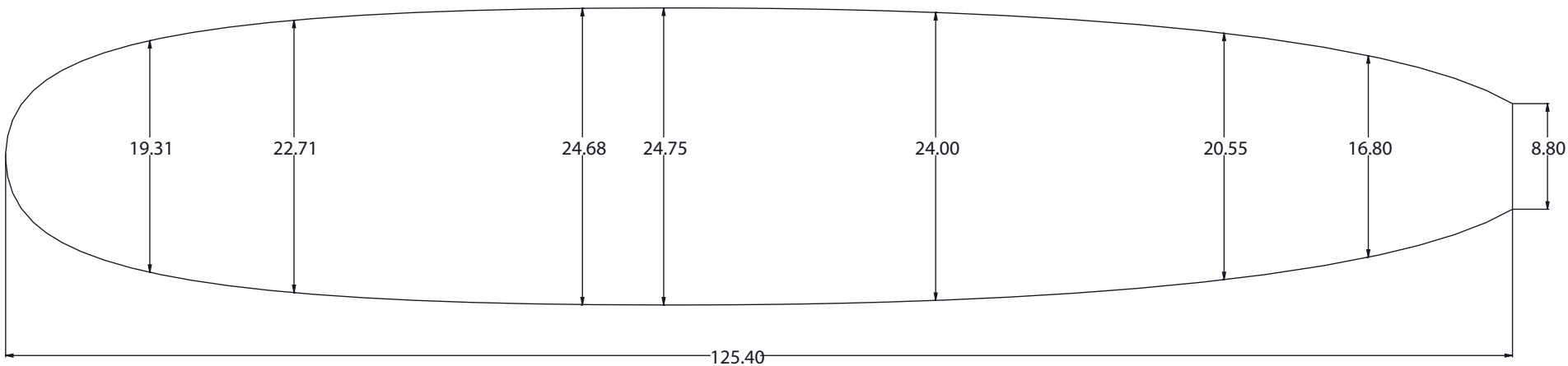

AVAILABLE DENSITIES:

*refer to density chart

STOCK STRINGER:

1/8" Bass

Updated 5-11-16

SHAPER'S COMMENTS:

A blank made perfectly for your next longboard. With plenty of width and thickness it is perfect for a mellow cruiser or a high performance log. This blank is cut out of block EPS on a computer controlled hotwire machine to ensure the same blank dimensions everytime.

THIS INFORMATION IN THIS DRAWING IS THE SOLE PROPERTY OF marko foam ANY REPRODUCTION IN PART OR AS A WHOLE WITHOUT THE WRITTEN PERMISSION OF marko foam IS PROHIBITED

100% RECYCLABLE

TITLE:

MK- 10'6"

SHAPER:

Marko Foam

MK- 10'10"

BLOCK CUT EPS

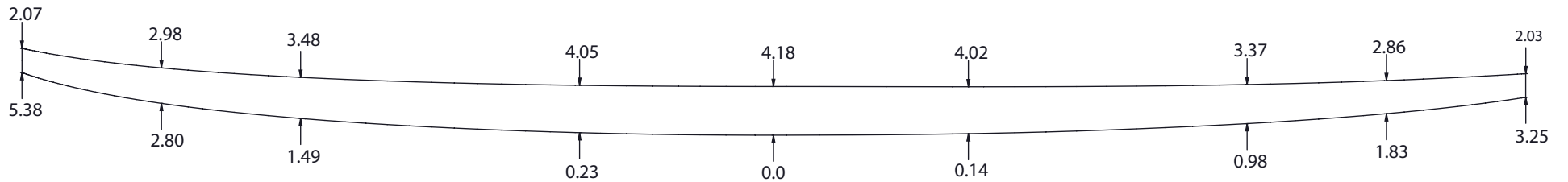
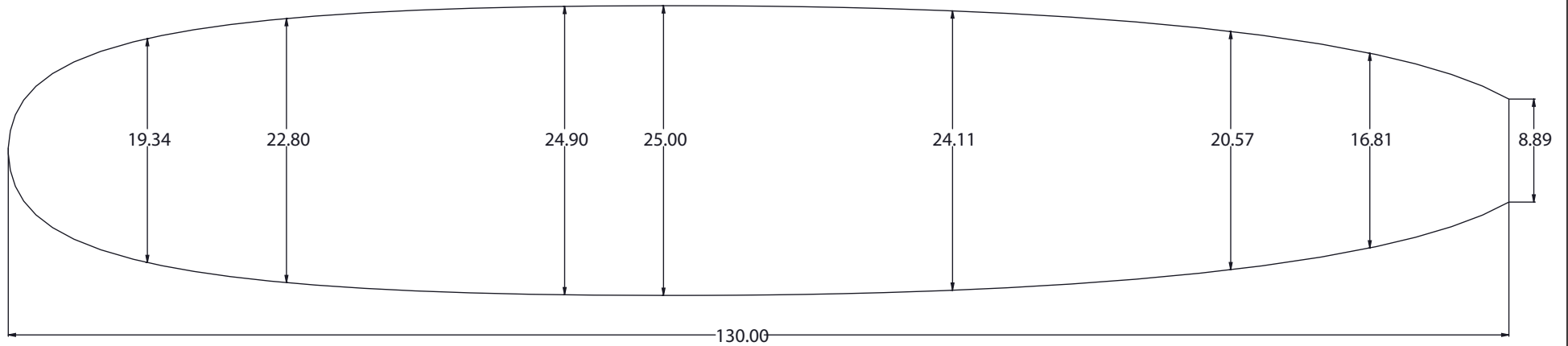

AVAILABLE DENSITIES:

*refer to density chart

STOCK STRINGER:

1/8" Bass

Updated 5-11-16

SHAPER'S COMMENTS:

A blank made perfectly for your next longboard. With plenty of width and thickness it is perfect for a mellow cruiser or a high performance log. This blank is cut out of block EPS on a computer controlled hotwire machine to ensure the same blank dimensions everytime.

THIS INFORMATION IN THIS DRAWING IS THE SOLE PROPERTY OF marko foam ANY REPRODUCTION IN PART OR AS A WHOLE WITHOUT THE WRITTEN PERMISSION OF marko foam IS PROHIBITED

100% RECYCLABLE

TITLE:

MK- 10'10"

SHAPER:

Marko Foam

7'10 GUN

BLOCK CUT EPS

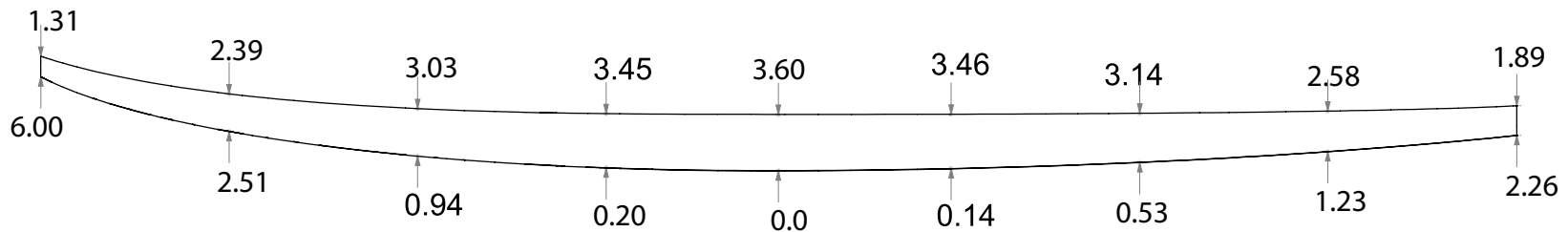
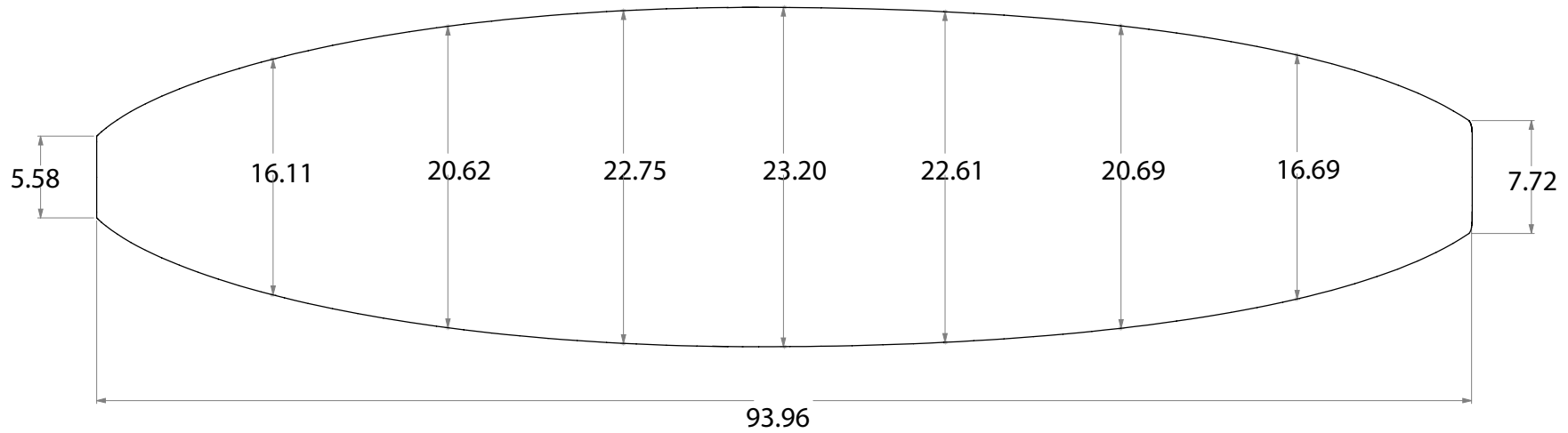

AVAILABLE DENSITIES:

*refer to density chart

STOCK STRINGER:

1/4" Bass

Updated 5-11-16

SHAPER'S COMMENTS:

If your looking to charge some big waves you've found the right blank. With enough rocker to make the drop and an outline made for speed there's no wave the gun blanks can't handle. Go big or go home!

THIS INFORMATION IN THIS DRAWING IS THE SOLE PROPERTY OF marko foam ANY REPRODUCTION IN PART OR AS A WHOLE WITHOUT THE WRITTEN PERMISSION OF marko foam IS PROHIBITED

100% RECYCLABLE

TITLE:

7'10" Gun

SHAPER:

Marko Foam

8'0" GUN

BLOCK CUT EPS

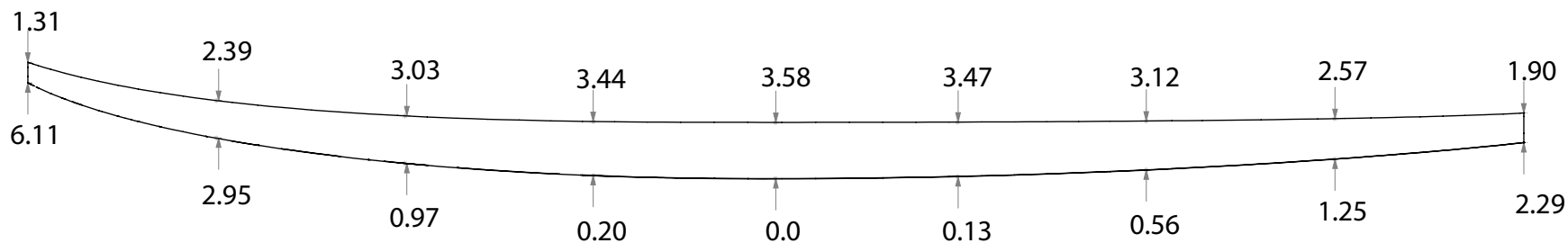
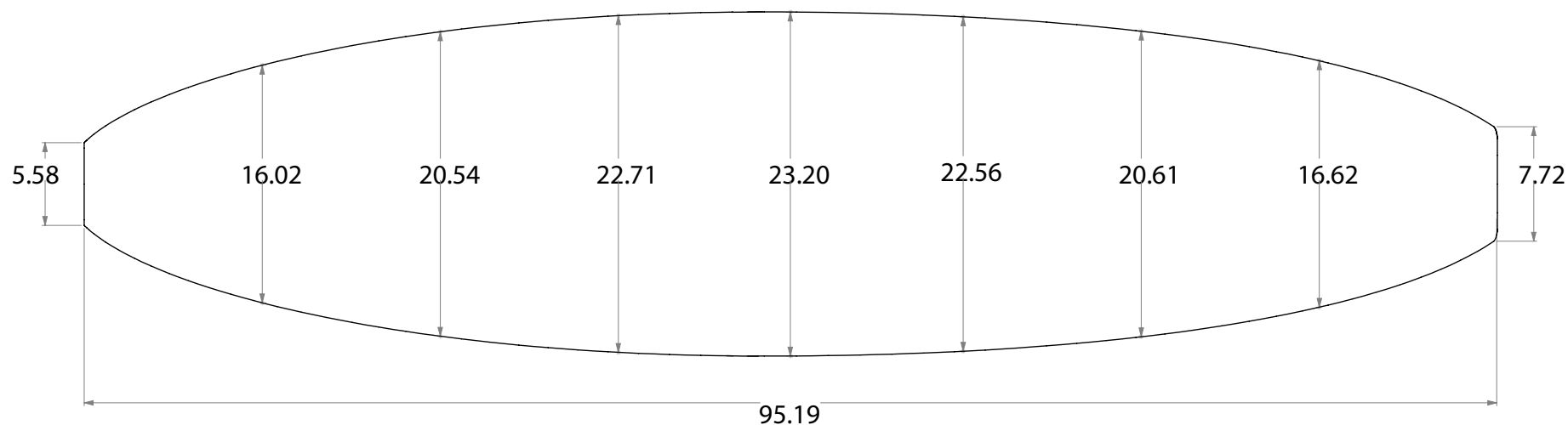

AVAILABLE DENSITIES:

*refer to density chart

STOCK STRINGER:

1/4" Bass

Updated 5-11-16

SHAPER'S COMMENTS:

If your looking to charge some big waves you've found the right blank. With enough rocker to make the drop and an outline made for speed there's no wave the gun blanks can't handle. Go big or go home!

THIS INFORMATION IN THIS DRAWING IS THE SOLE PROPERTY OF marko foam ANY REPRODUCTION IN PART OR AS A WHOLE WITHOUT THE WRITTEN PERMISSION OF marko foam IS PROHIBITED

100% RECYCLABLE

TITLE:

8'0" Gun

SHAPER:

Marko Foam

8'6" GUN

BLOCK CUT EPS

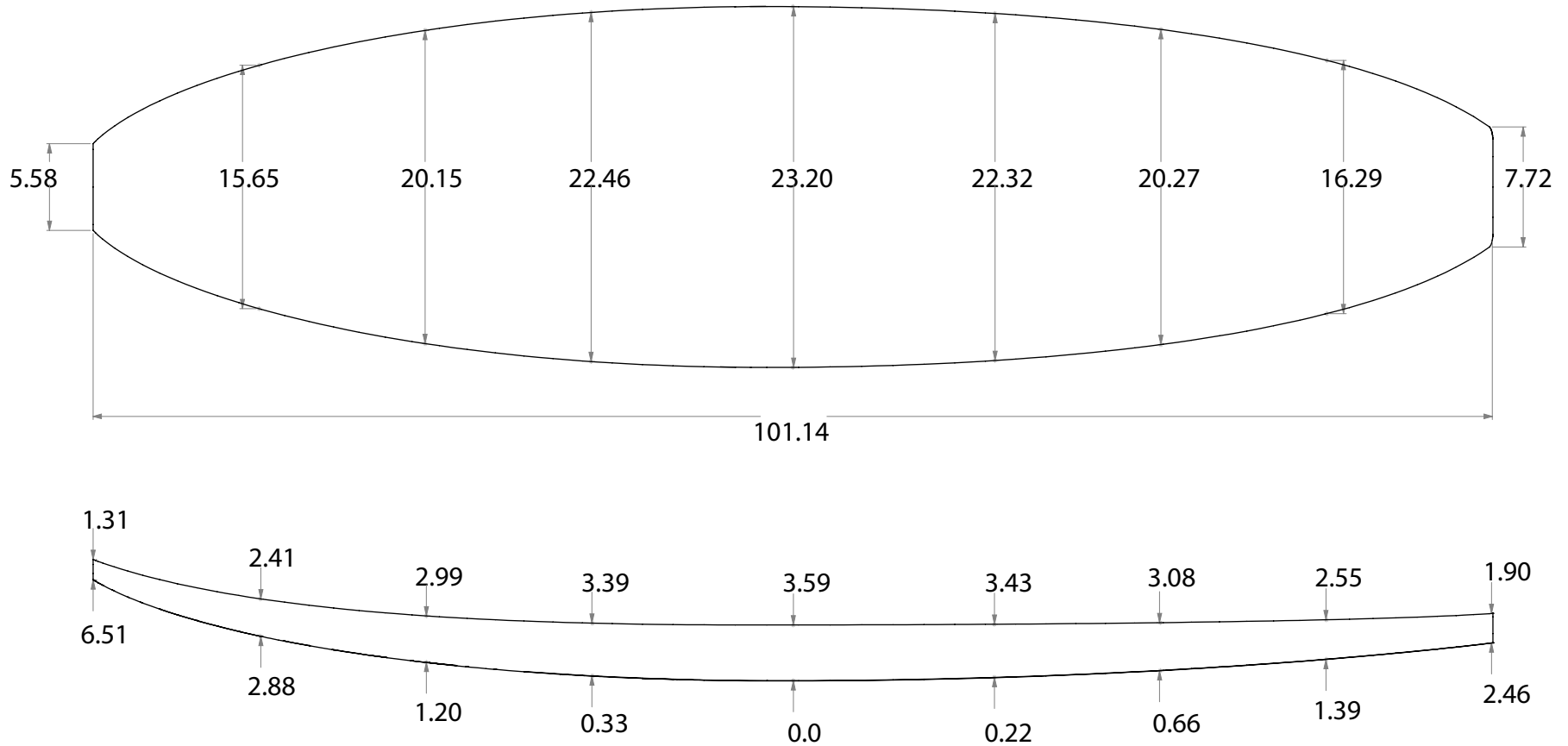

AVAILABLE DENSITIES:

*refer to density chart

STOCK STRINGER:

1/4" Bass

Updated 5-11-16

SHAPER'S COMMENTS:

If your looking to charge some big waves you've found the right blank. With enough rocker to make the drop and an outline made for speed there's no wave the gun blanks can't handle. Go big or go home!

THIS INFORMATION IN THIS DRAWING IS THE SOLE PROPERTY OF marko foam ANY REPRODUCTION IN PART OR AS A WHOLE WITHOUT THE WRITTEN PERMISSION OF marko foam IS PROHIBITED

100% RECYCLABLE

TITLE:

8'6" Gun

SHAPER:

Marko Foam

9'0" GUN

BLOCK CUT EPS

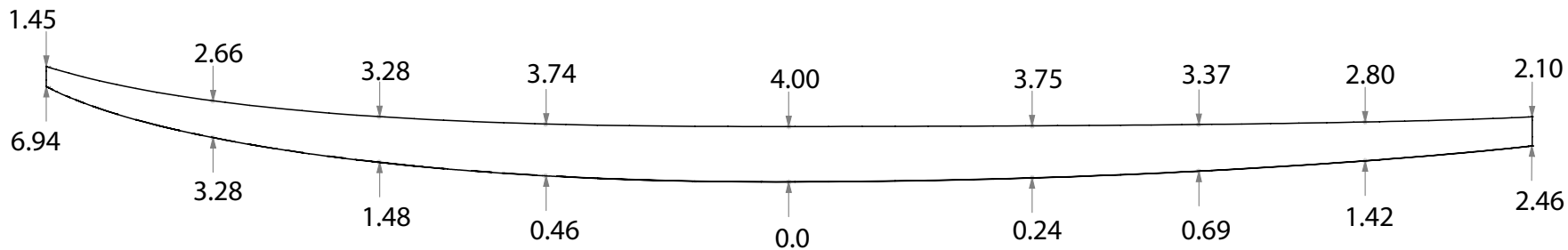
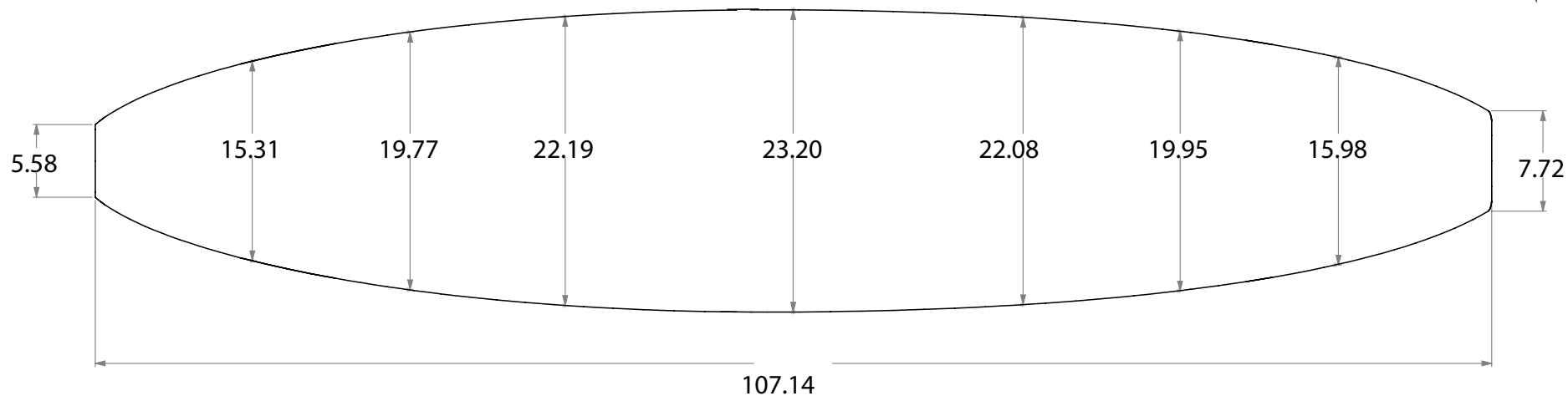

AVAILABLE DENSITIES:

*refer to density chart

STOCK STRINGER:

1/4" Bass

Updated 5-11-16

SHAPER'S COMMENTS:

If your looking to charge some big waves you've found the right blank. With enough rocker to make the drop and an outline made for speed there's no wave the gun blanks can't handle. Go big or go home!

THIS INFORMATION IN THIS DRAWING IS THE SOLE PROPERTY OF marko foam ANY REPRODUCTION IN PART OR AS A WHOLE WITHOUT THE WRITTEN PERMISSION OF marko foam IS PROHIBITED

100% RECYCLABLE

TITLE:

9'0" Gun

SHAPER:

Marko Foam

9'6" GUN

BLOCK CUT EPS

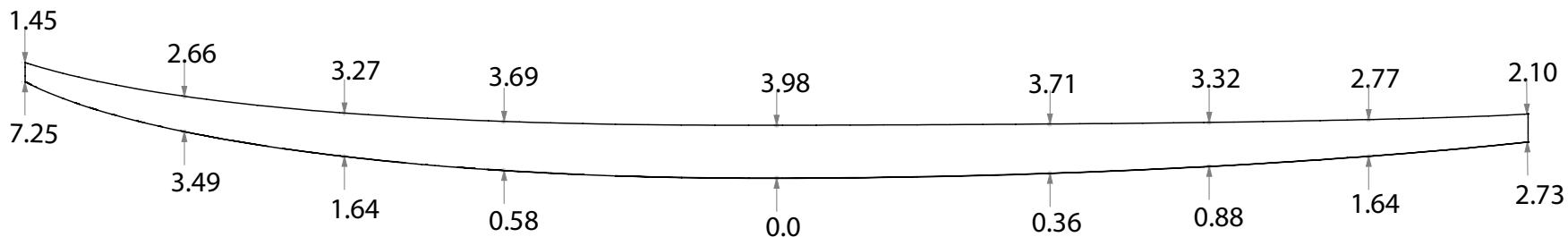
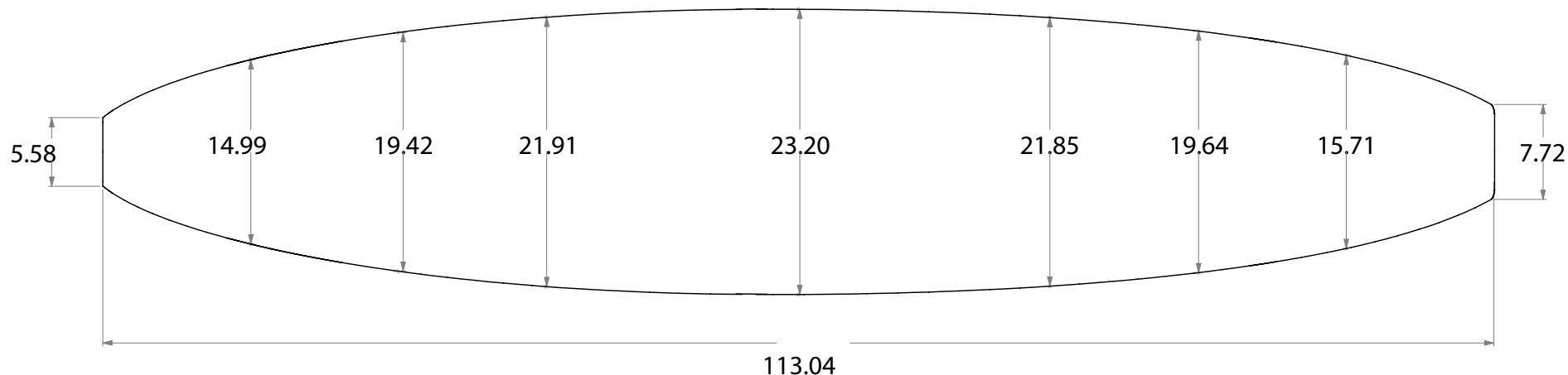

AVAILABLE DENSITIES:

*refer to density chart

STOCK STRINGER:

1/4" Bass

Updated 5-11-16

SHAPER'S COMMENTS:

If your looking to charge some big waves you've found the right blank. With enough rocker to make the drop and an outline made for speed there's no wave the gun blanks can't handle. Go big or go home!

THIS INFORMATION IN THIS DRAWING IS THE SOLE PROPERTY OF marko foam ANY REPRODUCTION IN PART OR AS A WHOLE WITHOUT THE WRITTEN PERMISSION OF marko foam IS PROHIBITED

100% RECYCLABLE

TITLE:

9'6" Gun

SHAPER:

Marko Foam

MOLDED PLANK

PRESSURE MOLDED EPP

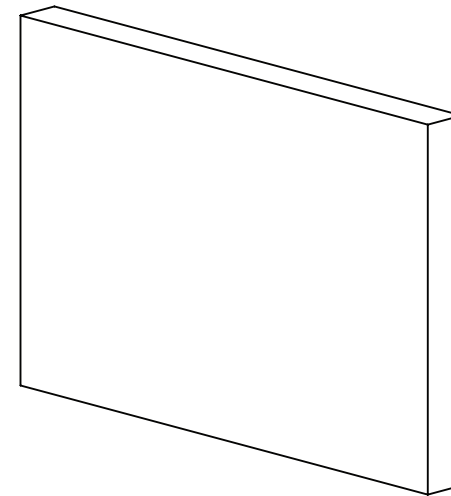
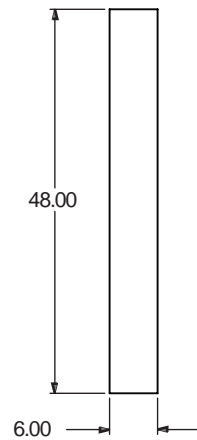
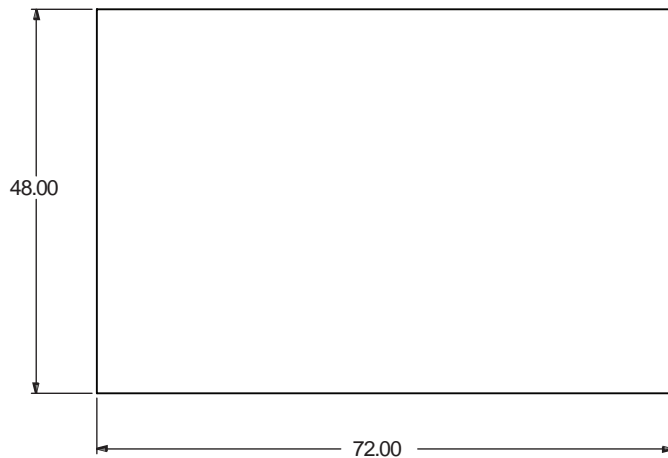
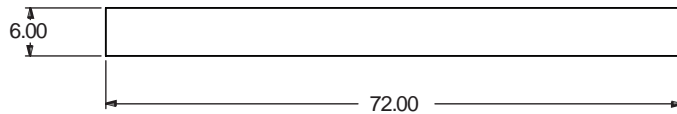

AVAILABLE DENSITIES:
1.3, 1.9

SHAPER'S COMMENTS:

This plank can be ordered as is or cut to specified dimensions. Good yield for many watersports applications.

MATERIAL:
EPP/EPE

Updated 5-6-16

THIS INFORMATION IN THIS DRAWING IS THE SOLE PROPERTY OF marko foam ANY REPRODUCTION IN PART OR AS A WHOLE WITHOUT THE WRITTEN PERMISSION OF marko foam IS PROHIBITED

100% RECYCLABLE

TITLE:	SHAPER:
MOLDED PLANK	Marko Foam

BODYBOARD CORE

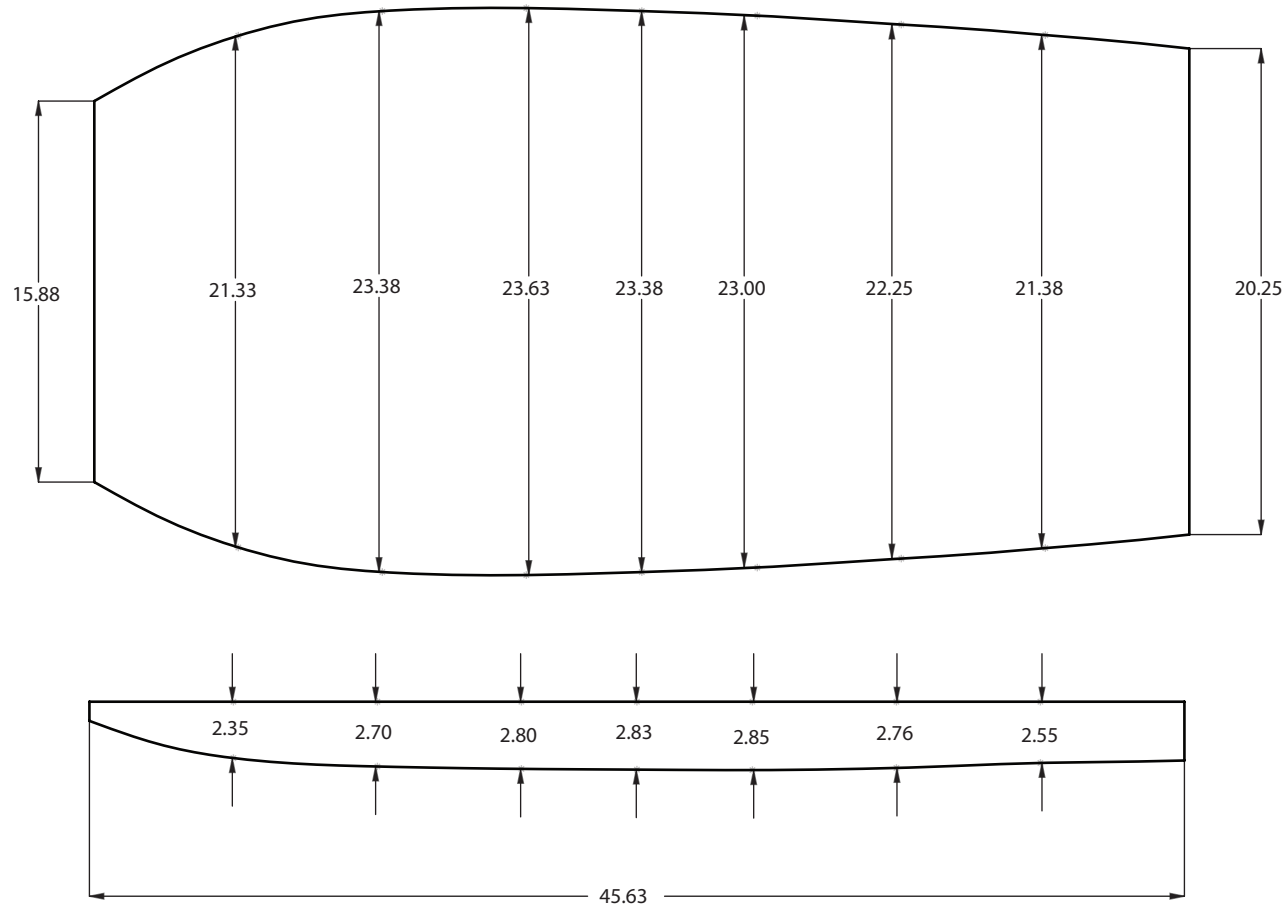

AVAILABLE DENSITIES:
2.0, 2.2 // Special densities available upon request

SHAPER'S COMMENTS:
Bodyboard cores can be sanded to specified thickness. Typical thickness is 2.0"

MATERIAL:
IFOAM / EPS

Updated 5-6-16

THIS INFORMATION IN THIS DRAWING IS THE SOLE PROPERTY OF marko foam ANY REPRODUCTION IN PART OR AS A WHOLE WITHOUT THE WRITTEN PERMISSION OF marko foam IS PROHIBITED

100% RECYCLABLE

TITLE:	SHAPER:
BODYBOARD CORE	Marko Foam