

EcoFan®

Product Manual

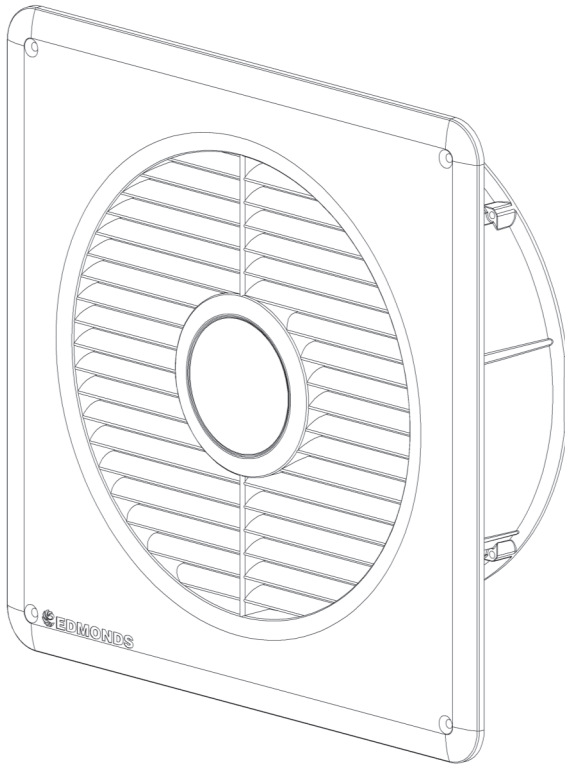

Item Checklist

Included Parts:

QTY:

1	EcoFan™	(1)
2	Speed Controller	(1)
3	Power Supply	(1)
4	10m Low Voltage Extension Lead	(1)
5	Speed Controller Fixing	(2)
6	6mm Wall Plugs	(4)
7	8Gx32mm CSK Screws	(4)
8	Product Manual	(1)
9	Warranty Document	(1)

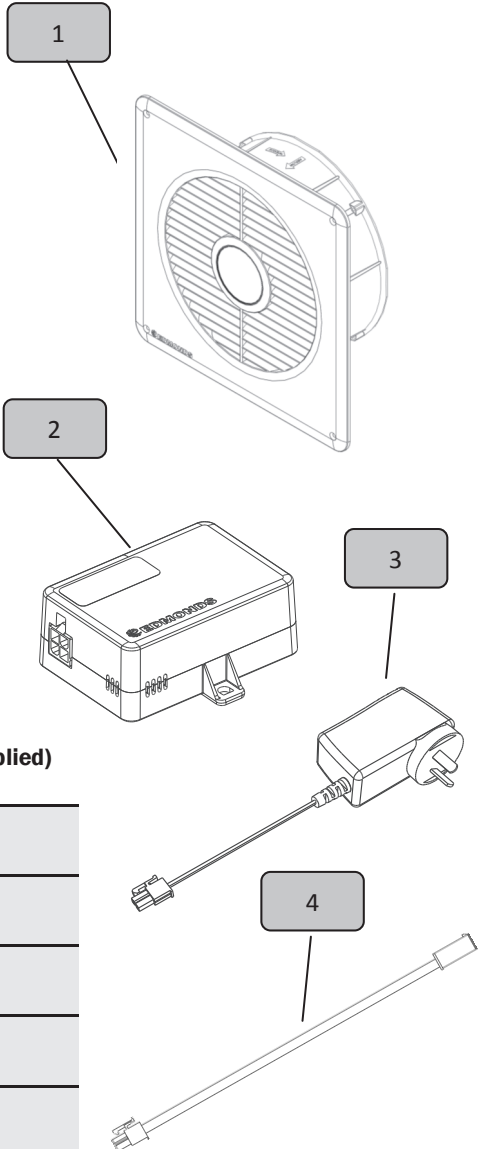

Additional Parts & Tools Required (Not Supplied)

Hammer
Impact Drill & 6mm Masonry Drill Bit
Screwdriver with Phillips (P2) Bit
Marker Pen
Cable Ties

WARNING: Do not proceed with the installation until you have read the entire instructions, including these warnings.

Install at your own risk

The installation of this product may be dangerous and includes the potential of personal injury or property damage. Please take care when installing this product and be mindful of risks. Please be aware of the following when installing this product.

- Installation requires the cutting and removal of bricks. This process can produce airborne debris and other hazards. To minimise risks wear appropriate personal protection equipment such as appropriate eye protection, gloves and a dust mask.
- When selecting a location for the EcoFan™ make sure that the area is clear of services such as pipes and power cables.
- Only install into non structural sections of walls. Ensure wall is not load bearing.

Important Notes

- The EcoFan™ is designed for general household ventilation only. DO NOT use to exhaust hazardous or explosive materials and vapours.
- One side of the EcoFan™ has an unguarded fan assembly. DO NOT use in locations that expose the unguarded side to areas readily accessible to people or animals.
- Always use the provided power supply and speed controller to power the fan. Failure to do so can damage the product.
- Ensure that the power supply and speed controller are not left on damp surfaces, fasten to available structure with cable ties if required.
- Only use one EcoFan™ per speed controller and power supply.

Installation

STEP 1

Select appropriate position. Using the fan housing as a guide, mark out a circle/location on the wall.

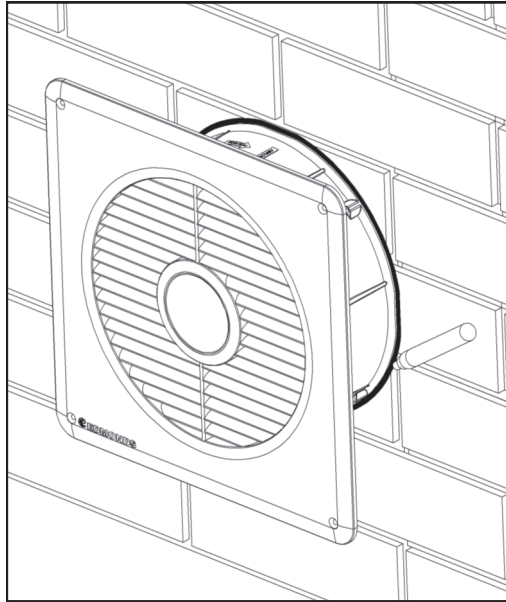

STEP 2—Option A

Using an impact drill and 6mm drill bit. Drill holes spaced 3-4 cm around the marked perimeter.

Using a hammer carefully knock out the bricks to form a circular hole in the wall.

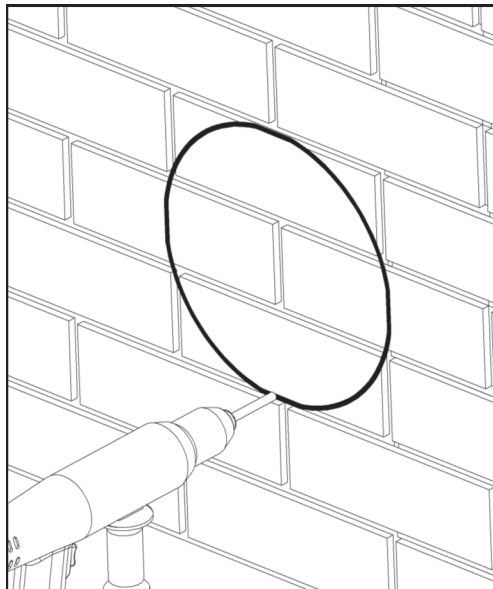

Installation

STEP 2—Option B

Remove the complete top and bottom shaded bricks.
Cut and remove the middle shaded bricks.

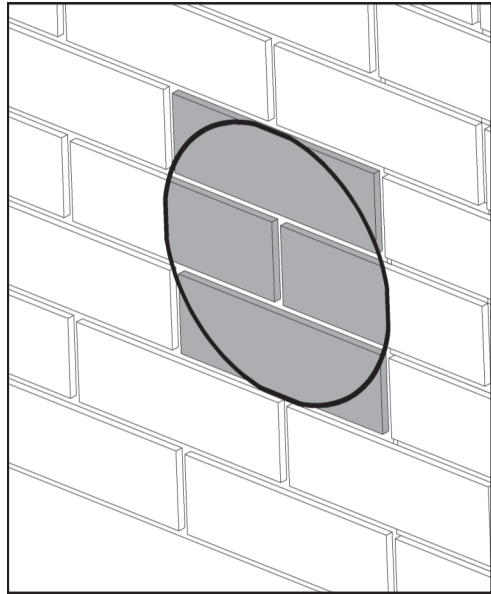

STEP 3

Clear the hole of debris.

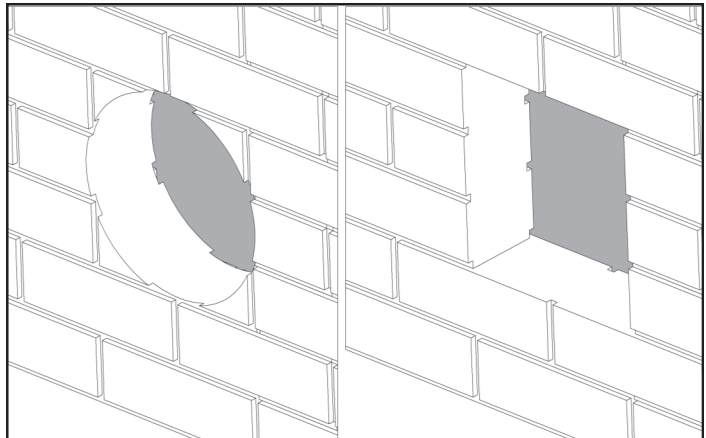

Installation

STEP 4

Insert the EcoFan™ into the hole. Make sure it is level and the correct way up. Mark the positions of the mounting holes.



The back of the wall grille has a mark to indicate correct orientation.

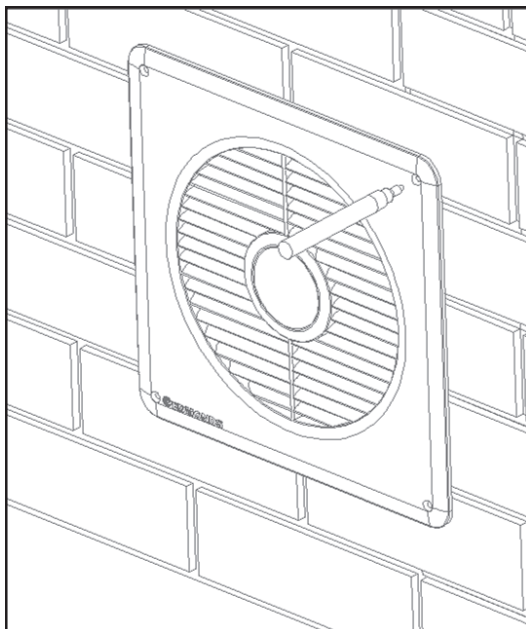

STEP 5

Remove the unit and using a 6mm masonry bit, drill mounting holes as marked previously.

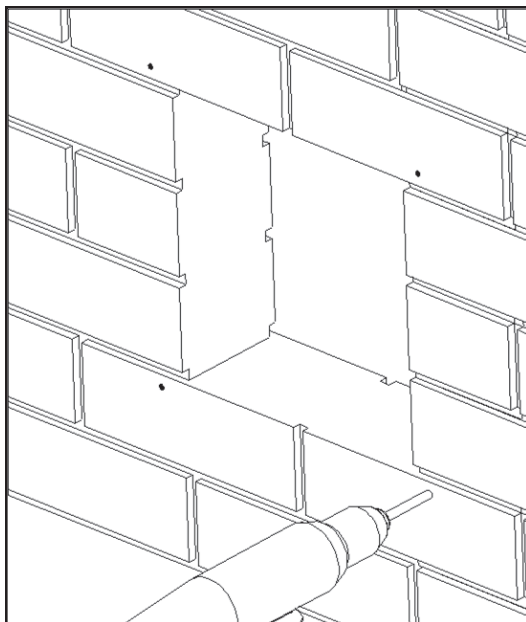

Installation

STEP 6

Insert supplied wall plugs into the 6mm drilled mounting holes.

Tap into hole with hammer until flush.

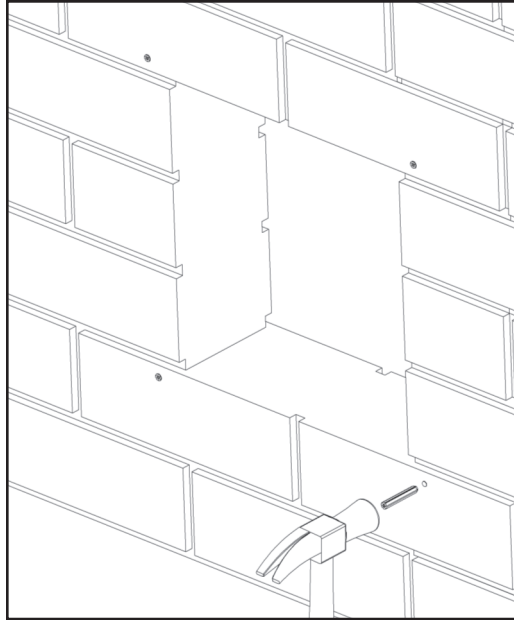

STEP 7

Using the supplied screws, screw the EcoFan™ into the wall plugs.

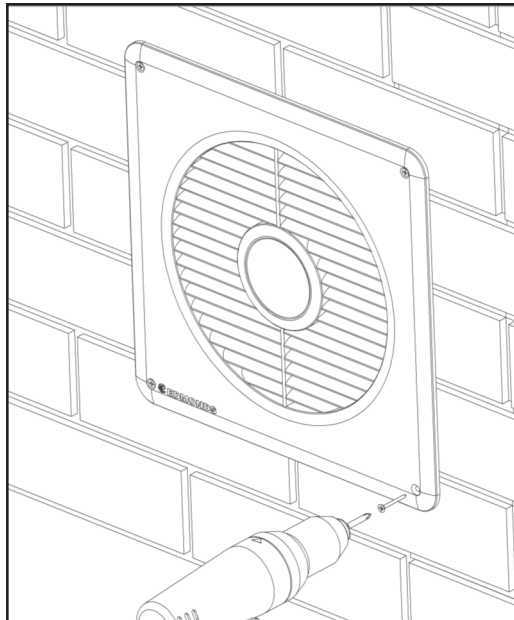

Installation—Electrical Connection

STEP 1

Connect the lead coming from the EcoFan unit to the speed controller

STEP 2

Connect the extension lead to the speed controller.

STEP 3

Connect the power supply lead to the extension lead.

STEP 4

Connect the power supply to a mains socket. Turn on and check fan runs freely.

STEP 5

Using either the screws supplied or cable ties mount the speed controller and the power supply in a suitable location that prevents them from getting wet.

STEP 6

Set the control mode by pressing the button on the side of the speed controller.

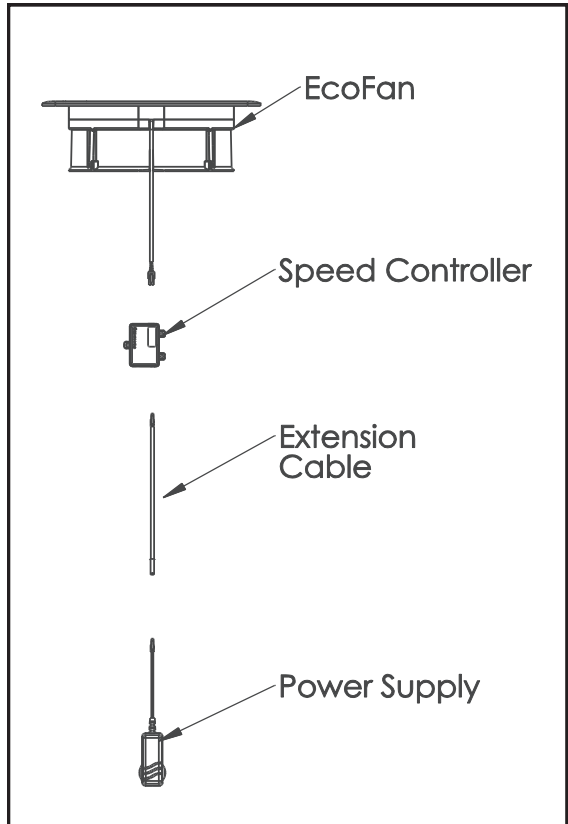
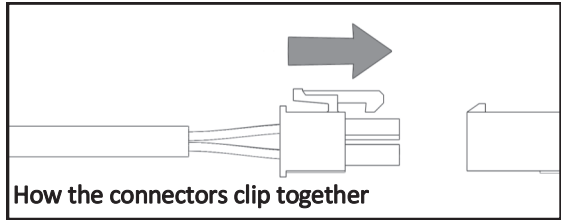

Ensure the power supply and speed controller are not in contact with damp or wet surfaces.

Installation—Speed Control Mode

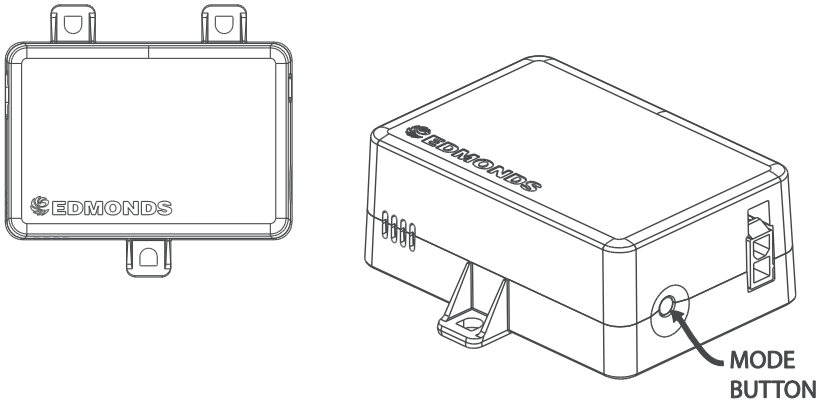

The speed controller has 4 operating modes. These can be cycled through by pressing the button on the speed controller

The order of modes are: LO, MED, HI, AUTO. When engaging AUTO mode the fan will speed up to full speed and then slow down to a stop to provide feedback that AUTO has been selected. Once this startup procedure is complete the fan will analyse the environment and run at the appropriate speed.

MODES:

- LO (Default)** - Continuous operation, low speed, low flow rate, very quiet, very low power consumption.
- MED** - Continuous operation, moderate speed, moderate flow rate.
- HI** - Continuous operation, high speed, high flow rate.
- AUTO** - Variable speed. The EcoFan will automatically increase or decrease the speed of the fan depending on the subfloor temperature (30°C–45°C) and subfloor relative humidity (65%RH–80%RH).



In AUTO mode the EcoFan will run based off the environmental conditions. When the conditions are deemed suitable for no ventilation the unit will enter a power savings mode and the motor will not run.

Convert From Exhaust to Supply Flow Direction

STEP 1

Remove the 4 screws fixing the fan housing to the wall grille.

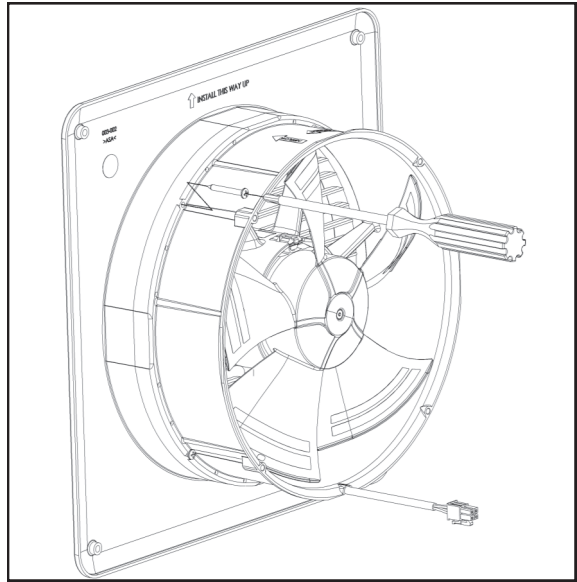

There are arrows on the motor housing that indicate the direction of airflow

STEP 2

Reverse the fan housing and using the same screws mount the housing to the wall grille.

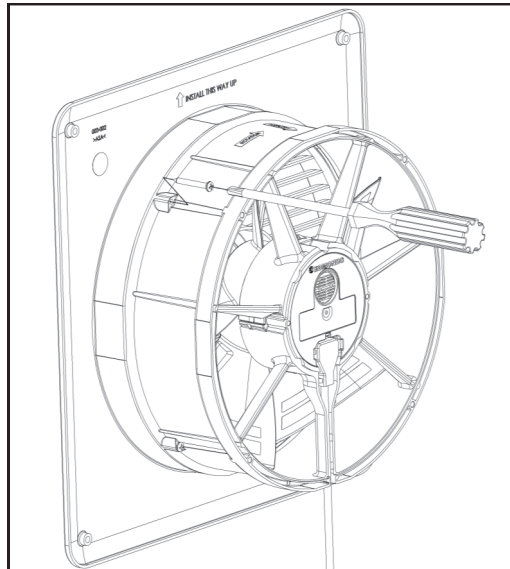

The motor cable should always be pointing downwards.

Removing Wall grille for Painting

STEP 1

Remove the 4 screws fixing the fan housing to the wall grille.

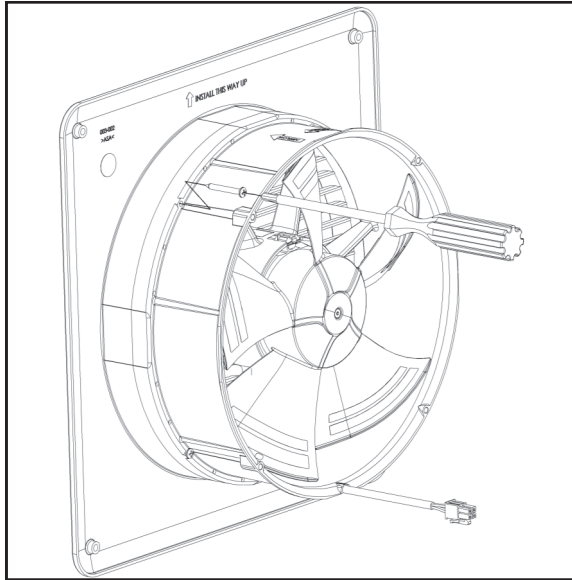

The plastic used for the wall grille is suitable for painting with standard spray paints without priming. The surface must be clean before painting.

STEP 2

Paint wall grille and allow to dry.

Reattach the wall grille to the fan housing using the screws removed earlier (Step 1 in reverse).

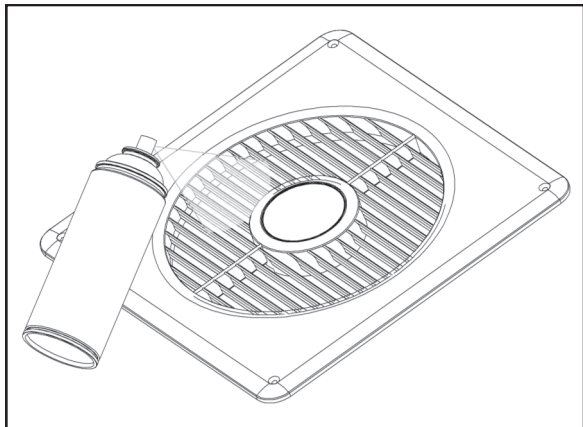

Technical Data

Material:

Wall Grille:	Plastic (ASA)
Fan & Motor Housing:	Plastic (PP-TD20)
Fan Impeller:	Plastic (PA6-GF30)
Screws:	Stainless Steel (304)

Weight:

1.5 kg

Electrical:

Power Supply

Type:	Electronic Switching Mode
Input:	100-240VAC, 1~, 50/60Hz, 2A
Output:	24 VDC

Fan Motor:

	Electronic Commutating (EC) motor
Internal Voltage:	24 VDC
Protection Class:	IP54

Speed Control

Type:	Temperature & Humidity Sensing Electronic Variable Speed Controller
Input Voltage:	24 VDC
Fixed Speed Operation:	Three fixed speeds (LO, MED & HI), manually selectable via button
Automatic Variable Speed Operation:	Variable speed response relative to environmental conditions of speed controller location. - See tech data sheet for additional information.

Performance Data & Product Dimensions

Speed	Sound Pressure Level (SPL) L_A @ $p_{sF}=0$ [dB(A)]	Max. running power consumption [W]	Flow rate q_v @ $p_{sF}=0$ [m ³ /hr]
LO	32.8	6.9	280
MED	43	16.1	457
HI	53.5	37	734

NOTE—Sound pressure level measured 1m from fan inlet

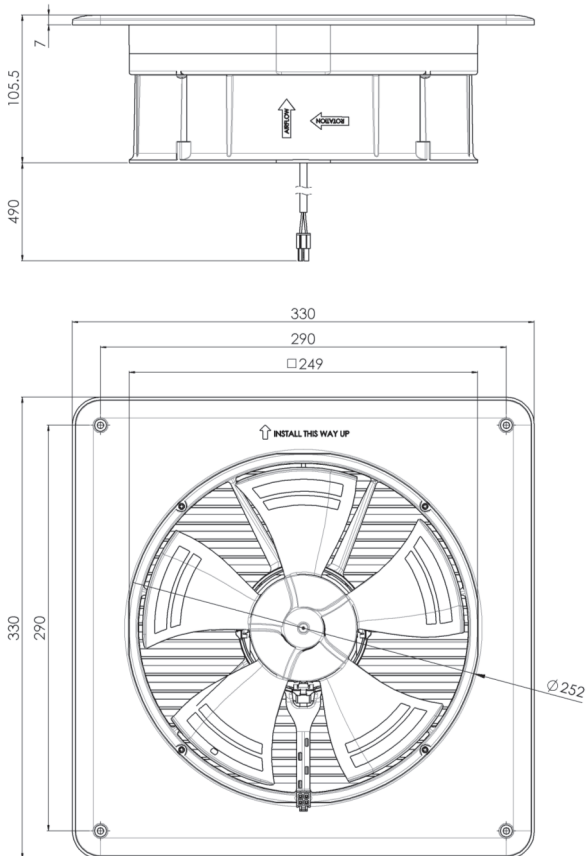

FAQ & Troubleshooting

Q: Do I need an electrician to install the EcoFan™?

A: If you have an available power point that can be reached then no electrician is required. If a power point is unavailable then an electrician will be required to install one.

Q: Can I wire it directly into the mains power?

A: No, you must use the supplied power supply and speed controller for the EcoFan™ to work correctly. Failure to do so may damage the product.

Q: Can I duct the EcoFan™?

A: Yes the EcoFan™ can be ducted in either exhaust or inlet mode by slipping 250mm diameter ducting over the lip of the motor housing and fixing with tape.

Q: Can I paint the EcoFan™?

A: Yes, standard spray paint can be used to paint the EcoFan™. No plastic primer is required, however the surface must be clean before paint application. Do not get any paint on the motor/fan module. The product should be disassembled to facilitate easier painting. Instructions on disassembly can be seen on page 11 of this manual.

Troubleshooting	
Problem	Possible Actions
Motor / Fan Not Running	Controller may be in AUTO mode and may have determined that no ventilation is necessary. Change to LO to confirm controller is functioning
	Check all connections are secure
	Check Power supply is plugged in
	Check Power Socket is turned on

Contact Details

General Enquiries and Support

PH: 1300 760 233

Email: sales@csr.com.au

Technical Ventilation Enquiries

PH: 1800 354 044

Please fill out for your reference in case support is required	
Serial Number	Purchase Date
_____	___ / ___ / ___

October 2019

I-041-B



Bradford is a business division of CSR Building Products Limited ABN 55 008 631 356
10 Stanton Road, Seven Hills NSW 2147 Australia | www.bradfordventilation.com.au

bradfordventilation.com.au

