

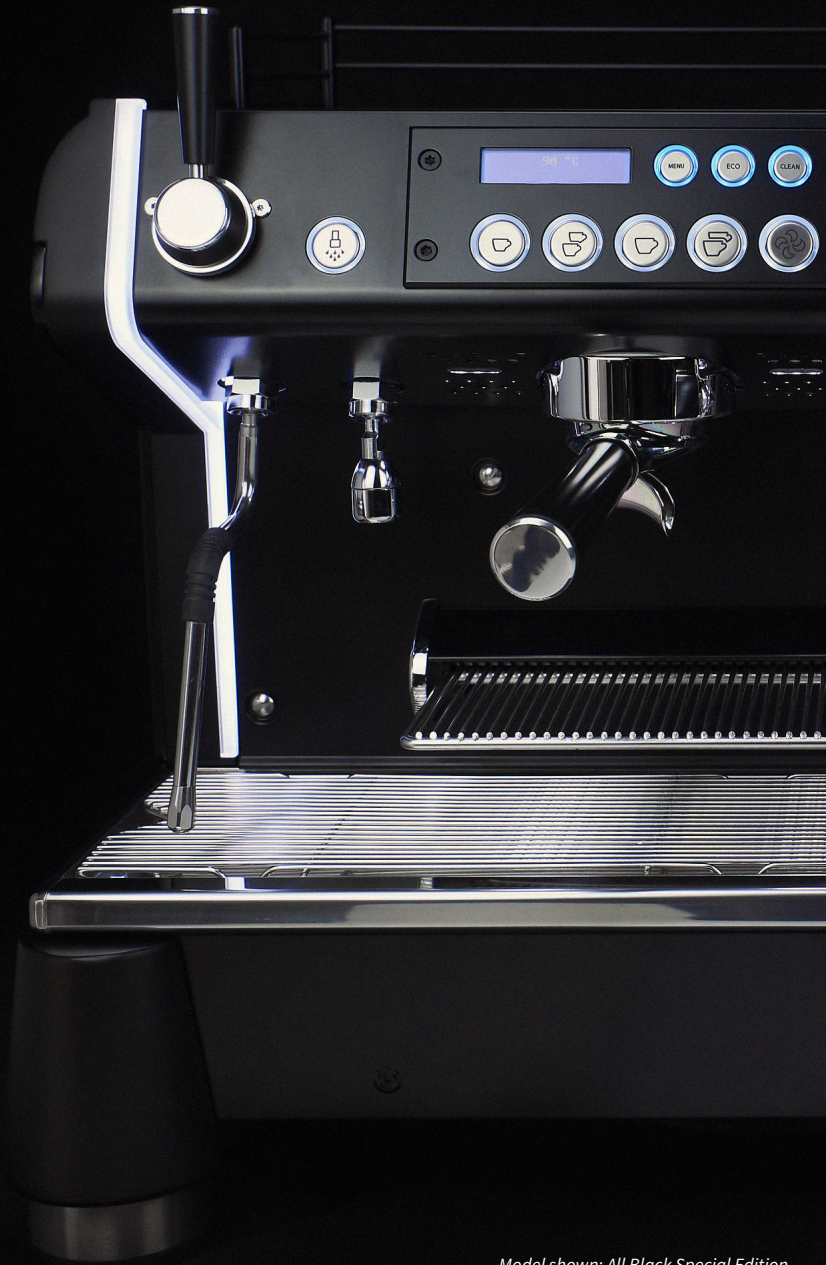

# Monte Carlo

PRECISE,  
STYLISH &  
INTUITIVE



*Model shown: All Black Special Edition*



Nestled quietly within the heart of Monaco is our small, but perfectly formed factory, hand-crafting espresso machines since 1956. We combine a genuine passion for innovation and coffee excellence, with exceptional quality and reliability to produce the finest machines for any circumstance or environment.

[www.sbsolutions.ca](http://www.sbsolutions.ca)







# Monte Carlo



The Monte Carlo is a culmination of over 60 years of research and design. Created to meet the demanding needs of baristas and roasters worldwide, the Conti Monte Carlo combines great design, endless power, and extreme precision.

Conceived for the most discerning barista, coffee roaster and cafe/restaurant operator, the Monte Carlo has a harmonious combination of style, practicality, precision-built quality, and advanced technology to ensure it is a future-proof consideration for any application.



### Multi Boiler, Triple Heat Zone System

Each coffee boiler and coffee group is accurately temperature controlled by its own PID system and supplied with preheated water from its unique heat exchange system. The Monte Carlo ensures perfect precision for your coffee every time. Each group acts independently, thus, allowing the user to offer perfect brew temperatures for coffees of different origin or roast profile, with these settings accessed quickly and easily via the intuitive touchpad menus.



### Soft Pre-Infusion

Intended to replicate the simplistic but ultimately effective one-way pre-infusion found in the original lever-style espresso machine, the Monte Carlo's in-house system ensures the barista can fully saturate the coffee puck under controlled low pressure. This results in incredibly consistent extraction, reduction in channelling and espresso with increased body and better mouth feel.



### Accumetrix

Our own, in-house volumetric system enables the machine to accurately read the volume of brewed espresso in the cup. This removes the need to weigh every extraction, improving workflow and consistency. Designed to detect resistance in flow rate, the software accurately responds to the flow meter and displays exact shot volume on independent touchpad screens above each coffee group. The adjustable interface means it can show details of each extraction, including shot time, volumetrics, and flow rate.

### Additional Features

#### Cool Touch Steam Wands

Enables the barista to work safely by eliminating steam burns, while ensuring the best possible hygiene levels thanks to the non-stick low temperature surface.

#### Conti Excellium Non-stick Coated Portafilters

The non-stick treatment helps prevent buildup of coffee oils which can taint espresso flavour.

#### Multi-Level User Interface

With an independent group interface and full diagnostic touchscreen, the Monte Carlo can be finely tuned to suit any environment. Simply decide your settings, then lock down the touchscreen to avoid any accidental changes.

#### Barista Comforts

From barista lights, retractable cup stands and auto clean modes, to the separate Eco modes for each coffee group, the Monte Carlo has been designed with feedback from baristas around the globe.

#### Precision

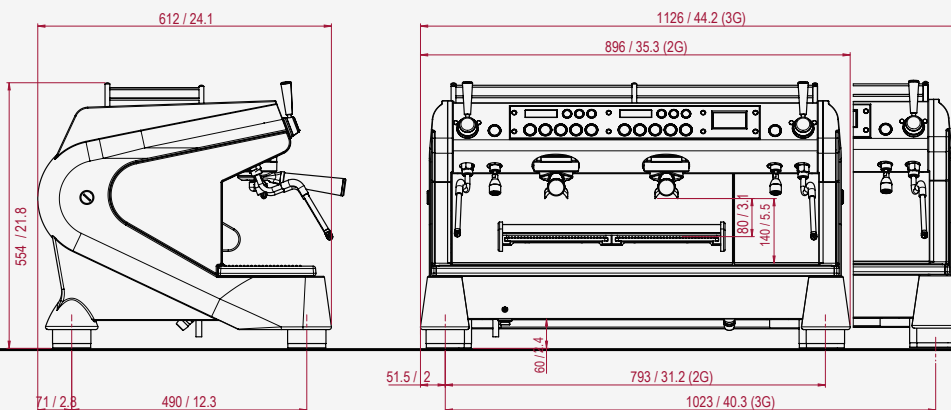

Competition standard shower plates and baskets – machined and packaged exclusively for Conti by IMS. These components have exacting build criteria to ensure an even extraction. The exacting hole diameter and polished inner surface perforations help avoid any obstruction during the brewing process producing a more consistent, homogenous shot every time.





|                             | 2 Group      | 3 Group      |
|-----------------------------|--------------|--------------|
| Height (mm/in)              | 554 / 21.8   | 554 / 21.8   |
| Width (mm/in)               | 896 / 35.3   | 1126 / 44.3  |
| Depth (mm/in)               | 612 / 24.1   | 612 / 24.1   |
| Weight (kg / lbs)           | 86 / 189.6   | 103 / 227.0  |
| Steam Boiler Size (Litres)  | 10           | 14           |
| Coffee Boiler Size (Litres) | 0.9 x 2      | 0.9 x 3      |
| Group Element (W)           | 100          | 100          |
| Steam Boiler Element (W)    | 4200         | 6000         |
| Coffee Boiler Element (W)   | 1000         | 1000         |
| Total Power (W)             | 1900-6700*   | 2600-9600*   |
| Voltage (V / Amp / Ph)      | 230 / 30 / 1 | 230 / 30 / 1 |

\*Please note total power can be adjusted within power management.

### Colour Options

-  Matte Jet Black
-  Matte Traffic White
-  Custom RAL

### Special Editions

-  All Black
-  Wood Finish



## Specialty Beverage Solutions

Email: [sales@sbsolutions.ca](mailto:sales@sbsolutions.ca)

Tel: 1.888.805.5528

[www.sbsolutions.ca](http://www.sbsolutions.ca)

7519 Flint Road SE

Calgary, AB T2H 1G3

 @specialtybeveragesolutions

 specialtybeveragesolutions