

# **CC100**

## **DISPLAY**



## **TECHNICAL DOCUMENT**

**CONTI - Edition 05/2015**

SACOME, Document CONFIDENTIEL, Ne peut être reproduit ni communiqué sans notre accord préalable.  
SACOME, CONFIDENTIAL Document, it is forbidden to duplicate or communicate this document without previous authorization.

<b>Table des matières</b>	<b>Page</b>
1. TECHNICAL DOCUMENTS _____	2
2. DIMENSIONS _____	2
3. CAUTION DURING THE USE _____	3
4. INSTALLATION _____	4
5. OPERATION _____	6
6. HOW TO USE THE MACHINE _____	7
7. PROGRAMMING OF COFFEE DOSAGE _____	9
8. RELATED FONCTIONS _____	10
9. PROGRAMMING PARAMETERS OF TECHNICAL MENU: _____	12
10. SUMMARY OF THE PROCEDURE RESETTING THE COUNTERS _____	17
11. DESCRIPTION OF ALARMS _____	18
12. HOW TO MAKE THE PERFECT COFFEE _____	19
13. MAINTENANCE OF MACHINES _____	21
14. ELECTRONIC DIAGRAM _____	24
15. HYDRAULIC SCHEMA _____	28
16. OPTION AVAILABLE _____	29

## 1. TECHNICAL DOCUMENTS

TYPE MACHINE	HEATING POWER (W)	INSTALLED POWER (W)	ELECTRICAL CONSUMPTION With 230V (A)
CC102 D	3500	3800	17A
CC103 D	4700	5000	22A
CC103 D Tri	6000	6300	10A / phase

BOILER CAPACITY ( LITERS)		
	2G	3G
TOTAL	11	18
VOLUME OF HOT WATER	8	13
VOLUME OF STEAM	3	5

	WEIGHT empty (Kg)	WEIGHT in operation (Kg)
CC102	58	69
CC103	72	90

## 2. DIMENSIONS

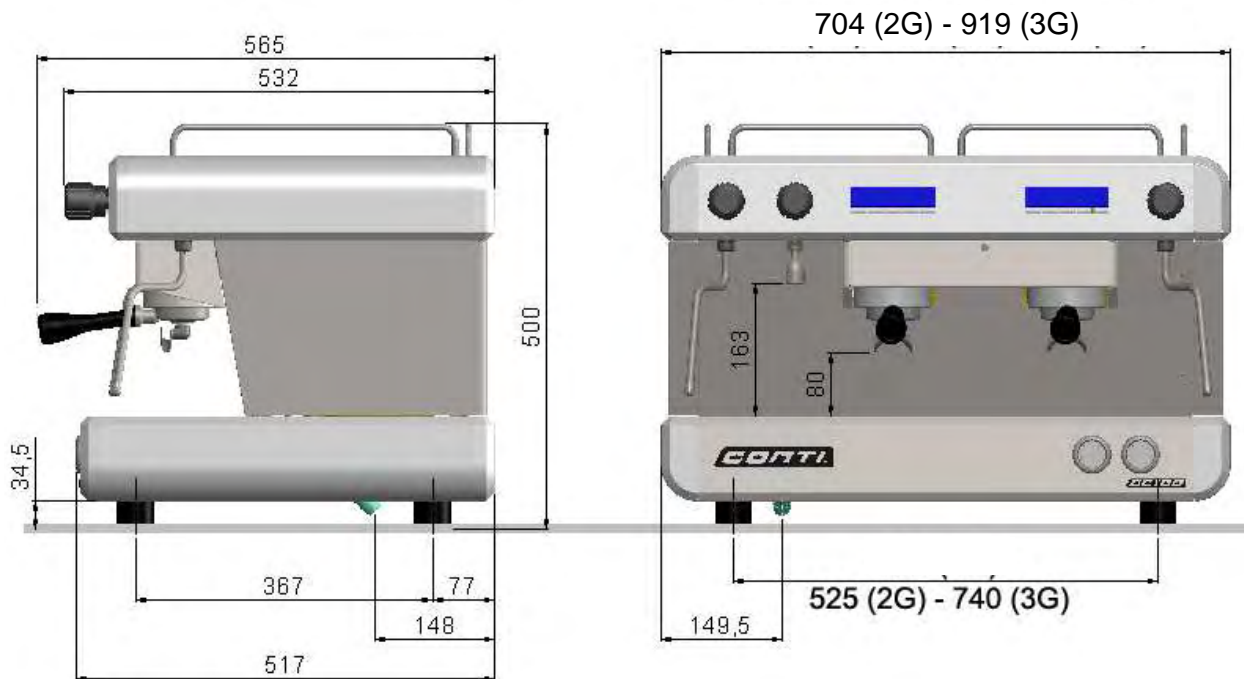

### 3. CAUTION DURING THE USE

#### 3.1. AMBIENT CONDITIONS

- The ambient temperature around the machine had to be between 5°C et 32°C.
- The ambient humidity must not exceed 70 %
- The machine must be placed such as the cup warmer is located more than 1.5 meters from the ground.

#### 3.2. DURING INSTALLATION

- The installation (electrical connections, water supply and drainage) must be carried out by a qualified technician approved by CONTI.
- The machine must be connected to a device conforming to the standards of the country where the machine is installed. Potential costs of equipment compliance are the only responsibility of the customer.
- For any technical intervention, the machines must always have the power disconnected from the mains.
- An effective earth connected to the terminal provided for this purpose on the device is mandatory
- A screw located under the bottom base machine, allow if necessary, to connect several machine on an equipotential way.
- Devices for disconnection from the main supply, having a contact separation of at least 3mm in all poles, must be provided in the fixed wiring in accordance with the installation rules.



#### 3.3. DURING THE USE

- When the machine is not operating, the water cut-off valve has to be closed and the electrical power supply cut.
- When the machine is not supervised it must be disconnected from the power and water supply.
- Never disconnect the earthing when the machine is connected to the power supply.
- Machines must always be disconnected from the main power, in case of technical interventions.

#### 3.4. RULES RELATING TO THE ENVIRONMENT

- This device has been designed according to the European Directive No. 2002/95/EC. This refers to the restriction of certain hazardous substances in electrical and electronic equipment (ROHS)
- This device has been designed in compliance with the European Directive No. 2002/96/EC concerning waste electrical equipment (WEEE).
- This picture informs you that this device should not be discarded with household waste.
- At end of life, this product must be returned to a collection point or returned to an authorized dealer. By doing so, you will help to protect the environment and human health.



## 4. INSTALLATION

### 4.1. IN CASE OF A STANDBY OF THE MACHINE (STANDBY = 2 MONTHS):

- The first thing to do is to test your machine in a lab.
- If the machine stop running for a long time, you could have scale in some places.
- More precisely in small area like the spray nozzle.

### 4.2. PROTECTIONS

- It is necessary to place before the machine:
  - A water shutoff valve.
  - An electrical protection standard, suitable for voltage and power consumption.

### 4.3. WATER SUPPLY

- Recommended operating pressure from 1.5 MPa to 6 MPa
- Water connection pin 3/8"
- The water supply pipes must resist to 145 Psi / 10 MPa

### 4.4. DRAIN

- Without pressure.
- **Spigot at the outlet of the machine and a pipe is supplied with the machine**
- Ensure a connection that causes no risk of fluid return, and ensure good drainage:
  - The drain pipe must be located lower than the machine.
  - Do not create a bend in the exhaust tube.

### 4.5. SUPPLYING VOLTAGE

According to the model:

- 230V – 50/60Hz Monofase
- 400V – 50/60Hz Trifase

#### 4.6. WATER SOFTENER

- When the mains water has a high hardness ( $>10^{\circ}\text{TH}$  ou  $>4^{\circ}\text{KH}$ ), it is recommended:
  - To use a water treatment
  - To regenerate regularly the filters.
  
- What is the **total Hardness of the water** ?
  - This is the amount of calcium and magnesium ions in the water.
  - These ions are partly responsible for limestone formation.
  - It is measured with the test strip provided with the machine.
  - The unit of measurement is the  $^{\circ}$  French ( $^{\circ}\text{TH}$ ) or the  $^{\circ}$  German ( $^{\circ}\text{dH}$ ).
  
- What is the **Karbonat Hardness of the water** ?
  - This is the amount of Carbonate Calcium ions and Carbonate Magnesium ions in the water.
  - These ions are completely responsible for limestone formation.
  - It is measured with chemical dropper testers.
  - The unit of measurement is  $^{\circ}$  Carbonate ( $^{\circ}\text{KH}$ )

There are 2 types of water treatments:

- Salt water softeners
  - They treat the total water hardness ( $^{\circ}\text{TH}$ )
  - By an exchange of sodium ions with calcium and magnesium ions.
  - They require periodic regeneration of the resins by the user.
  - To use when the water hardness is  $> \grave{a} 10^{\circ}\text{TH}$  ou  $> 5^{\circ}\text{GH}$
  
- Resins filters :
  - They treat the Carbonat hardness water ( $^{\circ}\text{KH}$ )
  - By fixing carbonate ions on the resins.
  - Often fitted with microfiltration and carbon filtration.
  - To use when the Carbonat Hardness is  $> \grave{a} 6^{\circ}\text{KH}$
  - Highly recommended by the manufacturer :
    - The machines are equipped with suitable protection in accordance with flowrate and the water encountered.
    - The changing cartridges is carried out by the technical service, at intervals to be determined

## 5. OPERATION

### 5.1. RECOMMANDATIONS

- Open the general water tap, if it is closed, then open the water shutoff valve dedicated to the machine.
- Do not put the supplying voltage at this moment.
- Verify the presence of water, by reading the pressure of the mains water inlet on the M2 manometer pump.

### 5.2. INITIAL FILLING

- Ensure that steam taps operating levers 'V' are open (up).
- Put the ON/OFF switch 'C' to position 1 (power on).
- The key board turn on.
- The boiler fills automatically, without heating.
- The machine start to heat automatically, only when the level probe is reached by the water
- A scrolling LED on keypads can inform the user about the status. (info display : « machine en chauffe »)
- Close the steam tap "V" and wait.
- When the scrolling leds stops : **The machine is ready to operate** (info display : « < 60°C CONTI ESPRESSO »)



### 5.3. FURTHER FILLINGS

- Further fillings will run automatically, according to the hot water needs.
- The water level in the boiler is controlled by the electronics, by the means of a level probe.



## 6. HOW TO USE THE MACHINE

### 6.1. OPERATING ELEMENTS

#### ➤ **STEAM FUNCTION**

Two steam taps levers « V » are provided to allow:

- The heating of liquids by spraying steam.
- The milk foam production to create Cappuccino or Macchiato.

The liquid to be heated should preferably be placed in a deep container.

The tip of the steam wand outlet must be immersed in the liquid, without touching the bottom of the container.

The steam may also be used to sterilise and warm glasses.

After each use and absolutely **after heating milk**, always clean the stainless steel steam nozzle and the outlet nozzles with a damp cloth, removing all traces present.

A rinsing of the steam lance inner holes is to be done by a short opening of the tap to release a jet of steam.

#### ➤ **HOT WATER FUNCTION**

A manual tap 'E' is provided for preparing tea, grog, etc.

Be careful, not to be burnt by the pressure water spray.

#### ➤ **FILTERS**

The machine is equipped with two types of filters: 1 cup and 2 cups.

Each filter is operating with its own holder-filter to produce respectively 1 cup or 2 cups of coffee.

Filters need to be unclogged and clean, so they need to be cleaned almost once a day with hot water, by being removed from the holder filters.

Take care to remove all residual traces of coffee and ensure proper cleanliness of perforations in the bottom of the filter.

#### ➤ **FILTER-HOLDER**

Never remove the filter-holder during operation of the group. The end of extraction is checkable with coffee spouts: they no longer have to eject liquid.

Be careful to always keep the filter-holder engaged in the group, emptied of coffee cake, to keep them warm.

In case of an extended stopping period, remove the filter-holder from the group, taking care to eject the used grounds remain in the filter-holder.

Tighten the filter-holder until to be in contact with the seal, exceeding a little bit. The sealing is guaranteed.

Do not unnecessarily try to crush the seal by tightening the filter at the maximum of your possibilities. It may damage the seal or age it prematurely.

To empty the coffee filters used, turn the filter holder upside-down and lightly tap it on the edge of a wooden box. Never strike it against metal or other hard objects.

#### ➤ **BUTTON TO CAPTIVATE MANUALLY THE COFFEE**

This button allows you to make coffee in the case where electronics is faulty.



➤ **MANOMETER M1 : BOILER PRESSURE**

The boiler pressure is adjusted in factory between 0,8 MPa (12 PSI) and 1 MPa (15 PSI). This value varies slightly around its nominal temperature, due to the PID system which controls the heating and limit the current consumption to its minimum.

NOTE: An over-heating thermostat will cut the heating, in case of an abnormal high temperature.

➤ **MANOMETER M2 : PUMP PRESSURE**

The pump pressure is adjusted at 9 MPa in the factory. Value which allows the best extraction of coffee flavors. A bypass system evacuates over-pressure.

NOTE: Simultaneous operation of all the groups can impact a little bit the pressure level.

Visualization of the presence of water network is done by consulting the gauge

**6.2.        HOW TO USE THE PROGRAMMED DOSES**

- Simply select one of the buttons available on each keypad to obtain the doses or the programmed drinks.
- The selected dose is shown by a blinking led on the keypad.
- The flow can be stopped by repressing:
  - The same button or
  - The STOP button (which is also the programming and continuous flow button).

## 7. PROGRAMMING OF COFFEE DOSAGE

### 7.1. PROGRAMMING PROCEDURES

Programming is done on the group 1 (left group), the 5 keys are defined as follows:

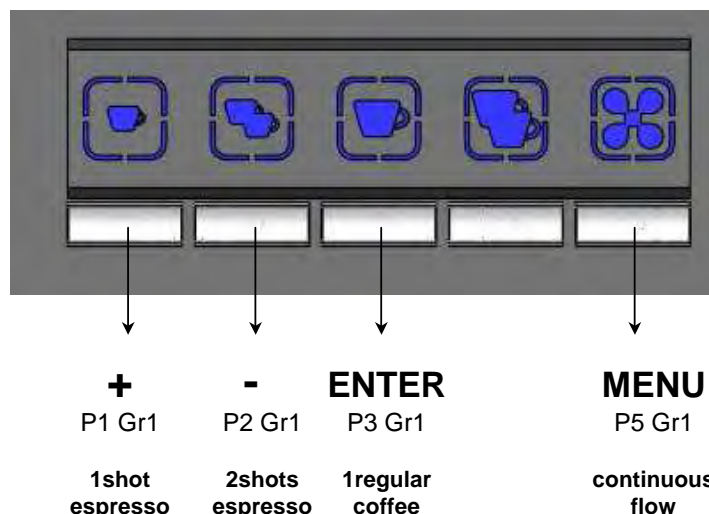

2 ways of programming are possible to set the coffee dose.

- Choose 1st group (on the left when the user is in front of the machine)
  - To program all groups at the same time with the same value.
  - The programmed key will have its equivalent key programmed identically on the others groups
- Choose the others groups separately, if the groups need to have different value.

#### Methodology:

- ☞ Put the ground coffee (1 dose or 2 doses according to the programmed key), in the suitable filter holder.
- ☞ Press the key n°5 "P5 Gr1" from the selected group during 10 seconds, until it's blinking.
- ☞ Release the key n°5 "P5 Gr1"
- ☞ Display shows "Press dose selection within 30s"
- ☞ The operation can start in a delay of 10 seconds. Otherwise it go back from the programming mode.
- ☞ Press the key to be programmed to start the flow, and press again when water quantity is correct. The value is directly registered.
- ☞ Then, continue programming the next key within 10 seconds, and so on for the other keys.
- ☞ You can use any coffee button after the message "Press dose selection within 30s" disappears

Note : On the factory, each machine undergoes a test protocol on which a program has already been completed, according to the following settings:

1 espresso = 2,5 cl / 2 espressos = 5 cl / 1 coffee = 4,5 cl / 2 coffee = 9 cl

## 8. RELATED FONCTIONS

### 8.1. ECO MODE SETTING

The evening or before a long period of inactivity, the economic mode of the machine allows the standby position.

The boiler is then maintained at a temperature of 60°C, which allows:

- saving energy when the temperature drop
- and during the day, as the setpoint temperature is low, this phase mobilizes little energy.

To activate the "ECO" mode, proceed as follows:

- hold the "P5 Gr1" key,
- and press "P3 Gr1"
- all lights will turn off to indicate the change in "ECO" mode,

- the display indicate



**ECO  
CONTI ESPRESSO**

- And the "L1 Gr1" led blinks slowly (0.2 sec ON / OFF 2.8 sec).

Output of the "ECO" mode allows the machine to return quickly to its normal functioning mode, without spending lot of energy.

To return to normal operation, proceed as follows:

- Press the button "P3 Gr1".
- All the LEDs light up to indicate the return to normal operation.
- The machine will heat up to reach the programmed temperature.

The display indicate



**117°  
CONTI ESPRESSO**

The machine will heat up to reach the programmed temperature.

## 8.2. AUTOMATIC CLEANNING OF COFFEE GROUP

The cleaning of coffee group is made group by group, preferably at the end of service, before the machine is stopped or put in "ECO" mode, using this specific function managed by the machine.

The procedure for cleaning coffee groups is as follows:

- Remove the filter-holder from the group and clean the seal with the supplied brush.
- Insert blind filter (provided with the machine) in the filter-holder.
- Put a detergent tablet (CONTI brand code: 466662) in the blind filter, and engage the filter-holder in the group.
- Keep pressing key "P5 Gr1", then press the key "P1 Gr1".
- The cleaning process starts automatically, with some ON/OFF cycles. The purpose is to dissolve the tablet, and release the cleaning agent on the coffee group circuit and on the coffee valve.

- the display indicate

**Cleaning Gr x  
In progress**

- When the cleaning cycle is finished, and the group is available again.
- Repeat this operating mode on each group.

The cleaning cycle can be interrupted, pushing any key of the concerned group. But, you will lost the following steps, and will compromise the cleaning efficiency.

It is possible to perform an automatic washing cycle for each group independently

## 8.3. RESETTING DATA

If necessary, it is possible to re-configure the machine with data by default.

The procedure is as follows:

- Turn off the power supply of the machine.
- Keep pressing simultaneously the keys "P1 Gr1" + "P3 Gr1"+"P5 Gr1"
- Turn the machine on.

- the display indicate

**Preset value  
completed**

To return to normal operation, turn off and on the machine.

## 9. PROGRAMMING PARAMETERS OF TECHNICAL MENU:

Machine must be in Eco mode (keep pressing MENU button and press ENTER to be in ECO mode).

### 9.1. FLOW CHART TECHNICAL MENU

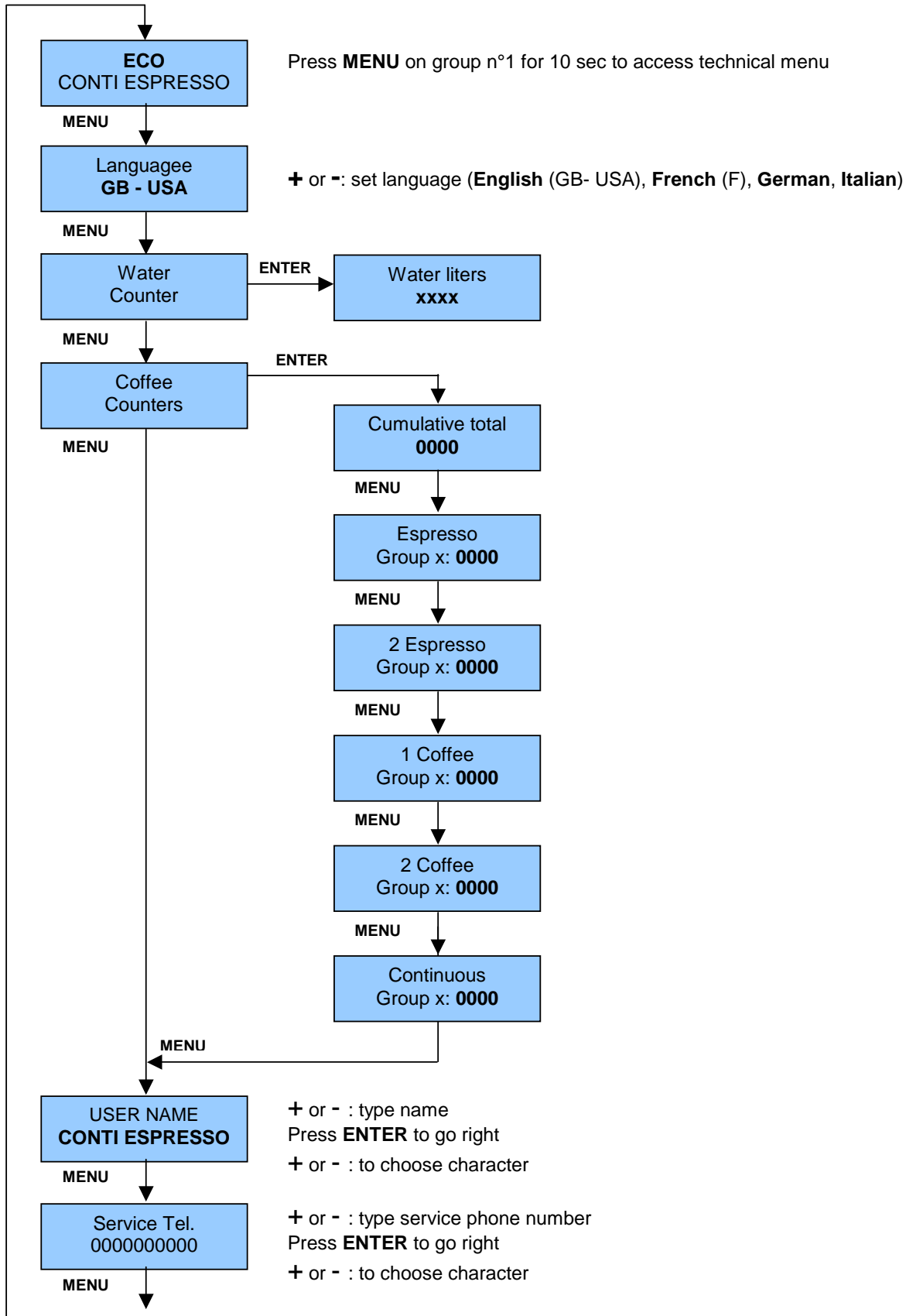

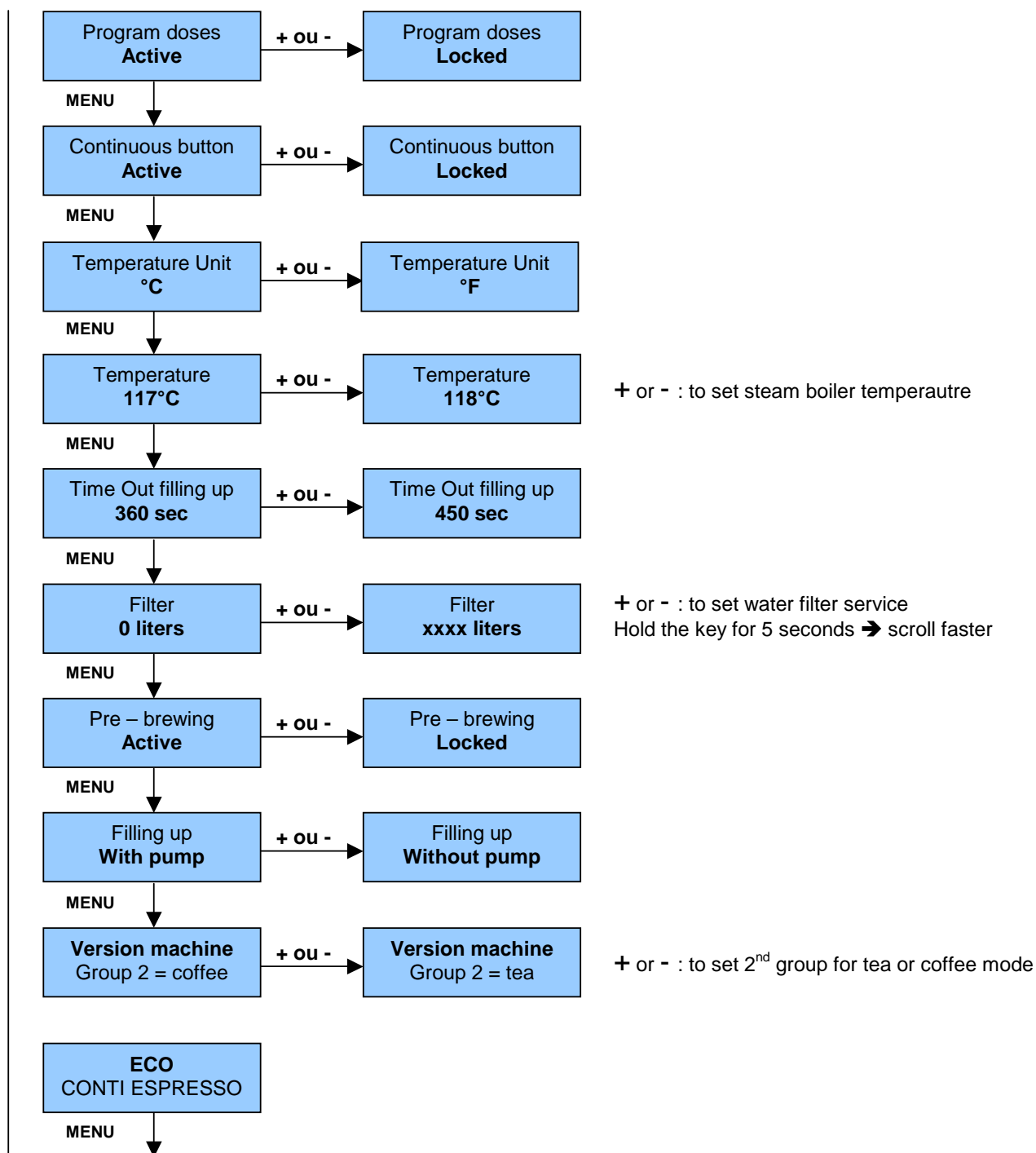

## 9.2. EXPLANATION FOR THE PROGRAMMING STEPS OF THE TECHNICAL MENU:

### ➤ **Language:**

There are 4 languages available : ENGLISH (GB-USA) – FRENCH (F) – GERMAN (G) – ITALIAN (I).

### ➤ **Water counter:**

This menu is dedicated to the water softeners system.

This step allows to see the quantity of water consumed (in liter, from 0 to 9999 liters) by the machine from the last water softener installation.

The quantity of consumed water is made of:  
Coffee water going through the flowmeter.  
The water entering in the boiler.

To escape, you need to press MENU.

### ➤ **Coffee counters:**

Allows partial reading of doses distributed cafes.

Press ENTER to access the menu Counters.

Press MENU to see each key, the display shows:

- ☞ Cumulative total cycles number (service purpose).
- ☞ espresso number (1 small cup) on group 1, 2 and 3
- ☞ 2 espresso number (2 small cups) on group 1, 2 and 3
- ☞ coffee number (1 large cup) on group 1, 2 and 3
- ☞ 2 coffees (2 large cups) on group 1, 2 and 3

NB:

- The counter goes up to 65535 for each button. Then it restarts from 0.
- A distribution is accounted for 1 time for keys " P1 Grx " or "P3 Grx" or "P5 Grx" and 2 times for the keys " P2 Grx " and "P4 Grx" when you press a key.

### ➤ **Explanation about counters reset:**

Coffee counter reset: when the display shows «Cumulative total», press "P4 Gr1" for 3 seconds, the display shows then « Total Reset ».

Only the counters of each key is reset. The total counters of products is not reseted.



➤ **Name:**

Type name to be showed on the display.



CONTI ESPRESSO

Press ENTER to go right  
To change character press + or –  
To finish press MENU

➤ **Service phone number:**

Shown on the display together with an alarm message.

Press ENTER to go right  
To change number press + or –  
To finish press MENU

➤ **Dose programming access:**

Dose programming authorization access.  
Change with + or -.

➤ **Continual dose access:**

Continual dose authorization access.  
Change with + or -.

➤ **Temperature unit choice:**

°C or °F  
All values are automatically converted.

➤ **Steam boiler temperature adjustment:**

Adjustment range: 80 to 125 °C (176 °F ... 257°F)

We advise 117°C .

To change temperature press + or –  
To exit, press MENU, or wait 30 seconds.

➤ **Filling up Time out adjustment:**

Adjust maximum opening time of the inlet solenoid valve ; beyond this time, machine stops and an alarm message is displayed in order to indicate that no water goes in the boiler.

Adjust time with + or – ( up to 360 sec max)  
To exit, press MENU, or wait 30 seconds.

➤ **Water Filter:**

Adjust water volume for the water softener maintenance (0 to 9999 litres)

Press + or – to adjust. (Hold the key for 5 seconds → scroll faster)  
To exit, press MENU, or wait 30 seconds.

When water volume is reached, display shows:



Change  
H2O filter

Procedure to reset the water counter :

When the programmed amount of water has been consumed by the machine, the message "Change Filter" and the service phone number to contact, appears on the display

This message prompts the user to change the cartridge system of water treatment but does not forbid the distribution of products.

Once the cartridge has been changed, you have to clear the message:

- Switch off the machine (the button ON / OFF).
- Keep pressing the keys "P3 Gr1" and "P4 Gr1" (on left group).
- Turn on the machine (the button ON / OFF), the display shows:

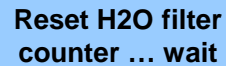

Reset H2O filter  
counter ... wait

The count resumed at zero.

➤ **Pre Brewing utilisation:**

Enables or disables pre-brewing on the 2 keys espresso.  
Change with + or -.

➤ **Filling the boiler:**

Allows to choose the filling of the boiler :  
With pump (if the machine works with tank)  
Without pump (if the machine is connected on the network)

## 10. SUMMARY OF THE PROCEDURE RESETTING THE COUNTERS

### 10.1. HOW TO RESET THE COFFEE COUNTER

Put the machine in the "ECO" mode with the key "P5Gr1" and "P3Gr1"  
Enter in the programming mode, pressing during 10 seconds the "continuous" key (P5Gr1).  
Repeat to press this "P5Gr1" key several time in order to reach "Coffee counters" menu.  
Press the key "P3Gr1" to enter in this menu: the display shows «Cumulative total».

Press the key "P4 Gr1" for 3 seconds,  
The display shows then « Total Reset ».

Only the counters of each key is reseted. The total counters of products is not reseted.

### 10.2. RESETTING DATA

If necessary, it is possible to re-configure the machine with data by default.

The procedure is as follows:

- Turn off the power supply of the machine.
- Keep pressing simultaneously the keys "P1 Gr1" + "P3 Gr1"+"P5 Gr1"
- Turn the machine on.
- the display indicate

**Preset value  
completed**

To return to normal operation, turn off and on the machine.

### 10.3. PROCEDURE TO RESET THE WATER COUNTER :

When the programmed amount of water has been consumed by the machine, the message "Change Filter" and the service phone number to contact, appears on the display

This message prompts the user to change the cartridge system of water treatment but does not forbid the distribution of products.

Once the cartridge has been changed, you have to clear the message:

- Switch off the machine (the button ON / OFF).
- Keep pressing the keys "P3 Gr1" and "P4 Gr1" (on left group).
- Turn on the machine (the button ON / OFF), the display shows:

**Reset H2O filter  
counter ... wait**

The count resumed at zero.

## 11. DESCRIPTION OF ALARMS

These alarms occur when there is a defect on the machine, they are indicated differently depending on the nature of the defect.

### ➤ ALARM TIME OUT 1ST FILLING

If the electronic does not receive information from the SN level probe for more than 360 seconds (at the 1st filling), the LED "L2" & "L3" of all groups will flash to indicate failure.

**Alarm Time Out  
Filling**

### ➤ ALARM FLOWMETER

If, during the distribution of coffee, the mother board does not receive pulses from a flowmeter for more than 4 seconds, all LEDs of the concerned group start flashing to indicate failure. After 45 seconds, the machine automatically stops the solenoid valve of the concerned coffee group and the pump also.

**Alarm flowmeter  
Group x**

### ➤ ALARM TEMPERATURE SENSOR DISCONNECTED

If the mother board does not receive information from the temperature sensor for more than 3 seconds, the electronics automatically cut off the solid state relay and leds "L1"& "L4" from all groups will flash to indicate default.

**Temperature probe  
not connected**

### ➤ OVER TEMPERATURE ALARM

If the electronics detects a temperature  $> 140\text{ }^{\circ}\text{C}$  for more than 5 seconds in the boiler, the LEDs "L3" of all groups will flash at the same time and the management of the heating is stopped automatically. The alarm is removed when the temperature drops below  $125\text{ }^{\circ}\text{C}$ .

**Over temperature  
steam boiler**

### ➤ ALARM CLEANING GROUP

After making 250 distributions on a same group, the display shows

**Clean please  
Gr: X**

The machine is still usable but the message does not disappear until the cleaning has not been made.

To start the cleaning procedure, see chapter: related fonctions.

## 12. HOW TO MAKE THE PERFECT COFFEE

Obtaining a good cup of coffee is the result of certain conditions: the 5 golden rules of perfect espresso:

MIX / GRINDER / MACHINE / HAND / and MAINTENANCE.

### ➤ The Mix:

- The type of coffee is very important. It can be distinguished 2 mains qualities:

- ARABICA:

It gives a fragrant taste, sweet, chocolaty, slightly acid, with a pleasant bitterness. The coffee color is hazelnut cream

- ROBUSTA:

It gives a less fragrant taste, rough, astringent and significantly more bitter. The caffeine content is about twice. The coffee color is greyish brown.

- The roaster has a great importance on the quality of each coffee (choice of grain, selection processes, roasting, packaging processes, ...).

### ➤ The Grinder:

The grinder and the grind adjustment are essential:

- The coffee grinder:  
grinding capacity of the coffee beans must be commensurate with the needs of the user. Indeed, excessive use causes overheating of the mill wheels and thus a rapid realignment of the mill.
- The grind adjustment:  
setting the mill to choose the fineness of the grind and the right dose required to achieve optimum coffee. The dose should be adjusted to 7 grams for a cup; finesse should allow a flow time of coffee in the cup about 20 - 25 seconds: this time ensures the dissemination of flavors in the cup.

### ➤ The Machine:

It must be well adjusted and kept very clean !

- Pump Pressure limited to 9 MPa.
- Water temperature out of the shower must be between 86 °C and 92 ° C
- Correct programming doses.
- Daily cleaning performed every evening.
- Ensure that the water treatment is operating well.
- Follow the maintenance recommendations

➤ **The Hand:**

Skill of the operator: He must of course control the above three factors, but also:

- He know how to maintain coffee.
  - For exemple, a milling do not remain in the open air.
  - He know that coffee bean loses 1% of its flavor by day ground coffee, it loses 45% day.
  - Therefore he avoid grinding too much coffee at once, or keep in drawers.
- The filter-holder need to be warm, so it must be maintained on the group.
- The cups need to be warm, about 40 ° C. They are therefore placed on the cup warmer.
- He damp correctly the coffee in the filter-holder.
- He ensure proper regularity milling for constant quality coffees.

➤ **The Maintenance**

This is the necessary condition for the success of a good coffee:

At the end of each daily period of activity, it is strongly recommended to perform a cleaning operation on each group coffee.

Double impact:

- Improve coffee quality by eliminating oxidized fats
- Ensure the proper operation of the coffee group.

## 13. MAINTENANCE OF MACHINES

### ➤ DAILY MAINTENANCE

- Clean the hot water outlet and the steam outlets with a scouring pad:
  - o Use a needle to keep the diffuser outlets unclogged.
  - o Then purge by opening the tap a few seconds.
- Clean the drip tray and the basin, removing them from the machine.
- Remove the filter-holder from the groups and clean the seal injection filter-holder with the brush.
- Use the automatic process cleaning:
  - o Insert blind filter in the filter holder and place the CONTI cleaning tablet code n°466662
  - o Engage this filter-holder on the group to be cleaned
  - o Simultaneously press the 5th (continuous) and the first key (1 espresso)
  - o The automatic cleaning process of the group is started
  - o Repeat this procedure on each group.
- Brush the filters in water containing detergent:
  - o In order to unclog the holes
  - o Never use a needle or a flame.

### ➤ HALF YEAR MAINTENANCE

- A kit n° 470891, for the following operation is available for sale.
- For each group:
  - o Remove the sprinkler, diffuser, and seal gasket.
  - o Scrub the gasket groove and the supplying hole on the group head.
  - o Clean the diffuser. Clear all the holes with a needle.
  - o Reassemble the diffuser on the group head
  - o Place NEW Filter gasket, and NEW sprinkler.
- Remove and clean the level sensor (limestone deposit).



➤ **ANNUAL MAINTENANCE**

- A kit n° 470892, for the following operation is available for sale.
- Change the pump inlet filter (No. 411861)
- On the boiler:
  - o Change vacuum valve (No. 408898)
  - o Change the safety valve (No. 404326)
- On the inlet bloc valves:
  - o Change the filter (No. 470199)
  - o Replace the gasket (No. 219100) of 2 non-return valves
  - o Remove and clean the gasket limiter 12 Bars
  - o Clean the nucleus of the solenoid inlet water boiler
- On the coffee groups
  - o Change the O-ring nozzle (No. 403457) and the filter nozzle (No. 403458)
  - o Clean the 3rd way and the nucleus of the solenoid coffee valves
- On the 2 steam taps and the hot water tap
  - o Change the 2 O-rings (No. 403457)
  - o Change the 2 gasket (No. 407502)
- On the 2 "steam" output and on the "hot water" output
  - o Change the O-ring (No. 061200)
  - o Change the O-ring (No. 055300)
- For water quality issues, it is recommended to completely drain the boiler.

➤ **BIENNIAL MAINTENANCE**

- A kit n° 470892, for the following operation is available for sale.
- Change the pump inlet filter (No. 411861)
- On the boiler:
  - o Change vacuum valve (No. 408898)
  - o Change the safety valve (No. 404326)
- On the inlet bloc valves:
  - o Change the filter (No. 470199)
  - o Replace the gasket (No. 219100) of 2 non-return valves
  - o Remove and clean the gasket limiter 12 Bars
  - o Change the inlet boiler valve (No. 470161) + 2 PTFE gasket (No. 407500)
- On the coffee group:
  - o **Remove all the parts and uncork all the holes in the group head.**
  - o Change the O-ring nozzle (No. 403457)
  - o Change the filter nozzle (No. 403458)
  - o Change the solenoid coffee (No. 407329) + 2 PTFE gasket (No. 407500)
- On the 2 steam taps and hot water tap:
  - o Change the 2 O-rings (No. 403457)
  - o Change the 2 gasket (No. 407502)
- On the rotary lever:
  - o Change the damper O-ring (n° 055200)
- On the 2 "steam" output and on the "hot water" output:
  - o Change the O-ring (No. 061200)
  - o Change the O-ring (No. 055300)
  - o Change the washer (No. 401320)
  - o Change the O-ring of steam nozzles (No. 055400)
- Change the silicone tubes evacuation 3-way valves cafes (No. 405621)

## 14. ELECTRONIC DIAGRAM

### 14.1. DESIGNATION OF USEFUL CODES

REF.	DESIGNATIONS	DESIGNATION
CE	Carte électronique	<i>Electronic controller</i>
CN	Connecteur tableau	<i>Panels connector</i>
CV	Compteur volumétrique	<i>Flow meter</i>
EE	EV entrée eau	<i>Solenoid valve water feeding</i>
EVG	EV de groupe	<i>Group solenoid valve</i>
MP	Motopompe	<i>Motor/pump</i>
RC	Résistance chauffage	<i>Immersion heater</i>
SSR	Relais statique 12Vdc – 230Vac 25A	<i>Solid state relay 12Vdc – 230Vac 25A</i>
ST	Sonde de température	<i>Temperatur sensor</i>
TS	Thermostat de surchauffe	<i>Overheating thermostat</i>

	CODE COULEUR FILS	CABLE COLOUR CODE
1	marron	<i>Brown</i>
2	rouge	<i>Red</i>
3	orange	<i>orange</i>
4	jaune	<i>Yellow</i>
5	vert	<i>Green</i>
6	bleu	<i>Blue</i>
6f	bleu foncé	<i>Blue dark</i>
7	violet	<i>violet</i>
8	gris	<i>Grey</i>
9	blanc	<i>White</i>
0	noir	<i>black</i>

## 14.2. ELECTRICAL HEATING CIRCUIT

FOR CC100 2G (3600W) 230V 50/60HZ

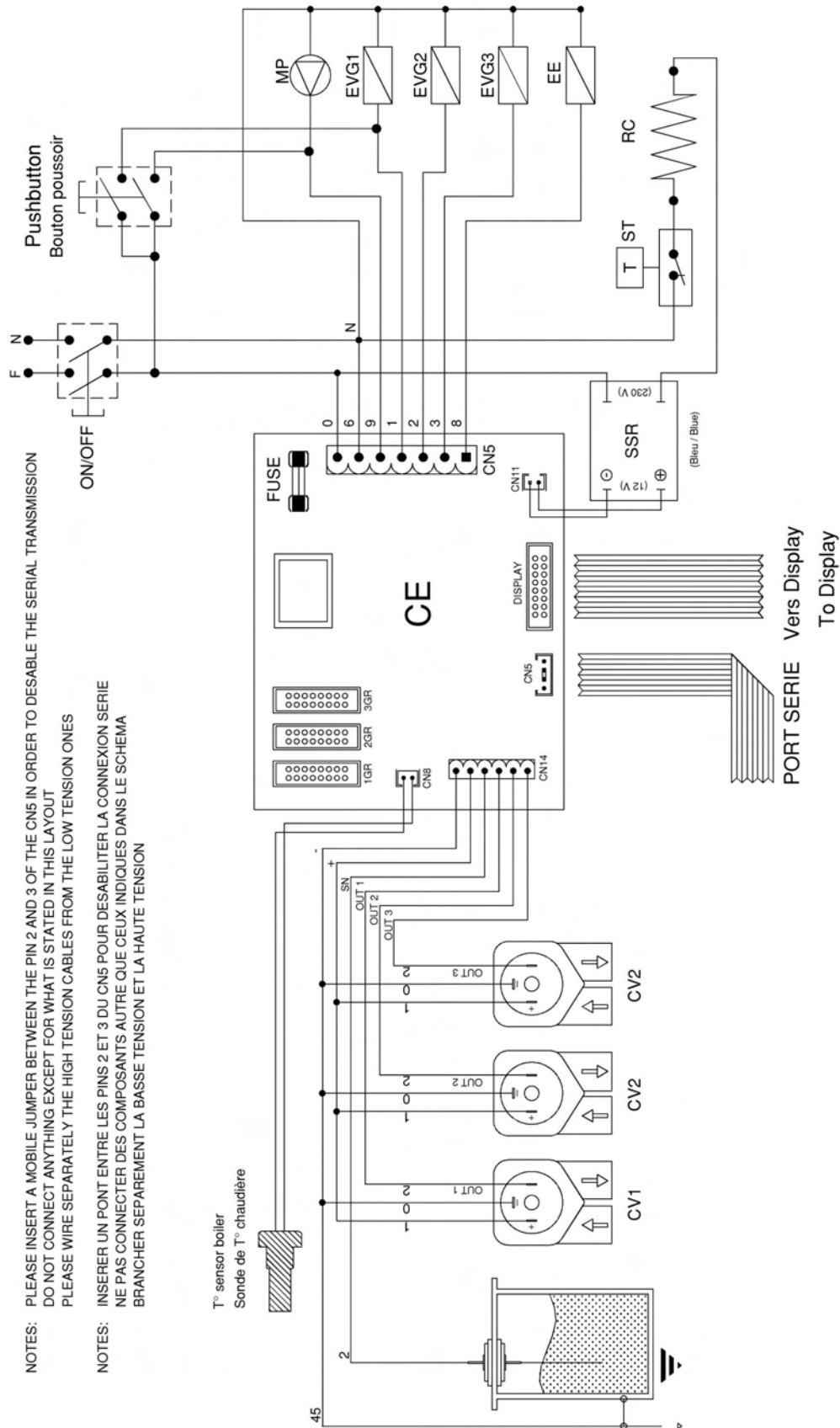

### 14.3. ELECTRICAL HEATING CIRCUIT

ELECTRICAL HEATING CIRCUIT for CC103 monophasé  
230 V (50/60Hz) for 4700 W

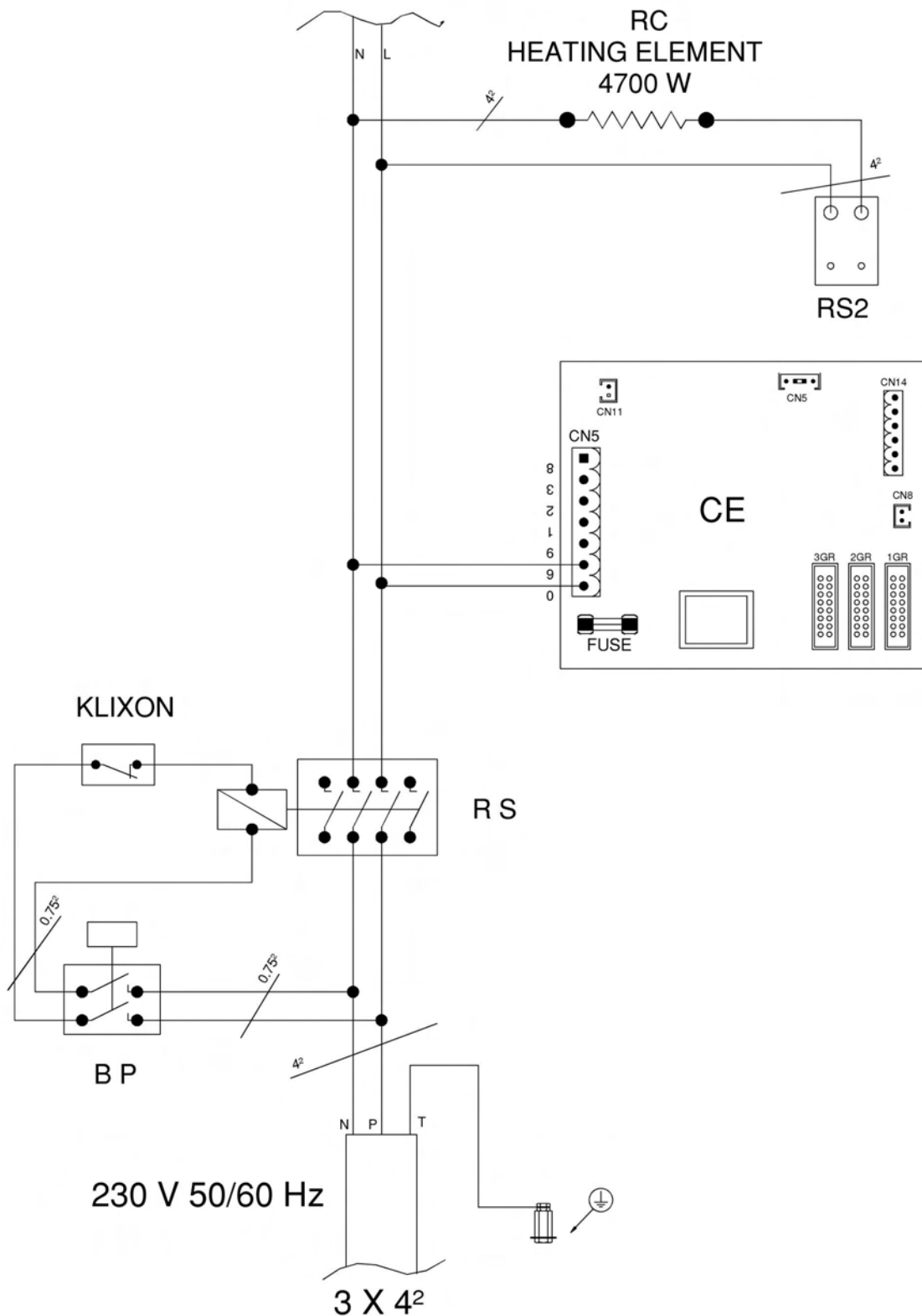

## 14.4. ELECTRICAL HEATING CIRCUIT

For CC100 3G (6000W) 400V 50/60Hz trifase

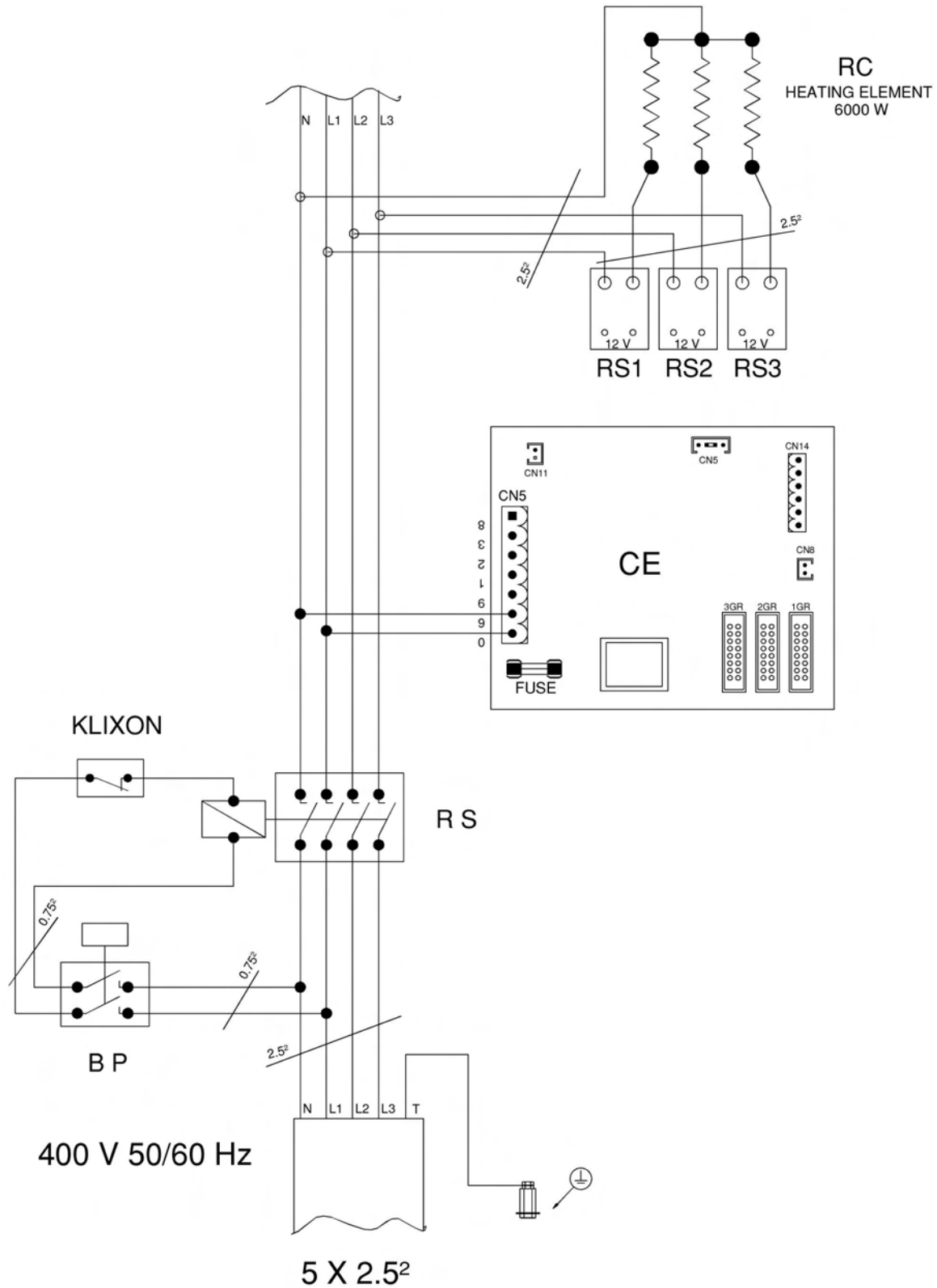

## 15. HYDRAULIC SCHEMA

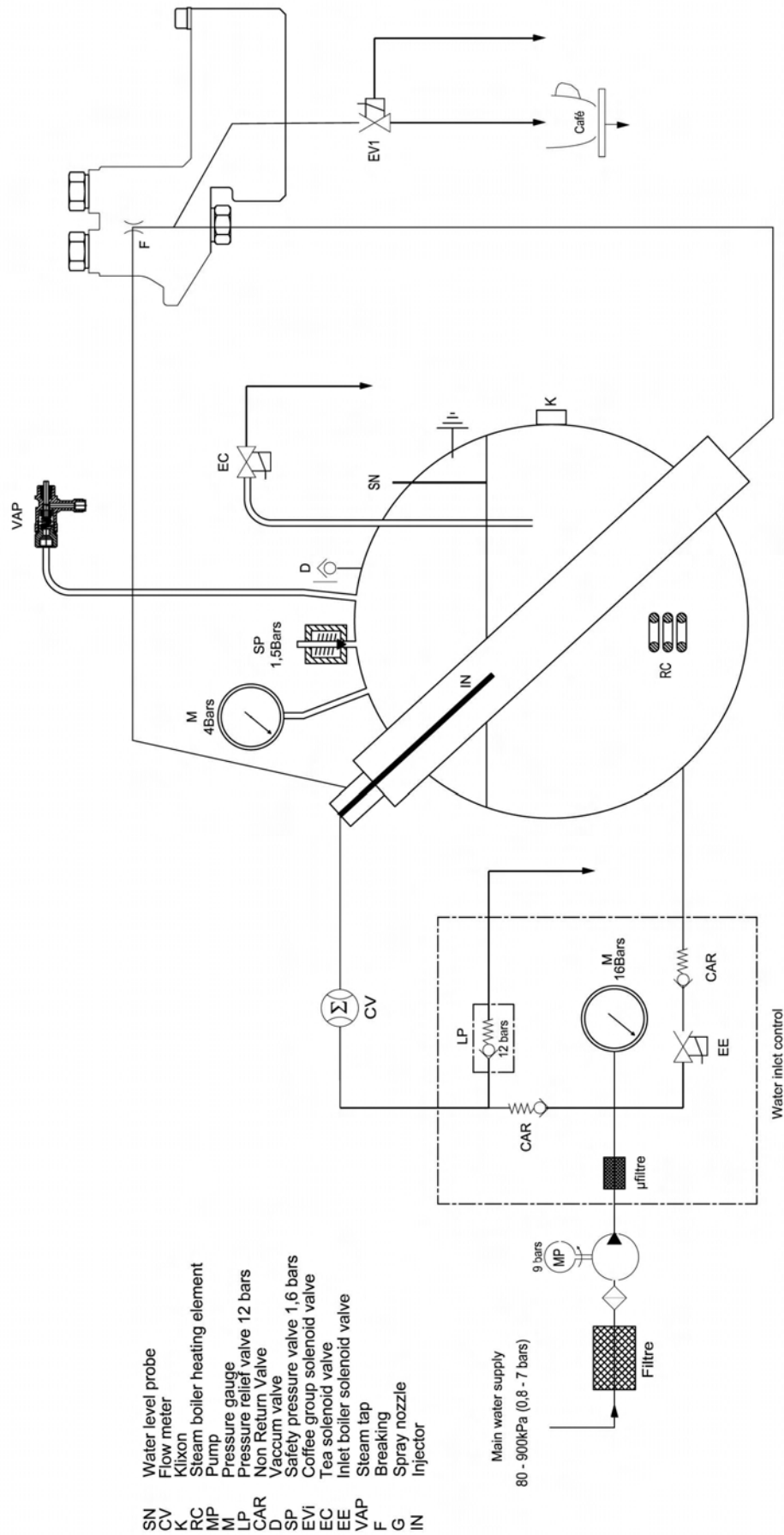



## 16. OPTION AVAILABLE

### 16.1. SOLO KIT

In case of insufficient pressure on the water system, or if the water supply is non-existent, you must use separate water tanks.

The machine must operate in SOLO mode:

- The filling up must be parametered "WITH PUMP" (P1 + P4)
- The machine draws its water from the bucket provided.

We offer for that a solo kit No. 411618 (order separately)

This kit consists of the following elements:

- 1 corrugated input to connect at the inlet of the machine (409195)
- 1 hose to connect to the corrugated input (464419)
- 1 "strainer + non return valve" to connect to the other side of the hose (409630+406986)

The role of the strainer is to ensure that the pump remains primed again.  
The role of the strainer is to ensure that the pump remains primed again.

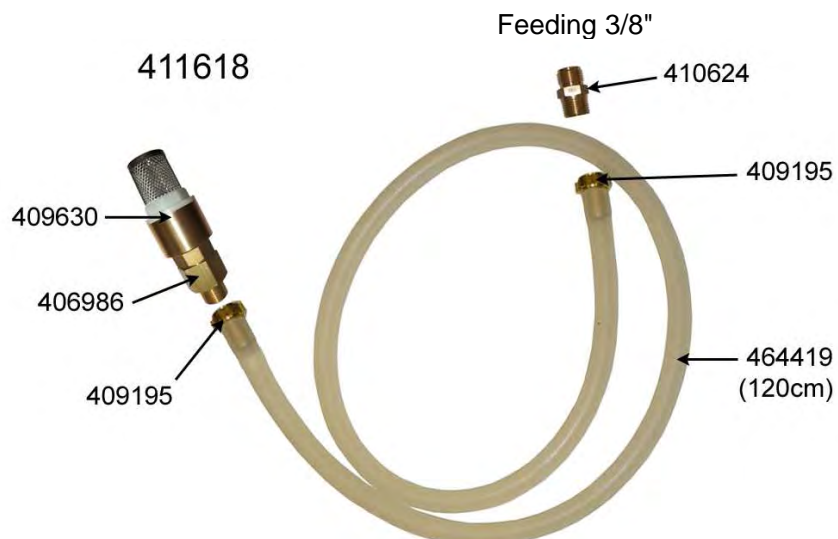

It is compulsory to fill up manually the silicone pipe with water before first starting the machine for the pump to prime properly, without risk of deterioration.



# **CONTI**

— E S P R E S S O M A C H I N E —



web

**La Ruche - 1, Avenue Albert II - B.P.119 - MC 98007 MONACO Cedex**  
**Tél.: (377) 93 10 43 43 Fax : (377) 93 10 43 44**  
**[http ://www.conti-espresso.com](http://www.conti-espresso.com) [http ://www.conti-spareparts.com](http://www.conti-spareparts.com)**  
**E-mail:tech@conti-espresso.com**