

JL-JLU-JT 2018 - PRESENT EZFREEDOM FLIP- TOP

EZTRUNK™ ASSEMBLY

— MANUAL —

#1918 0061 #1918 0461 #1920 0462

MAKE IT EZ

**Print the latest manual &
Watch the EZTRUNK Video**



**Scan QR CODE for Video &
PDF MANUALS**



**JL - JLU - JT
EZFREEDOM FLIP- TOP Hinge**

Customer Service

Any question? WE ARE HERE TO HELP!

Text or Call 203-901-0055 / Call 203-591-9060









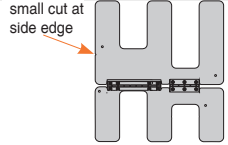
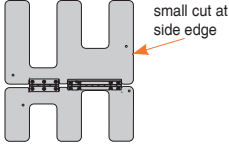
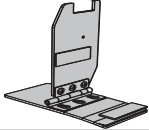
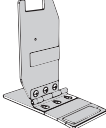
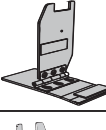

EMAIL US: SERVICE@EZTRUNK.NET

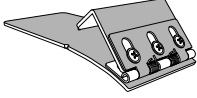
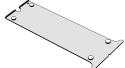
7 days a week 8:30 am EST

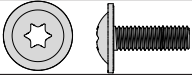
WE CAN HELP YOU!

PO# :

Please read instructions fully before beginning assembly

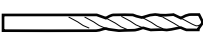
NO	Illustration	Description	Part#	JL QTY. #1918 0061	JLU QTY. #1918 0461	JT QTY. #1920 0462
1		Driver / Left Freedom Top Hinge	1918061D	1	1	1
2		Passenger / Freedom Top Right Hinge	1918061P	1	1	1
3		JL Lock Kit - Drive	191806101	1	\	\
4		JL Lock Kit - Passenger	191806102	1	\	\
5		JLU Lock Kit - Drive	191806103	\	1	\
6		JLU Lock Kit - Passenger	191806104	\	1	\
7		JT Lock Kit	191806105	\	\	2
8		Alignment Template	191806106-90	1	1	1
9		Rubber Pads	25250301	6	6	6
10		Adhesion Promoter	20	8	8	8
11		Short Bolt for Hardtop	061802	10	10	10
12		Lock Nut M6	10062	10+1 extra	10+1 extra	10+1 extra
13		Plastic Washer	06012	10+1 extra	10+1 extra	10+1 extra
14		Metal Washer	16012	10+1 extra	10+1 extra	10+1 extra
15		#10 & #13 Wrench	#10	1	1	1
16		Star Wrench-T30	60030	1	1	1
17		Drill Bit	#6	1	1	1

RECOMMENDED TOOLS

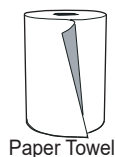
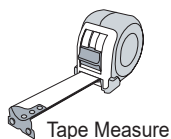
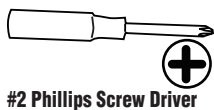

WARNING

EZFreedom Flip Top Hinge is designed to be installed on a roof with a factory finish, the product has not been tested on after-market finishes. The product warranty is void if the EZFreedom Flip Top Hinge is installed on a roof with any modifications or changes to the finish. Wash and dry roof prior to installation concentrating on the hinge location area. Ambient temperature should be at least **70F** for proper adhesion of the EZFreedom Flip Top Hinge. Please allow the Freedom Top Hinge to cure 24 hours before use.

WARNING This product is intended to provide added "off-road" convenience and utility to your vehicle. This product is not intended to provide occupant containment or protection in the event of an accident or rollover. Further, "on road" use may involve increased risk of serious injury in the event of side-impact accidents. To reduce risk from these types of injuries: Always wear seat belt and shoulder harness for all vehicle occupants. Keep arms and body inside vehicle. Drive safely, read and understand all manufacturers warnings and product instructions before installation. Periodically check and adjust all latches and fasteners. Failure to do so could result in the doors not latching securely.

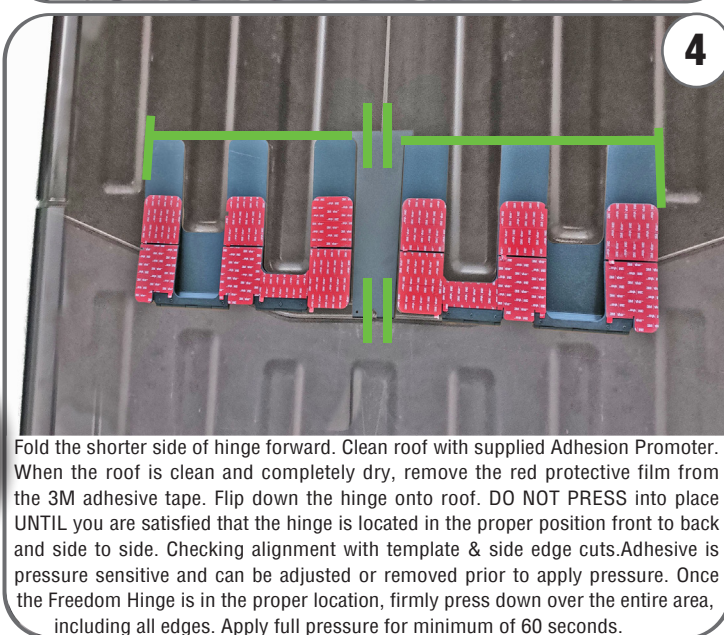
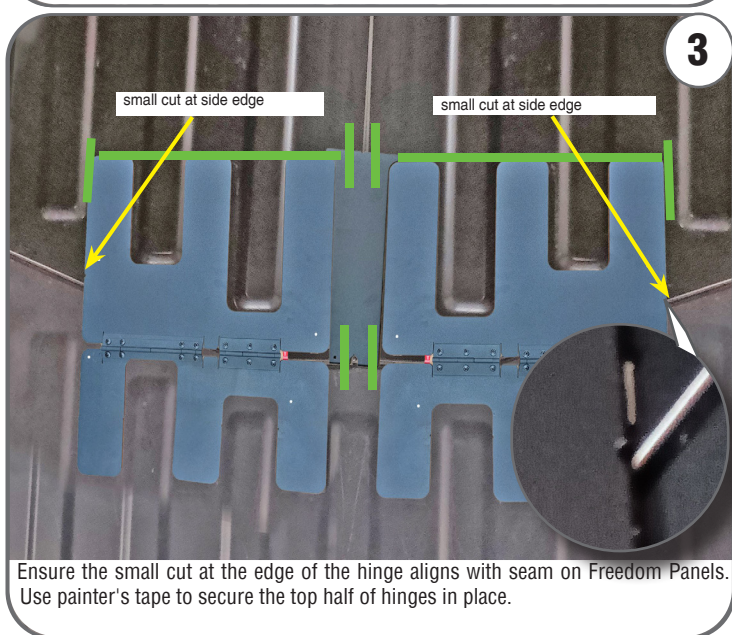
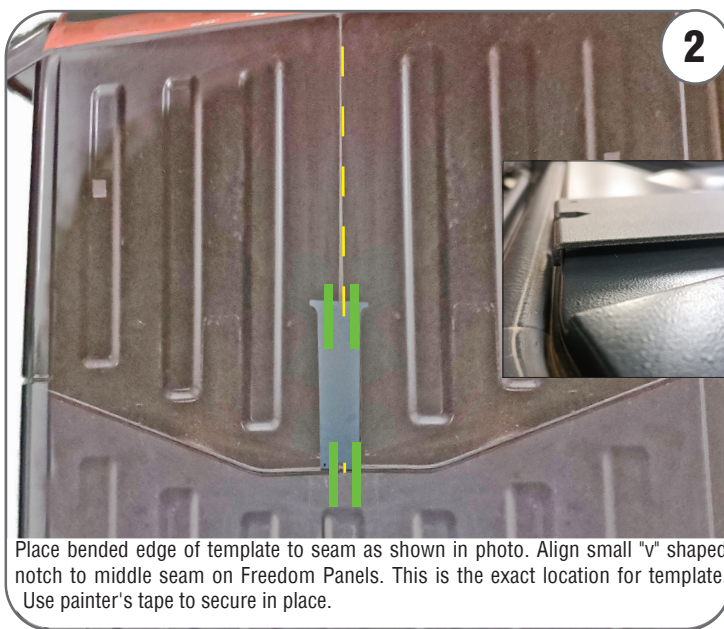
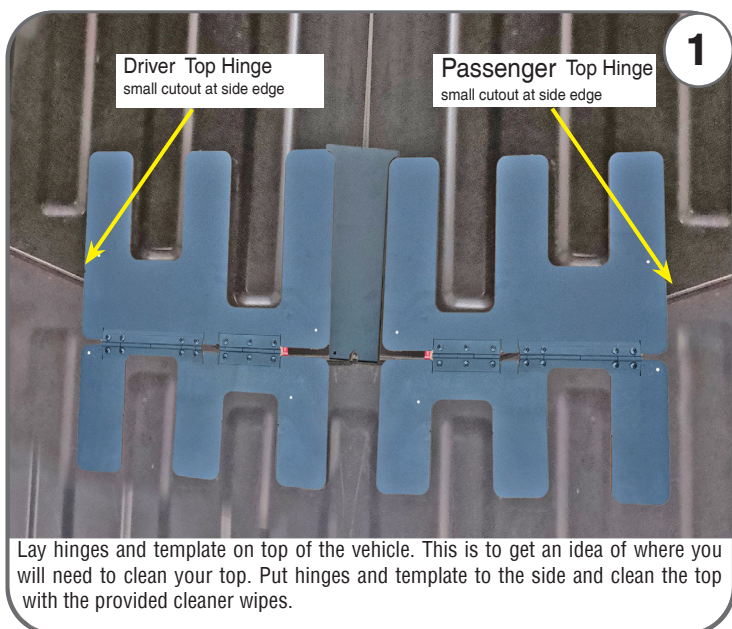

BEFORE BEGINNING, SEE THE ASSEMBLY INSTRUCTION VIDEO ON EZTRUNK.NET

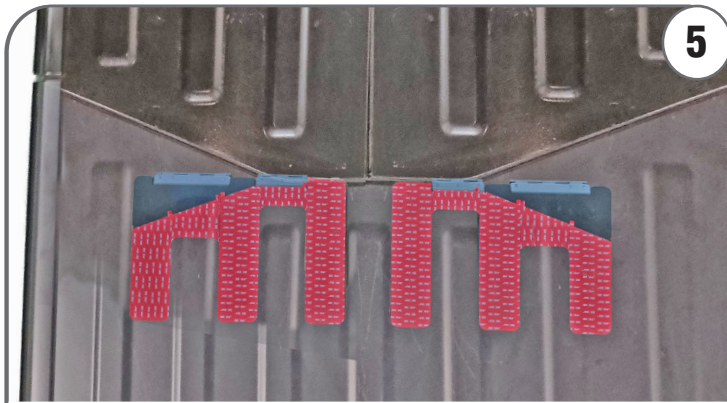

5

Repeat the same steps for the Longer-Top Half of Freedom Hinge. Fold the hinge forward. Clean roof with supplied Adhesion Promoter. When the roof is clean and completely dry, remove the red protective film from the 3M adhesive tape. Flip down the hinge onto roof. DO NOT PRESS into place UNTIL you are satisfied that the hinge is located in the proper position front to back and side to side. Checking alignment with template & side edge cuts. Adhesive is pressure sensitive and can be adjusted or removed prior to apply pressure. Once the Freedom Hinge is in the proper location, firmly press down over the entire area, including all edges. Apply full pressure for minimum of 60 seconds.

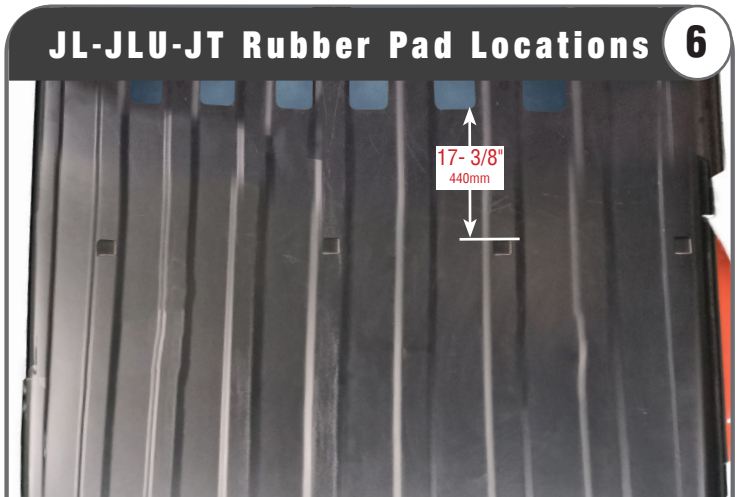

6

Place the rubber pads approximately 17-3/8" from short end of hinges, mark location with painter's tape. Clean this area with supplied Adhesion Promoter. When the roof is clean and completely dry, remove the red protective film from the 3M adhesive tape pads. Attach rubber pads in the proper location, firmly press down over the entire area, including all edges. Apply full pressure for minimum of 60 seconds.



7

Place the Lock Kit approximately 24 1/4" from short end of hinges, mark location with painter's tape. Clean this area with supplied Adhesion Promoter. When the roof is clean and completely dry, remove the red protective film from the 3M adhesive tape pads. Attach rubber pads in the proper location, firmly press down over the entire area, including all edges. Apply full pressure for minimum of 60 seconds.



8

Double Check the Lock Kit location first. Fold the freedom top backward and make sure the freedom top latch lock in slot from Lock Kit. Clean roof with supplied Adhesion Promoter bags. When the roof is clean and dry (around 5 mins). Remove the red protective cover from the adhesive tape. Place the Lock Kit to roof. Firmly press down over the Lock Kit for at least 60 seconds.



9

You can adjust the Lock Kit by those screws if necessary. Lock the freedom top by these kit when freedom top folded.

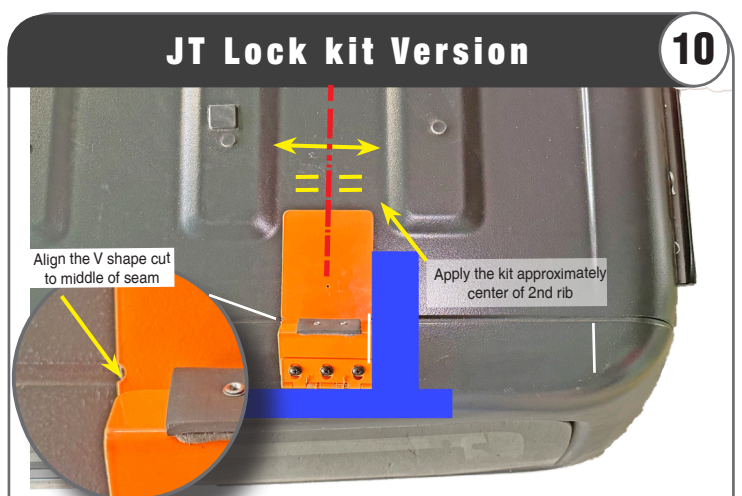

10

Place painter's tape as image show on driver and passenger side. Clean roof with supplied Adhesion Promoter bags. When the roof is clean and dry (around 5 mins). Remove the red protective cover from the adhesive tape. Place the Lock Kit to roof. Firmly press down over the Lock Kit for at least 60 seconds.

JT Lock kit Version

11

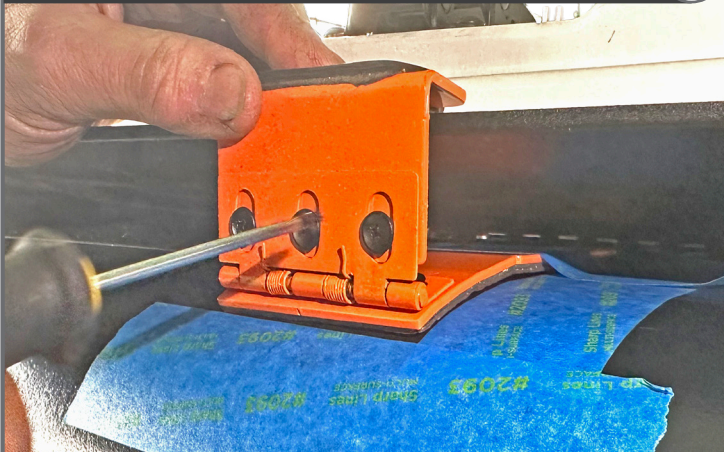

You can adjust the Lock Kit by those screws if necessary.

Extra Security Bolt on JT Lock Kit

12

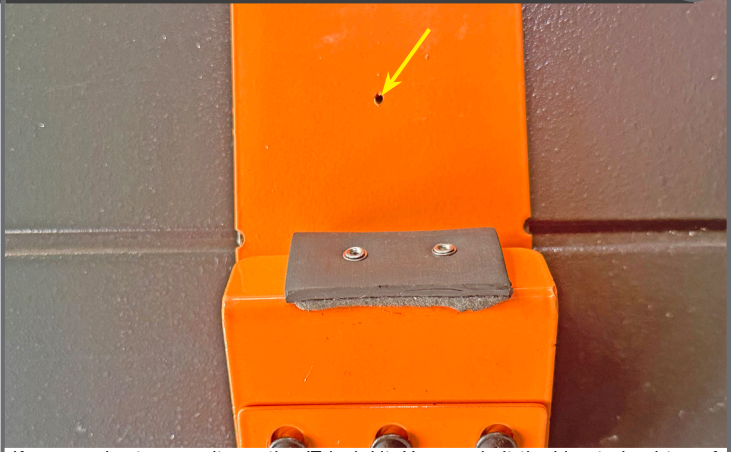

If you need extra security on the JT lock kit. You can bolt the hing to hard top of vehicle.Ensure the hinge in functional. Use a supplied drill bit to drill through hinge and hardtop of vehicle. there are (1) small pilot holes on each lock kit. keep the drill straight when drill the hardtop.

Extra Security Bolt version

13

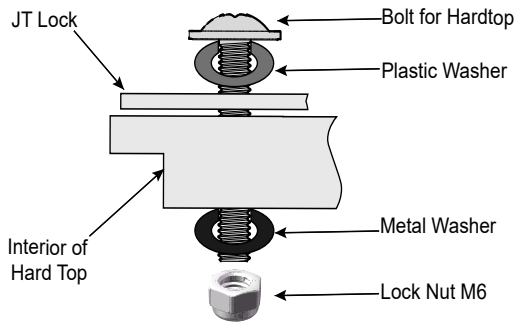

Extra Security Bolt version

14

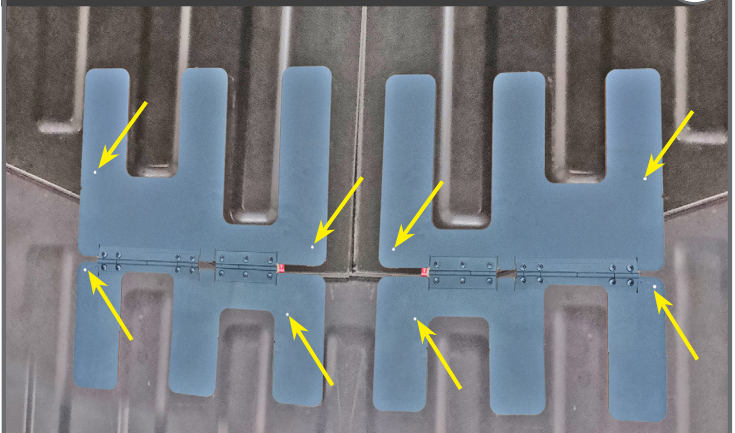

If you need extra security on the hing. You can bolt the hing to hard top of vehicle. Ensure the hinge in functional. Use a supplied drill bit to drill through hinge and hardtop of vehicle. there are (4) small pilot holes on each hinge, holes location marks similar as figure. keep the drill straight when drill the hardtop.

Extra Security Bolt version

15

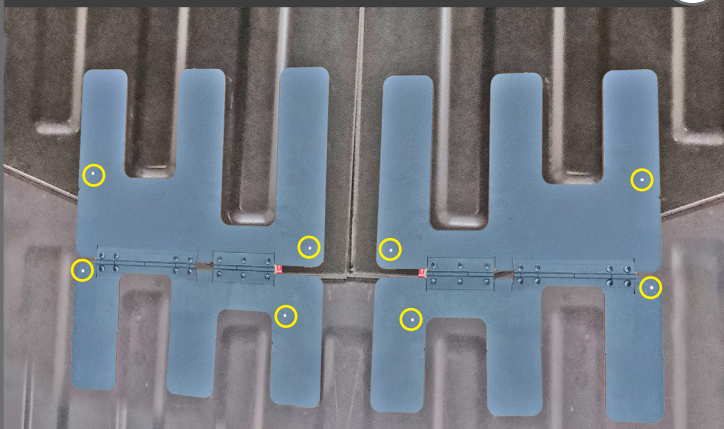

Install the hinge to hardtop with bolts ,plastic washers,metal washers and lock nuts. Install the plastic washer on top of hinge (This is avoid water penetration in the vehicle from bolt hole edge) check Figure 14. May require (2) person assembly.

Extra Security Bolt version

16

