



CVE MONITOR®

Progressive's new CVE Monitor v3 tracks tool activity, allowing users to view data on the display or from comprehensive reports using OnDemand or the new CVE Live System. Features include:

- 7-digit LCD display with a push button to move through the display modes.
- 16GB flash drive for file storage.
- Replaceable battery.
- Water resistant with an ingress protection rating of IP58.
- Maximum temperature: 190° F (90° C). For heat protection, refer to the Insulators available on pages F-10 and F-11.
- Recommended mounting is on the stationary half of the mold.
- Dimensional compatibility with Progressive's mechanical CounterViews.
- Mini USB connectivity for data retrieval with cables sold separately.



MOUNTING OPTIONS

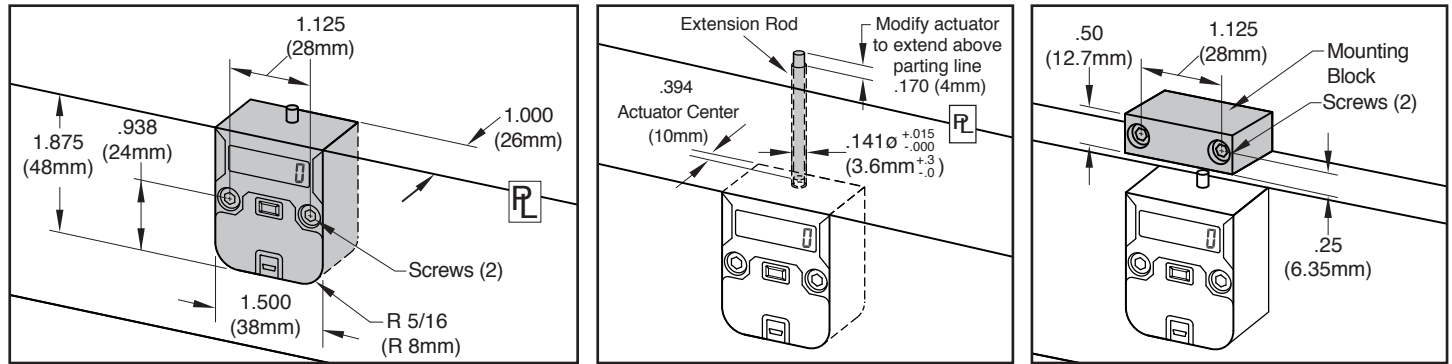

CATALOG NUMBER	DESCRIPTION
CVE-O	CVe Monitor including #8-32 x 1" SHCS (2) and M4 x 25mm SHCS (2)

CATALOG NUMBER	DESCRIPTION
CVE-INT	Internal Extension Rod (8" / 200mm)
CVE-EXT	External Mounting Block including #8-32 x 1" SHCS (2) and M4 x 25mm SHCS (2)

How to Order:

- For installation below parting line (ie. rails as shown in the center graphic above), order (1) CVE-O and (1) CVE-INT.
- For installation outside of the mold (right graphic), order (1) CVE-O and (1) CVE-EXT.

ON-MOLD DISPLAY MODES

Each device is provided at -25 cycles to allow for mold set up and initialization of the CVE Monitor. Once it reaches zero (0), all timers and data will reset on the monitor. During production, users can press the button on the front of the monitor and review the following information on the display:

Cycle Count

Total cycles for the life of the mold is presented on the main screen.



Efficiency Percentage

The percentage of time that the mold has been actively cycling vs being idle.



Cycle Time

Since the first production cycle, cycle time for the life of the mold.



Efficiency Percentage-Recent

The percentage of time the mold has been active in the past 500 cycles.



Cycle Time-Recent

Cycle time for the past 500 cycles is shown in seconds.



Cycle Count Reset

Press and hold button to reset separate counter to 0 for interim monitoring of cycles.



Mold Temperature

View current temperature experienced by the monitor (°C) by pressing button twice.



Flash Drive

Utilize the 16GB flash drive by connecting the CVE to a PC/Tablet with an industry-standard mini USB cable, sold on page F-2.



CVe MONITOR®

ON DEMAND ALERT MODES

Once data is initialized using the complimentary OnDemand software (from www.CVeMonitor.com) users can choose to be alerted to the following sets of conditions for the CVe Monitor.

Preventive Maintenance

During initialization, Preventive Maintenance (PM) checkpoints are entered and saved onto the CVe Monitor. If a PM checkpoint is exceeded, the CVe Monitor enters the PM alert mode and displays both a wrench icon and PM Due as shown at right.



When a PM is performed and entered via OnDemand or by the in-mold actuation/button push combination, the next checkpoint for the PM will be written. If no PM is performed, the CVe Monitor will remain in PM alert mode until the user performs all PMs whose thresholds have been exceeded.

Cycle Time

During initialization, the target cycle time can be written to the monitor using OnDemand. Any variation greater than 2% from the target will enter the alert mode and display the clock icon as shown at right. When the cycle time returns to within 2% of the target, the alert is removed.



Efficiency

During initialization, the target efficiency can be written to the monitor using OnDemand. Any variation greater than 2% from the target will enter the alert mode and display the percentage (%) icon as shown at right. When the efficiency returns to within 2% of the target, the alert is removed.



Low Battery

The CVe Monitor has a battery life of approximately 4 years in typical molding environments where temperatures are controlled. When the battery reaches a specified level, the display will show a battery icon as shown at right, and the replacement kit can be ordered separately below. This is the indication to replace the battery, which can be ordered by contacting Customer Service.



RETROFITTING

Users can view additional data by double-clicking the button on the monitor:

Retrofit CVe for CounterView Tools

During initialization, molders can start the cycle count with the tool's actual cycle count from an existing CounterView or known cycles from maintenance records. Once entered, the user can see the total cycles for the tool, which includes the count of the cycles from the counter and those run with the CVe Monitor.



In the graphic at right, the tool had 1,000,000 cycles on it originally, but ran 507,288 after the CVe Monitor was installed.



CABLES AND CONNECTIVITY

Using a USB cable, users can connect the CVe Monitor to their computer or tablet and view data in OnDemand, outlining the reason for the report generation. Notes can be included and user information is recorded for historical reference. More details about OnDemand are on the following pages.



OnDemand Activity Log [Software Version 3.1.0/2.6.1/3.1.9]									
CVe Initialize Date	November 23, 2017	December 17, 2017							
Device ID	MIX1234	MIX1234							
Tool ID	85658	85658							
Blower Housing									
Part ID	ABT57	ABT57							
Program Name	Mocha	Mocha							
Customer	Crimson Fan	Crimson Fan							
Target Efficiency %	N/A	94%							
Target Cycle Time	N/A	7.5							
Initial PM Point	50000	50000							
Target PM Interval	100000	100000							
Cycles Prior to CVe Installation*	1000000	1000000							
QIS# ID	N/A	ABT1							
ASSET ID	N/A	0356-5686							
Reason for connecting CVe Monitor									
Date/Time	Battery	Cycles	OD User	Conn. By	Company	Destination	REV	PM	Notes
October 4, 2018	OK	507,288	INJECT1	Blake Fitz	Injection Tech	Crimson@crimson.com	N	Y	N/A Replaced damaged core pin in cavity 4
October 4, 2018	OK	506,534	INJECT1	Blake Fitz	Injection Tech	Crimson@crimson.com	N	Y	N/A Date Pull
September 19, 2018	OK	491,274	INJECT1	Blake Fitz	Injection Tech	Crimson@crimson.com	N	Y	Pulled from production for mold operational issues. It is being sent for evaluation and rework
September 15, 2018	OK	482,567	MOLDHOU1	Chuck Louse	Mold House	Crimson@crimson.com	N	Y	N/A Full PM Cavity #2 was shutdown
June 28, 2018	OK	364,001	MOLDHOU1	Chuck Louse	Mold House	Crimson@crimson.com	N	Y	N/A Full PM
May 31, 2018	OK	314,856	MOLDHOU1	Chuck Louse	Mold House	Crimson@crimson.com	N	Y	N/A Full PM
April 28, 2018	OK	260,002	MOLDHOU1	Chuck Louse	Mold House	Crimson@crimson.com	N	Y	N/A Full PM Cavity #2 was shutdown
April 4, 2018	OK	211,563	MOLDHOU1	Chuck Louse	Mold House	Crimson@crimson.com	N	Y	N/A Full PM
March 22, 2018	OK	193,268	INJECT1	Blake Fitz	Injection Tech	Crimson@crimson.com	N	Y	N/A 3 cavities are shutdown. Pulled for evaluation and repair
February 7, 2018	OK	106,235	MOLDHOU1	Chuck Louse	Mold House	Crimson@crimson.com	N	Y	N/A Full PM
January 10, 2018	OK	58,725	MOLDHOU1	Chuck Louse	Mold House	Crimson@crimson.com	N	Y	N/A Full PM
December 17, 2017	OK	9,265	MOLDHOU1	Chuck Louse	Mold House	Crimson@crimson.com	N	Y	N/A Initial mold inspection. There is no wear or damage to mold following initial run. Targets are set. Mold is released for production
November 23, 2017	OK	0	MOLDHOU1	Chuck Louse	Mold House	Crimson@crimson.com	N	Y	N/A Mold is completed and released for sampling

CATALOG NUMBER	DESCRIPTION
CVEL-DATA9	USB 2.0 to Type B Mini 9 Foot Long, Right-Angle Cable
CVe-REPLKIT	Battery Replacement Kit for the CVe Monitor.



CVe ONDEMAND®

Drive comprehensive reporting using data from the CVe Monitor when running OnDemand software, available at no charge from CVeMonitor.com. OnDemand software enables the user to generate Adobe Acrobat (.pdf), Excel (.xls), and encrypted (.enc) reports to share with customers and other colleagues with these metrics:

- A: When the CVe is initialized, users can identify their tool and align with the device serial number which is tracked on reports utilizing different field options.
- B: The target cycle times and efficiency percentages can be entered. OnDemand also supports ten languages: English, German, Mandarin, Spanish, French, Italian, Japanese, Korean, Portuguese and Thai. Reports, generated in the chosen language, compare actual values to targets, providing a quick view of any variances.
- C: Statistics are provided to show quantity of total cycles and inactivity for the life of the tool.
- D: Weekly sessions are presented graphically to show production efficiency levels.
- E: Weekly cycle time and maximum mold temperature tracking identifies tools with variances over the past year.
- F: The productivity portion of the report takes the target preventive maintenance (PM) points set by the molder and compares them to actual maintenance pulls.
- G: The Maintenance Tab has nine user-definable PM points. In addition, customers can perform maintenance without having their laptop or computer near the CVe Monitor. By holding down the button, cycling the monitor once, and releasing the button, an event will be recorded. This is then added to the OnDemand reports when run.

CVe ON DEMAND
CVe Device ID: MKX1234

Status: Please click "Generate Report" to continue

Tool Info | Target Data | Settings | Support | Reports

A Customer: Crimson Fan, OEM ID: ABT1, Program Name: Mango, Part ID: Blower Housing ABT5, Asset ID: 235-5689-LN, Tool ID: 8565B

Get CVe Data | Generate Report

CVe ON DEMAND
CVe Device ID: MKX1234

Status: Data ready... Click "Generate Report" button to save

Tool Info | Target Data | Settings | Support | Reports

B Target Efficiency (%): 94, Target Cycle Time: 7.5, Initial PM Point: 10000, Target PM Interval: 50000

Get CVe Data | Generate Report

CVe ON DEMAND - (Email Enabled)
CVe Device ID: OKN0343

Status: Listening for response from Monitor

Tool Info | Target Data | Maintenance | Settings | Support | Reports

Maintenance Targets in Effect | Current Cycle Count: 3,950,041

Title	Interval	Last Performed	Next Due
In-Press Maintenance	50,000	3,898,055	3,948,055
B-Side Teardown	200,000	4,047,082	4,247,082
A-Side Teardown	400,000	4,047,082	4,447,082
Cooling System Maintenance	500,000	4,003,950	4,503,950
Tool Refurbishment	10,000,000	NA	10,000,000
Initial New Tool Maintenance	5,000	4,873	NA

Get CVe Data | Add PM Requirement

AST TECHNOLOGY ©Copyright 2015 AST Technology All rights reserved

Device ID: MKX1234 | Program: Green | OEM ID: ABT1 | Asset ID: 354-1856 | Part ID: Blower Housing ABT57 | 04 Oct 2018

Tool ID: 8565B

94% Target Efficiency (%) | 7.5 Target Cycle Time | 100% Since Last Report Efficiency % | 7.2 Since Last Report Cycle Time | 94% Last Full Week Efficiency % | 7.4 Last Full Week Cycle Time | 92% Life-To-Date Efficiency % | 8.5 Life-To-Date Cycle Time

Legend: Within Target 2%, Between 2%-9%, Outside Target 9%

Life-To-Date Cycles: 507,288 | Cycles since last: 24,721
Cycles Prior to CVe Installation: 1,000,000
Hours Idle: 111 | Repair: 0
Hours in Sleep Mode: 6,287 | Part Revision: Never
Hours in Active Mode: 1,197 | General Query: 764 | Report: 764

D Efficiency: Active Time, Idle Time, Sleep Time (Hours)

E Cycle Time: Cycle Time Active, Total Cycles (Seconds)

F Productivity: Initial PM Point: 10,000, Cycles-Target: 9,265, Cycles-Actual: 9,265, Target PM Interval: 50,000, Cycles until PM: 25,279

Device ID: MQM4767 | Program Name: Mocha | OEM ID: ABT1 | Asset ID: 354-1856 | Part ID: Blower Housing ABT59 | 13-Sep-19

Tool ID: 8565B | Current Cycle Count: 63,467 | Cycles until In-Press Maintenance: 1,000 | Last In-Press Maintenance: 63,467 | Date of last In-Press Maintenance: 9/13/2019 9:44

Previous 100 In-Press Maintenance Events

G Trailing 5 Weeks: On-Time PM 68 (90.7%), Overdue PM (<10%) 2 (2.7%), Overdue PM (>10%) 10 (12.7%)

Life To Date: On-Time PM 1420 (96.1%), Overdue PM (<10%) 40 (2.7%), Overdue PM (>10%) 110 (7.2%)