

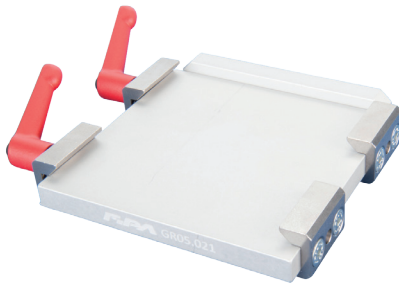

Quick-change systems – square, robot side, without fittings

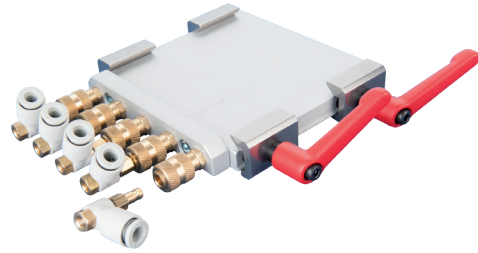

GR05.041



GR05.041 incl. quick-connection couplers

Product notes

- > Manual interface between robot and gripper system
- > Minimized down time due to fast gripper change
- > Available in four sizes
- > Clamping levers included in scope of delivery
- > Base plates and pneumatic connections not included in scope of delivery

Technical data

Item no.	Industry standard code	Number of pneumatic connections	Compatible hose \varnothing [mm]	Lifting force [N]	Weight [g]	Accessories
GR05.041	GR-0	5	6	50	315	Gripper mounting plate: GR05.042 Quick-connection coupler: KIT1-GR05.041
GR05.021	GR-1	5	6	100	570	Gripper mounting plate: GR05.022 Quick-connection coupler: KIT1-GR05.021
GR05.031	GR-2	5	6 / 8	200	1,970	Gripper mounting plate: GR05.032 Gripper mounting plate: GR-XL05.032 Quick-connection coupler: KIT1-GR05.031
GR05.051	GR-3	5	6 / 8	400	4,520	Gripper mounting plate: GR05.052 Gripper mounting plate: GR-XL05.052 Quick-connection coupler: KIT1-GR05.031

Dimensions

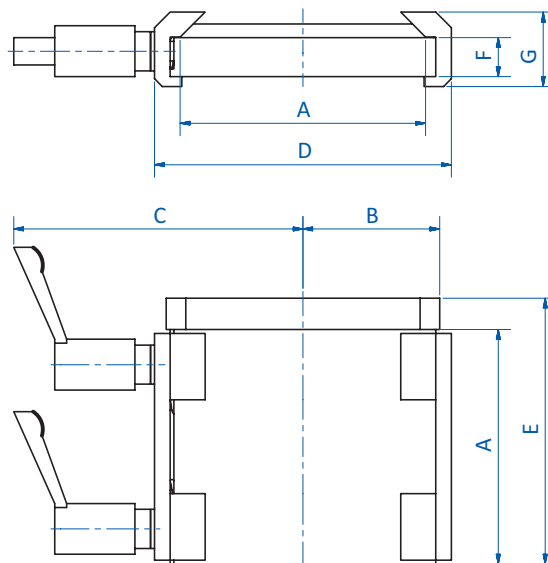

GR05.041 | GR05.021



Quick-change systems | S Series

Quick-change systems – square, robot side, without fittings

Dimensions

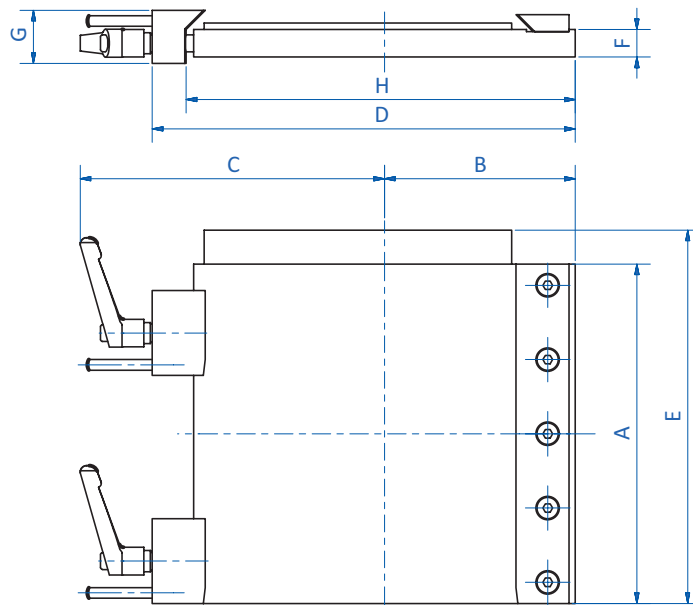

GR05.031

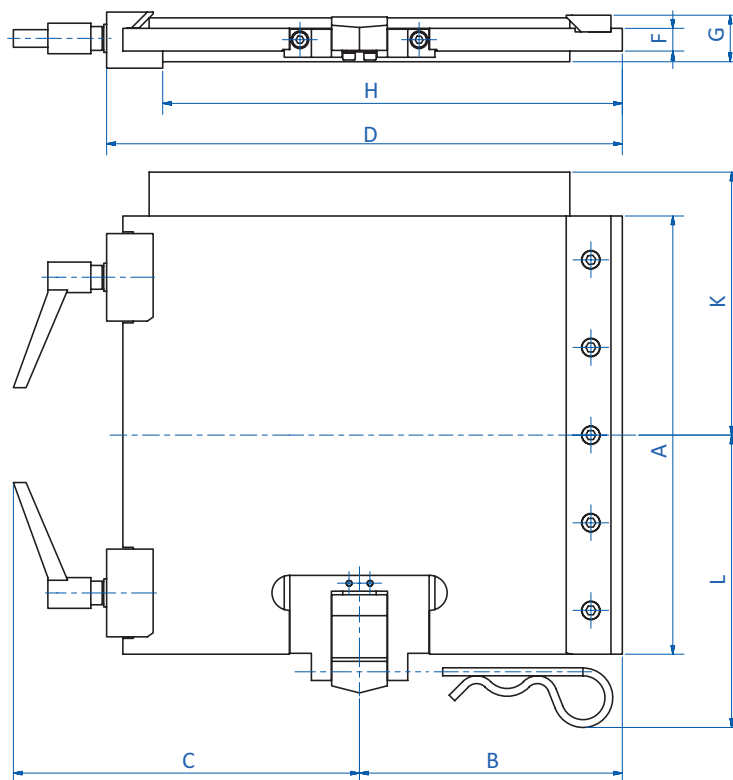

GR05.051

Item no.	A [mm]	B [mm]	C [mm]	D [mm]	E [mm]	F [mm]	G [mm]	H [mm]	K [mm]	L [mm]
GR05.041	60	38	74	76	68	10	19	62	--	--
GR05.021	100	57.5	91.5	115	110	10	20	101	--	--
GR05.031	160	90	143.5	198	176	13	25	183	--	--
GR05.051	250	150	197.5	290	--	13	32	259	150	167