



Pneumatic centering units



STRONG HOLDING FORCE

Product notes

- > Single-acting centering element for high-precision demolding
- > Strong holding force in the coupled system
- > Guiding sleeve embedded in the mold
- > Optional position monitoring (locked/unlocked) via PNP/NPN sensors
- > Sensor is fixed to centering unit via mounting bracket GR07.520S clamping diameter 20 mm
- > PNP and NPN sensors: C-Nut, straight: GR04.198, GR04.198/NPN

Technical data

Item no.	Description	Holding force at 6 bar (87 psi) [N]	Accessories
GR07.520	Centering unit	750	Sensor: GR04.198 Sensor: GR04.198/NPN Sensor mounting bracket: GR07.520S
GR07.521	Guiding sleeve	--	--

Dimensions

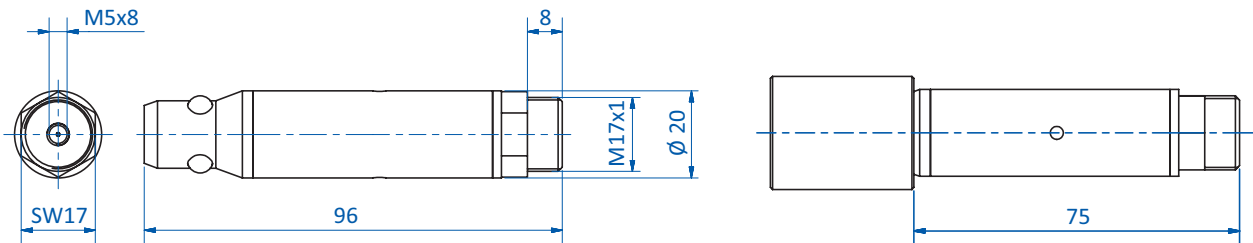

GR07.520

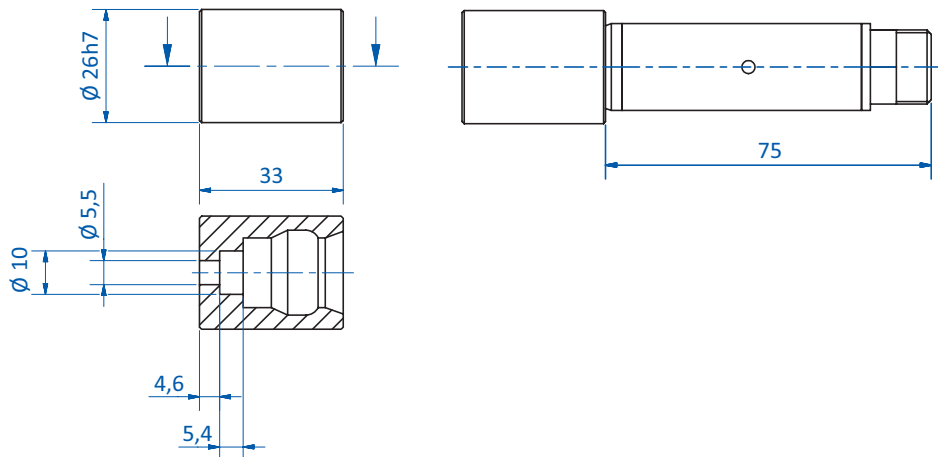

GR07.521