

Blown Film Die

Dies and Tooling Worksheet

How To Order

To process an order or quote please specify the following information

- "C" = Full Circumference of Die Including Heater Bands and J-Boxes
- "L" = Height of Outer or Upper Lip
- "B" = Height of Die Body and Mandrel

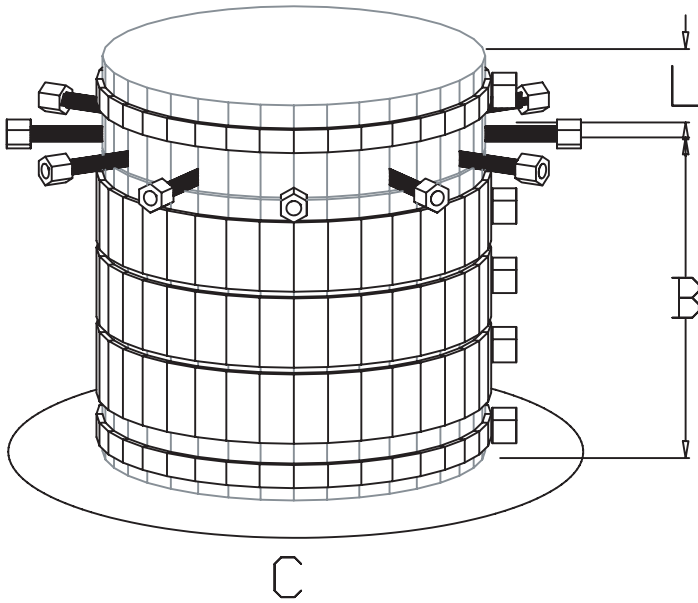

LINE # _____

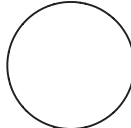
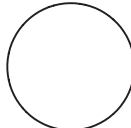
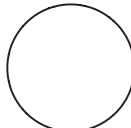
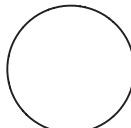
C		L	_____	B	_____
C		L	_____	B	_____
C		L	_____	B	_____
C		L	_____	B	_____

Customer Information

Contact Name _____
 Company _____
 Address _____
 City, State, Zip _____
 Telephone _____ - _____ - _____
 Fax _____ - _____ - _____

Rep/Distributor _____
 Salesperson _____
 Telephone _____ - _____ - _____
 Fax _____ - _____ - _____
 Machine Brand _____
 Tons/Ounces _____
 Temperature Range _____

Do you have questions? Please call us toll free 1 (305) 887-6920 _ or E-mail us at info@solucionesplasticas.com also visit our website at <http://www.solucionesplasticas.com>