

BUCKET GRAPPLE

A Product of Paumco Products, Inc.
500 Congress St W Maple Lake, MN 55358

Please read entire instructions before assembly and use.

⊕WARNING⊕

The Paumco Bucket Grapple is intended to be used with various operating equipment such as a utility tractor or a skid loader. Operator must understand and operate his/her machinery in a safe manner BEFORE using the Paumco Bucket Grapple.

ASSEMBLY INSTRUCTIONS

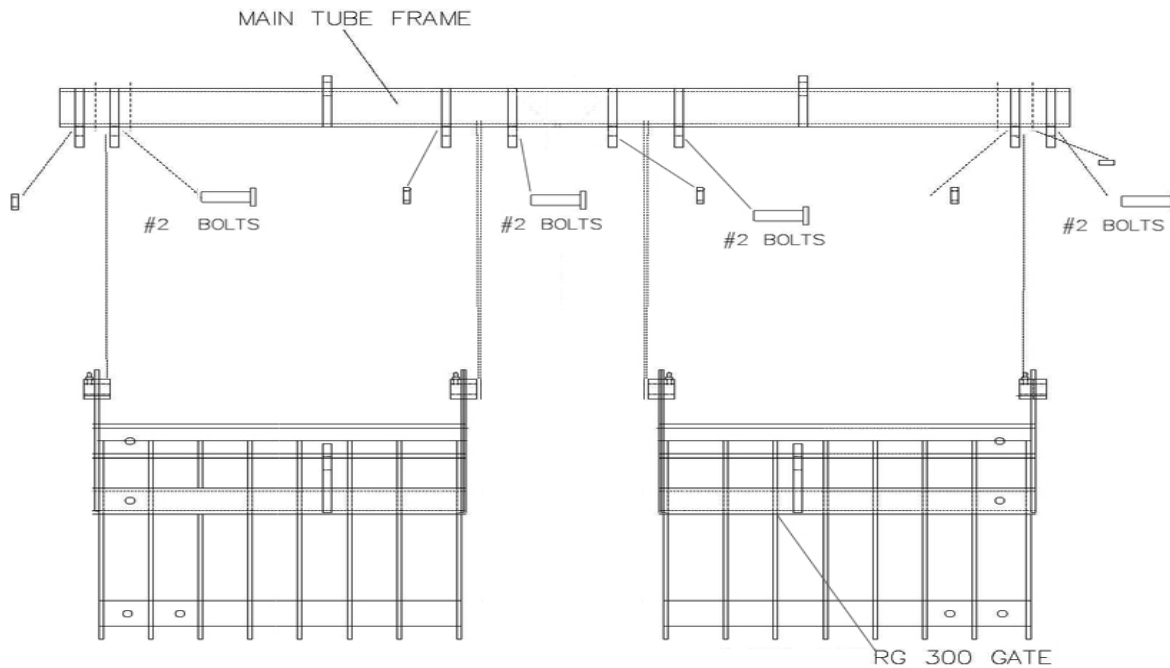

- 1) Prior to assembly, lay out all parts as shown in assembly picture and hardware list attached and inspect to insure all parts were received.
- 2) Using #2 Bolt on all four of the included gate hinges, fasten gates into the two center hinge brackets. Then using the same bolts, fasten both sides into each end hinge bracket. (Do not over tighten!) Make sure gate opens and closes freely.
- 3) Insert Telescope Frame into Main Tube Frame as shown and adjust Telescope Frames to width of outside of bucket. Use the #3 Bolts to secure Telescope Frame to Main Frame. Tighten securely.
- 4) Assemble cylinders to unit as shown in upper right view using the 4 pins to secure.

5) Place unit onto bucket for mounting with cylinders FULLY EXTENDED. (Fittings may need to be removed to fully extend) Front of Tines should be placed 1 3/8" inside front edge of bucket. Using spacers (not provided), create a maximum 1/4" gap under tines and a minimum 3/4" gap under the Main Tube Frame for space needed depending on bucket height. (These measurements insure unit opens and closes to full and proper positions.)

6) While cylinders FULLY EXTENDED and spacers in place, mark the four mounting holes on bucket sides. With punch, center mark holes to be drilled. Then first use a 1/4" drill bit to drill through bucket side followed by a 37/64" (.578) drill bit opening the holes to proper diameter.

7) Using #6 Bolts, bolt unit to bucket sides

8) Unit is now ready to connect to your hydraulic system. See your owner's manual for proper hose, connections and procedures for connection and operation.

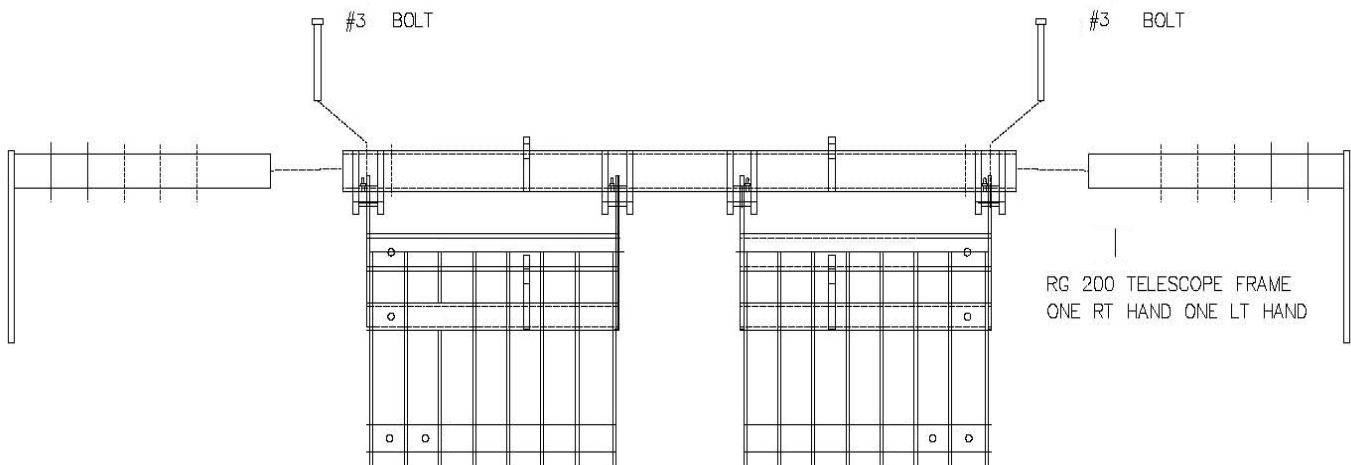
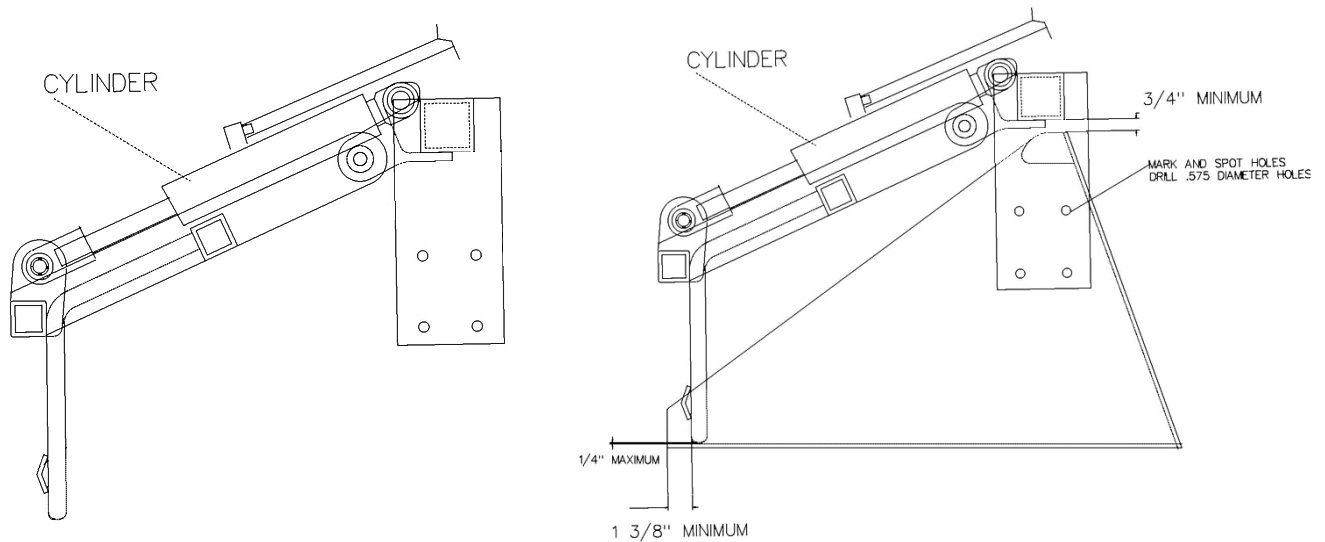

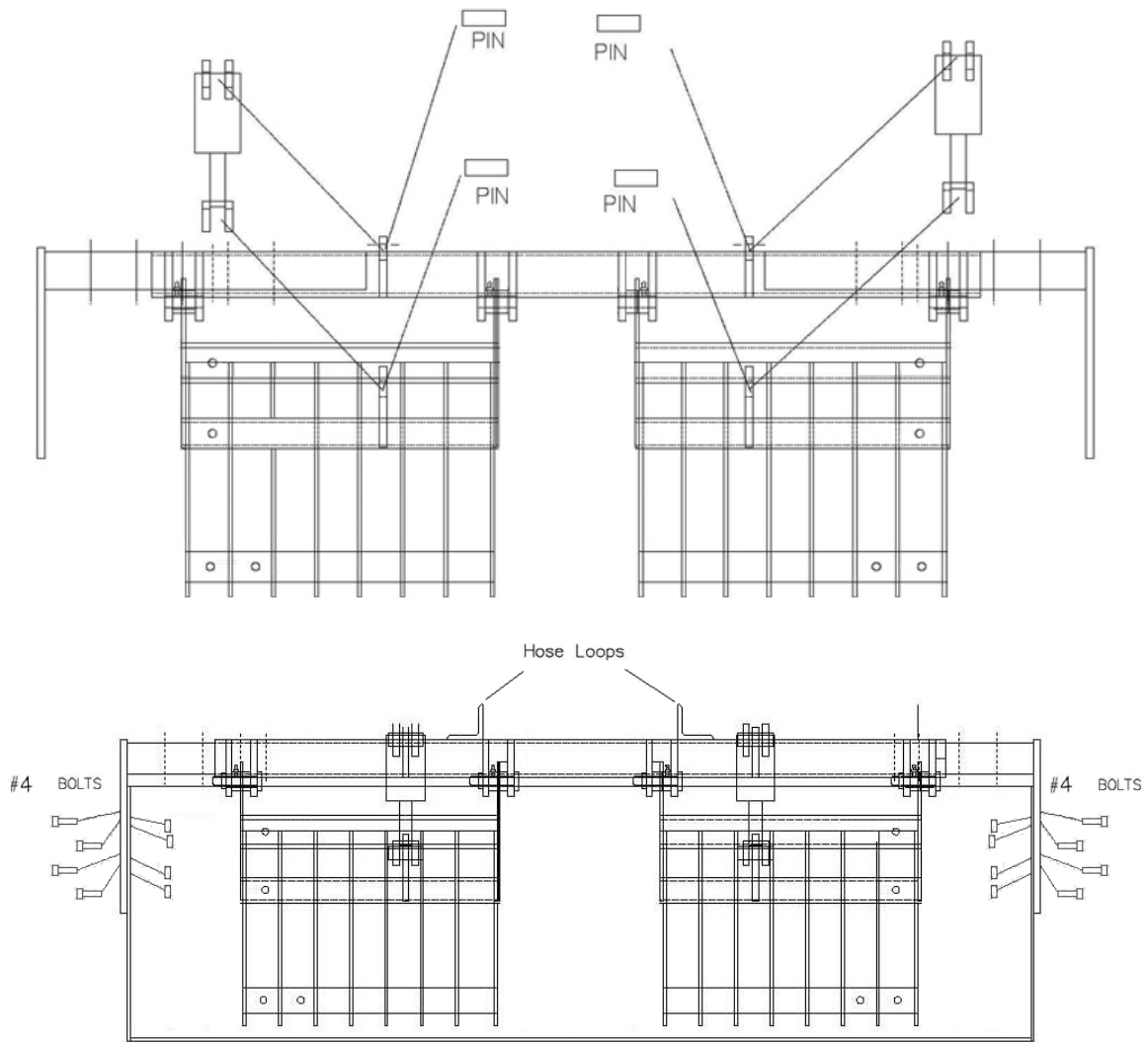

Hardware List

Name	Size	QTY
#2	3/4"-10 x 4" Long Bolt	4
#3	1/2"-13 x 4" Long Bolt	2
#4	9/16"-12 x 2 Grade 8 Bolt	8
#5	3/4"-10 Lock Nut	4
#6	3/4" Washer	8
#7	1/2"-13 Lock Nut	2
#8	1/2" Washer	4
#9	9/16"-12 Lock Nut	8
#10	9/16" Washer	16
#11	Cylinder Hinge Pin w/ Key	4

Hydraulic Hose & Fittings List

Item	Description	QTY
1	¾-16 90° Swivel. Straight thread ORB **MUST BE USED**	4
2	3/8" Male Pipe Swivel 3/8" Hose NPTF	6
3	3/8 Female Pipe Swivel NPSM Tee	2
4	19" Long 3/8 4000 psi Hydraulic Hose	2
5	20" Long 3/8 4000 psi Hydraulic Hose	2
6	Approx. 8ft 3/8 4000 psi Hydraulic Hose	2
7	3/8" Male Pipe 3/8" Hose NPTF 30° Cone Seat	2
8	Hydraulic Fluid Restrictor. If grapple operational speed is slow. Increase orifice size by 1/64" at a time to a safe and reasonable operational speed. (REMOVE ORIFICE FROM LINES TO INCREASE ORIFICE DIAMETER.)	1

⊖Item #1 is **REQUIRED** for assembly. Items #2 - #8 are recommended.⊖

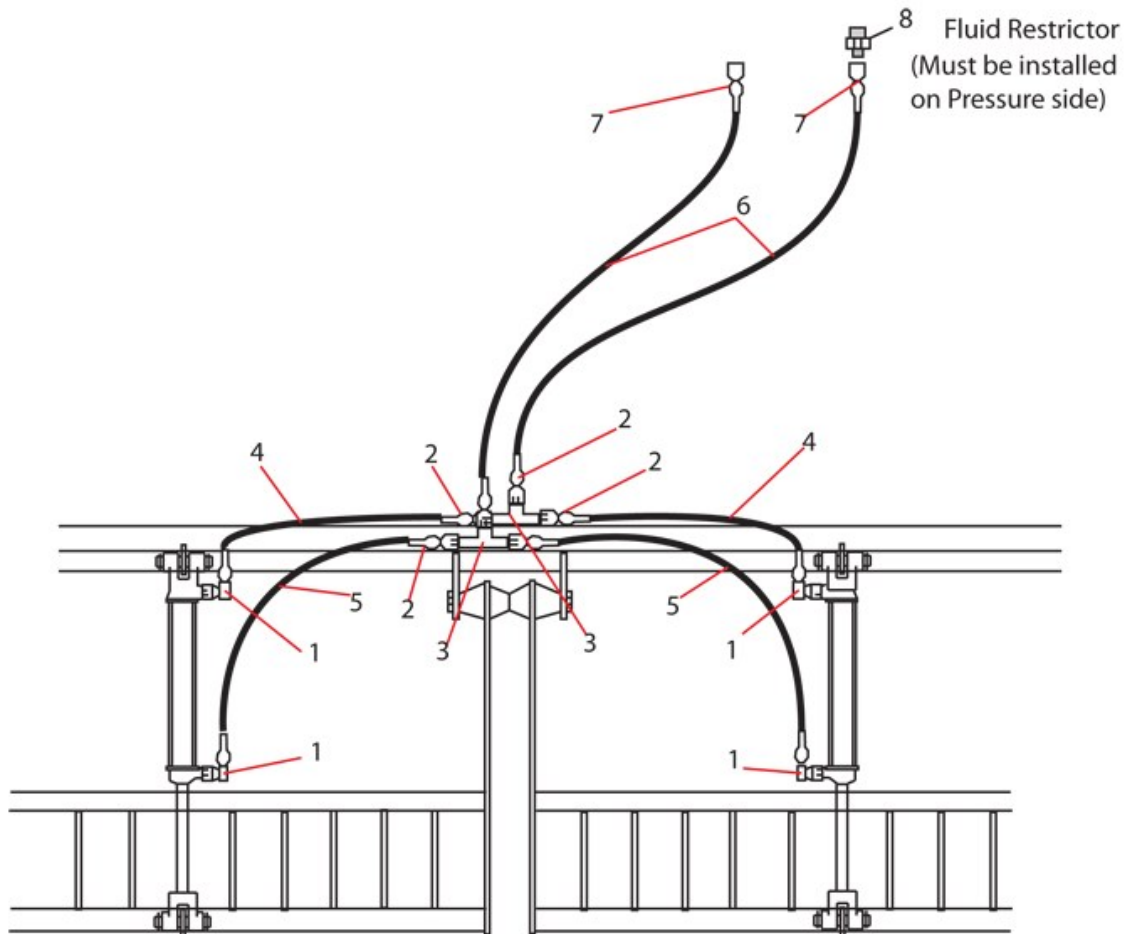

Warranty Information

Paumco Bucket Grapple is manufactured by Paumco Products, Inc.

Paumco Products, Inc. warrants to the original consumer- purchaser that this product shall be free from defects in workmanship and materials under normal and reasonable use and correct assembly for a period of one (1) year from date of original purchase.

Paumco Products, Inc. will, at its option, refinish or replace any product or part found to be defective during the warranty period. Paumco Products, Inc. may require you to return the part(s) claimed to be defective, for its inspection, freight or postage prepaid.

Paumco Products, Inc. requires proof of purchase on all warranty claims.

This warranty does not include the cost of any inconvenience or property damage due to failure of the product and does not cover damage due to misuse, abuse, accident, damage arising out of transportation of the product, or damage incurred through commercial use of the product. This express warranty is the sole warranty given by Paumco Products, Inc. Paumco Products, Inc.'s maximum liability, in any event, shall not exceed the purchase price of the product paid by the original consumer-purchaser.

Customer Service Center

***If you need assistant or replacement parts, please call 320-526-1268,
email paumco@paumco.com or write to:***

Paumco Products, Inc.
ATTN: Bucket Grapple Department
PO Box 760, Maple Lake, MN 55358