



***Congratulations!***

**You are the new owner of TTRacing Maxx!**

**Flip to the back to get started!**

**Thank you for your support!**

# INSTRUCTION



# MAXX SERIES

## ATTENTION

1. You are advised to wear protective gloves when assembling the chair.
2. Do not tighten bolts fully until you have completed assembly.
3. It is highly recommended that you assemble the chair on a carpeted floor surface so as to prevent scratches.
4. When adjusting the chair handle, do not put your hand in between the gap of the toggle mechanism as your hand can get caught.
5. Do not use excessive force when adjusting the chair angle.
6. Do not reach for the reclining mechanism when the chair is fully tilted to avoid falling off the chair.
7. Be sure to set the rocking lever into "lock" position when you've fully reclined the chair.
8. When reclining the chair, both feet should remain firmly on the ground. Reclining the backrest with sudden or excessive force can cause the chair to tip over.
9. Sit correctly with your back fully aligned with the backrest. Do not sit on the armrests or the edge of the chair.
10. Avoid exposing the chair to direct sunlight to prevent the color from fading.
11. Gently clean the chair and avoid scrubbing the chair excessively.
12. Check the chair parts on a monthly basis to ensure they are still functioning correctly.

## WHAT'S IN THE BOX

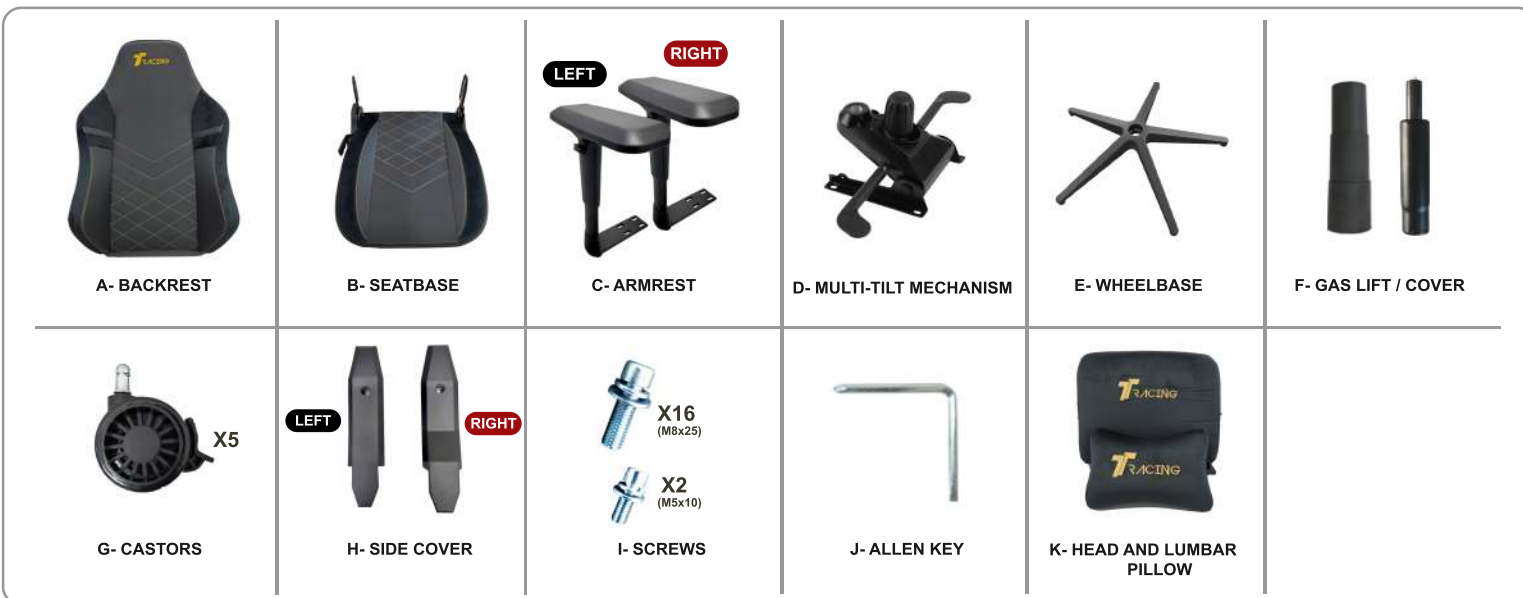

REMARKS : The screws are pre-attached to the seat to make the assembly process easier. Side cover and extra screws (if any) are packed separately inside the box.

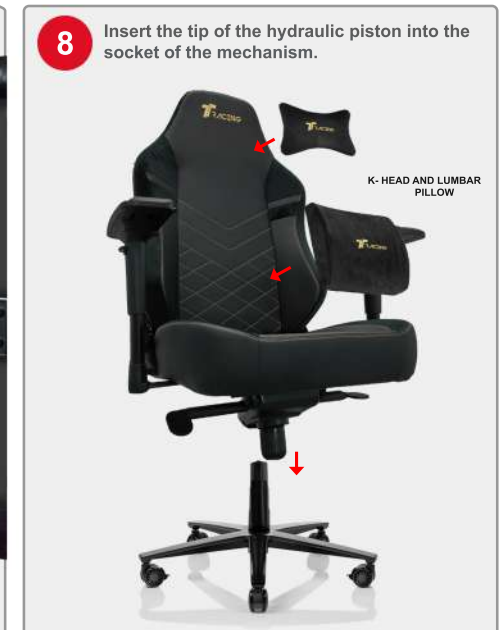
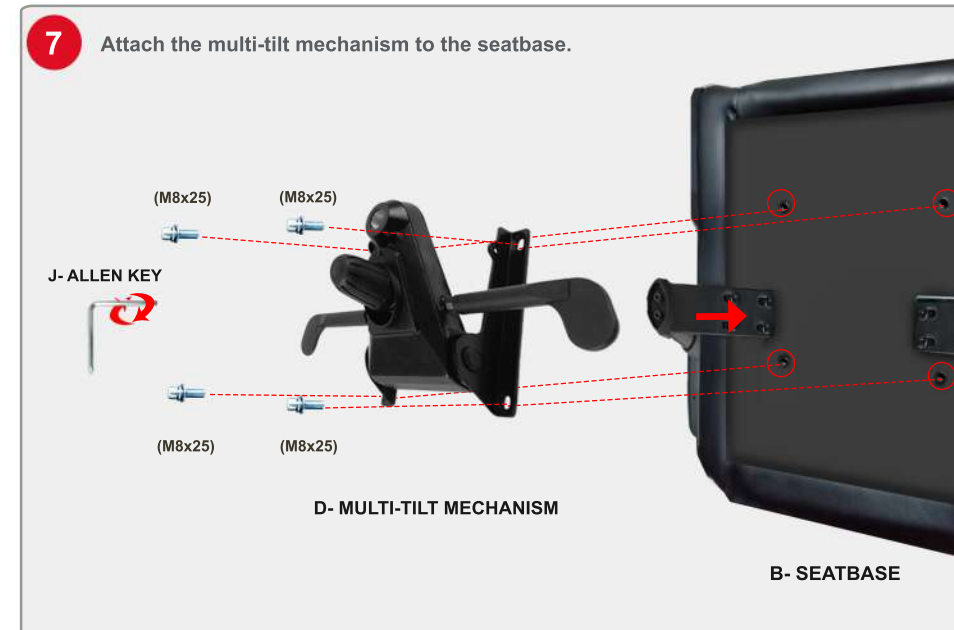
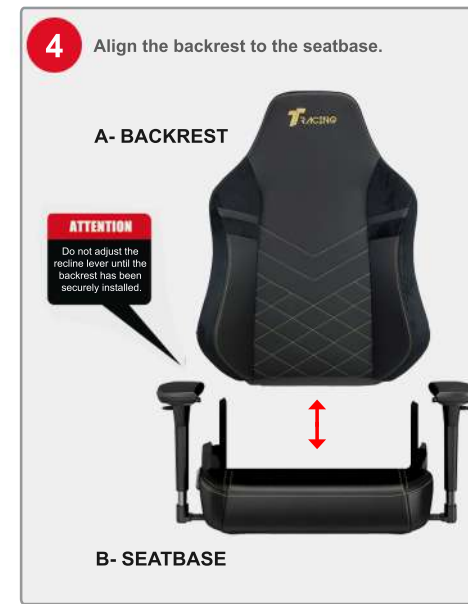
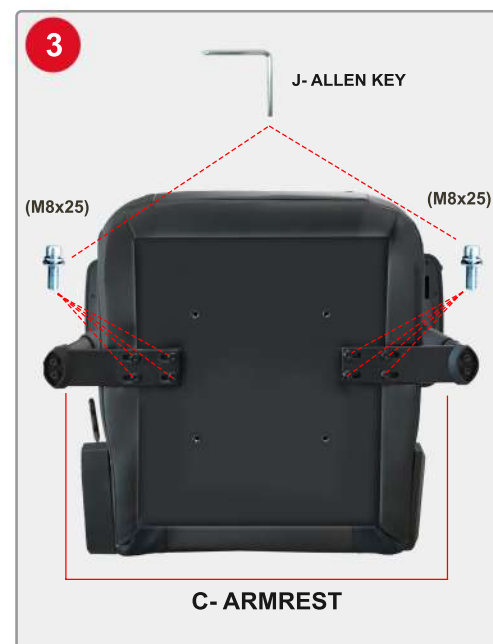

The screws are pre-attached to the seat to ease assembly process. Side cover and extra screws (if any) are packed separately and can be found in the box.



The screws are pre-attached to the seat to ease assembly process. Side cover and extra screws (if any) are packed separately and can be found in the box.