



Truck Bed Bale Spear



PART# 26-010, ASSY, TRUCK BED BALE SPEAR

Operation Manual



This safety alert symbol identifies important safety messages in this manual. Failure to follow this important safety information may result in serious injury or death.

TABLE OF CONTENTS

Intended Use	4
Personal Protective Equipment	4
General Safety Information	5
Parts List	6
Assembly Instructions	7
Installation Instructions	13
Operation Instructions	13
Maintenance	14
Trouble Shooting	15
Specifications	19
Warranty	20
Registration	21

IMPORTANT SAFETY INFORMATION



WARNING

WARNING:

Read and thoroughly understand all instructions and safety information before assembling or operating this truck bed bale spear. Failure to do so may cause serious injury or death. Do not allow anyone to operate this truck bed bale spear who has not read this manual. As with all power equipment, a truck bed bale spear can be dangerous if assembled or used improperly. Do not operate if you have doubts or questions concerning safe operation.

The installer assumes responsibility for property damage or personal injury.

Call our customer service department at 303-278-0664, or email at customerservice@agknx.com if you have any questions or concerns about the safe operation of this equipment.



DANGER

INTENDED USE

Do not use the truck bed bale spear for any purpose other than picking up and transporting hay bales. Any other use is unauthorized and may result in serious injury or death.

PERSONAL PROTECTIVE EQUIPMENT

When operating this truck bed bale spear it is essential that you wear safety gear including safety glasses, steel toe shoes and tight fitting gloves (no loose cuffs or draw strings).



CAUTION

Do Not wear loose clothing or jewelry that can be caught by moving parts of the truck bed bale spear. Keep clothing and hair from all moving parts when operating.



IMPORTANT SAFETY INFORMATION



DANGER

GENERAL SAFETY

Failure to follow warnings, cautions, assembly and operation instructions in the Operation Manual may result in serious injury or death. Read the Operation Manual before installation and operation of this truck bed bale spear.



DANGER

Do not permit children to operate this equipment at any time. Do not permit others that have not read and understood the complete Operation Manual to operate this equipment.



DANGER

Do not operate the truck bed bale spear when under the influence of alcohol, drugs or medication. Do not allow a person who is tired or otherwise impaired or not completely alert to operate the equipment.



DANGER

Never exceed the gross vehicle weight or gross axle weight rating of the vehicle. Overloading the vehicle could cause component damage resulting in injury or death.



WARNING

Always follow truck bed bale spear maintenance schedule.

PARTS LIST

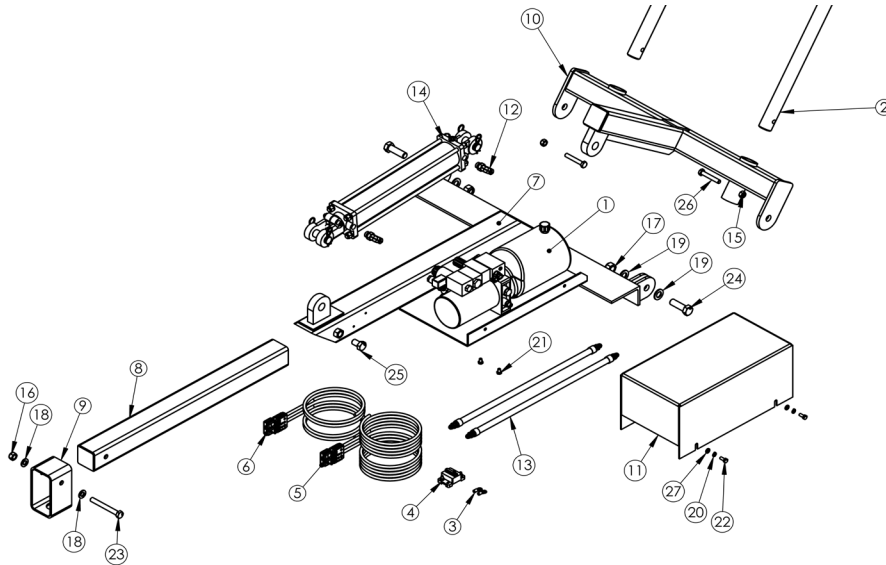

ITEM NO.	PART NUMBER	DESCRIPTION	QTY.
1	26-004	POWER UNIT, HAY SPEAR	1
2	26-005	HAY SPEAR	2
3	26-006	LUG, 5/16" STUD, #4 GAUGE WIRE	2
4	26-007	200 AMP BREAKER	1
5	26-008	POWER CONNECTOR, #4, 176"L	1
6	26-009	POWER CONNECTOR, #4, 58"L	1
7	26-011	WELDMENT, FRAME, BALE SPEAR	1
8	26-021	WELDMENT, INSERT TUBE	1
9	26-022	RECESSED HITCH COUPLER	1
10	26-023	WELDMENT, SPEAR FRAME	1
11	26-030	SHEET, PU COVER	1
12	31-023	HYDRAULIC FITTING, -8 ORB TO -6 JIC	2
13	31-024	HYDRAULIC HOSE, -6 JIC TO -6 JIC, 26.25"	2
14	31-026	3 X 16 TIE ROD CYLINDER	1
15	90576A119	NYLOCK NUT, M12	2
16	90576A120	NYLOCK NUT, M14 X 2mm	1
17	90576A125	NYLOCK NUT, M20	2
18	91166A300	WASHER, M14	2
19	91166A320	WASHER, M21	4
20	91202A238	LOCK WASHER, M8	2
21	91280A524	BOLT, M8 X 12mm	2
22	91280A530	BOLT, M8 X 1.25 X 25mm	2
23	91280A798	BOLT, M14 X 2mm X 120mm, G8.8	1
24	91280A888	BOLT, M20 X 2.5mm, PT	2
25	91280A989	BOLT, M18 X 2.5 X 30mm, G8.8	1
26	95327A698	BOLT, M12 X 75mm	2
27	98687A112	WASHER, M8	2

ASSEMBLY INSTRUCTIONS

STEP 1:

Attach the hydraulic cylinder

- Remove the pin and clip from the hydraulic cylinder.
- Place the hydraulic cylinder on the frame with the hydraulic ports facing the pump mounting frame.



STEP 2:

Hydraulic cylinder assembly

- Remove the hydraulic port plugs using a 9/16" wrench.
- Attach the o-ring fittings (P/N: 31-023) to the hydraulic cylinder. The orientation is shown below.
- Do not use teflon tape or pipe sealant on o-ring fittings.

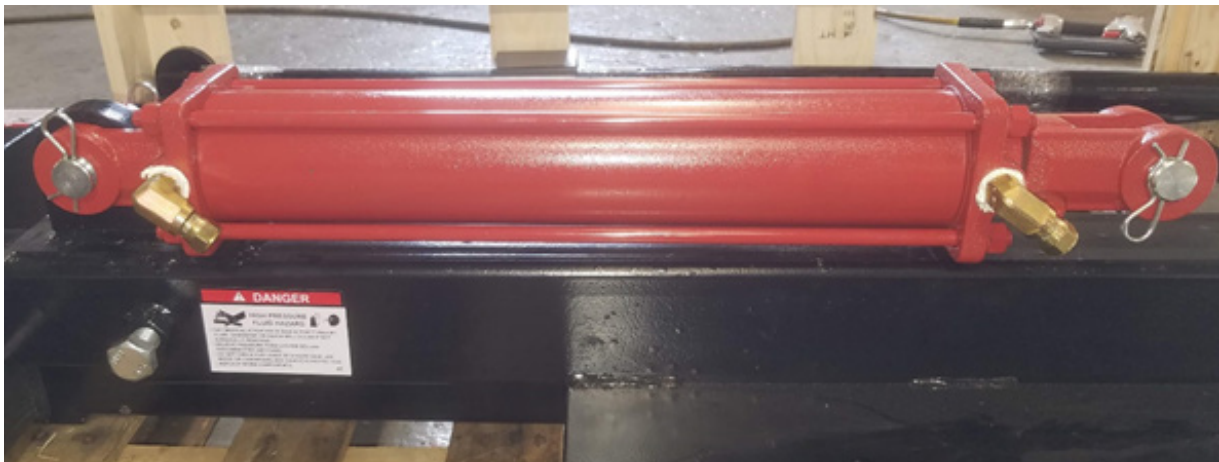

ASSEMBLY INSTRUCTIONS

STEP 3:

Hydraulic power unit assembly

- Attach the power unit (P/N: 26-004) to the frame using the M8-1.25x12mm bolts provided. Tighten the bolts using a 5/8" wrench.

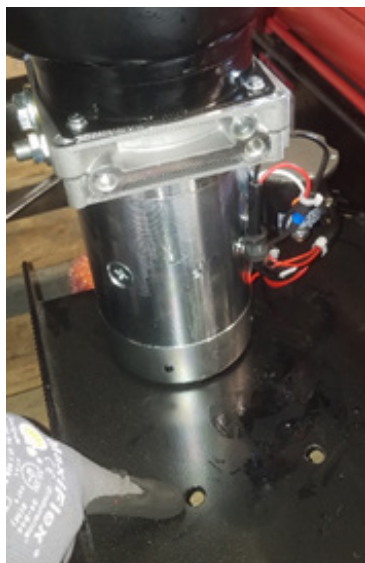

STEP 4:

Connect the power unit to the cylinder

- Remove the plastic caps from the hydraulic fittings on the valve.

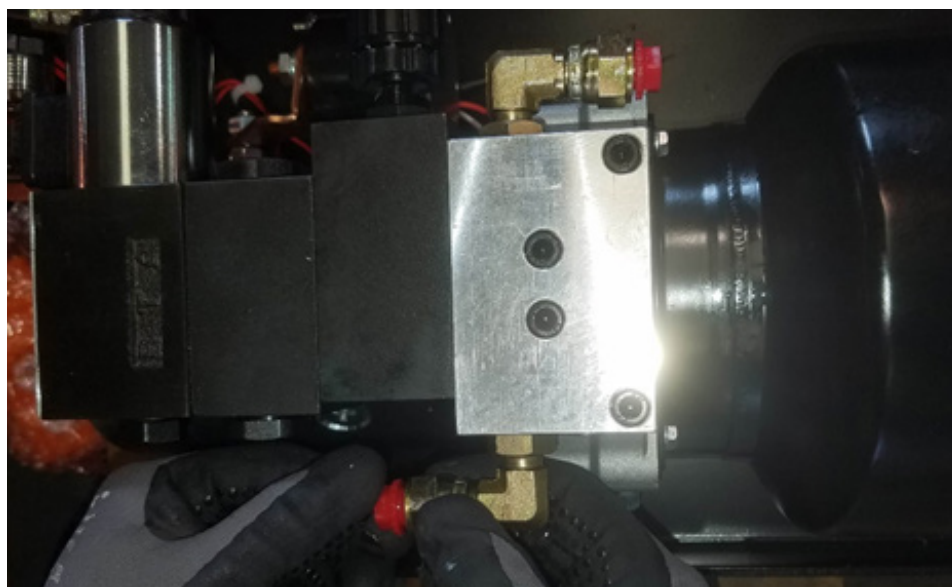

ASSEMBLY INSTRUCTIONS

- Attach the hydraulic hose (P/N: 31-024) from the hydraulic cylinder's extension port to the valve of the power unit.
- Make sure the hose doesn't spin and kink when tightening the hydraulic fittings.

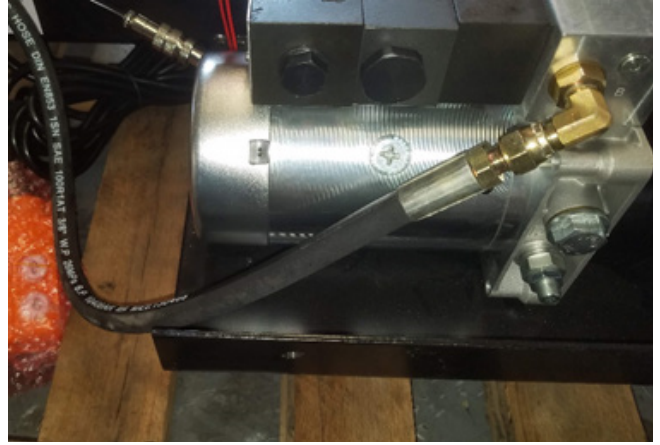
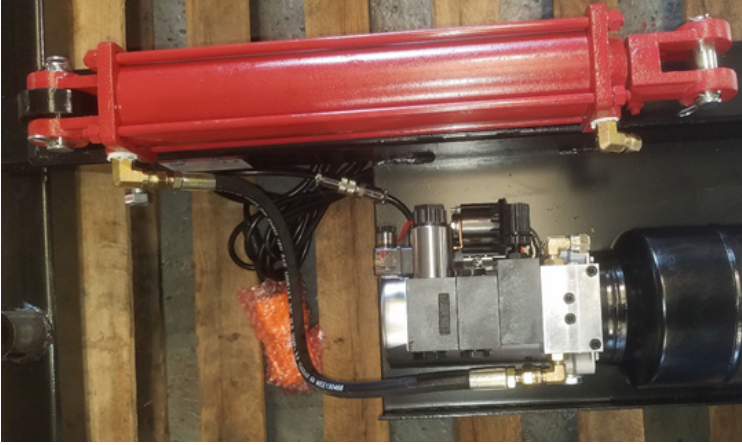

- Attach the hydraulic hose (P/N: 31-024) from the hydraulic cylinder's retraction port to the valve of the power unit.

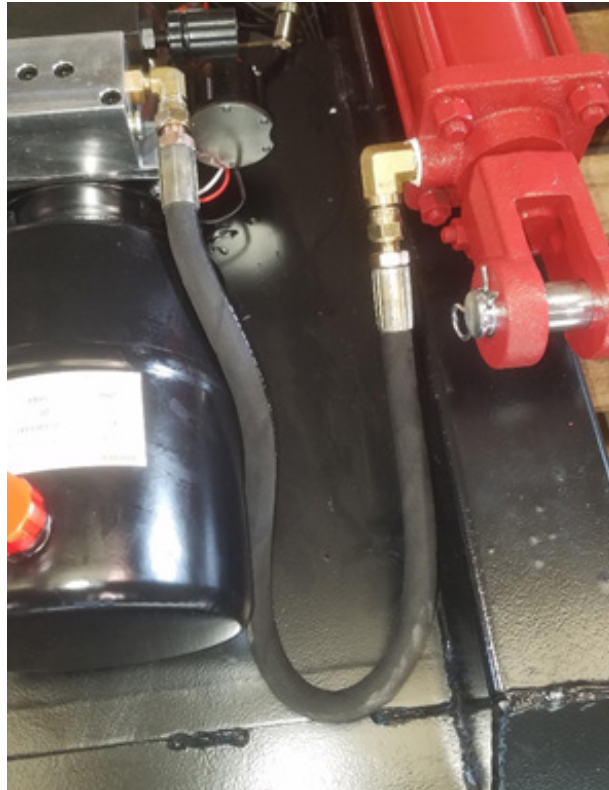

- Verify that the fitting on the valve and cylinder remain tight.

ASSEMBLY INSTRUCTIONS

STEP 5:

Wiring the power unit to the battery

- There are two different ways to mount the wires to the vehicle or auxiliary battery. A 200 Amp breaker (P/N: 26-007) is used, it is best used close to the battery. One option is to mount the breaker under the hood of the vehicle or can be attached to the frame of the bale spear. Determining where you mount the breaker will help determine the length of segments for the positive (red) wire. The wiring kit includes two sets of wires (P/N: 26-008 & 26-009), one is much longer than the other. One option would be to attach the short wires to the power unit and the long set would connect to the battery.
- The general wiring schematic is shown below

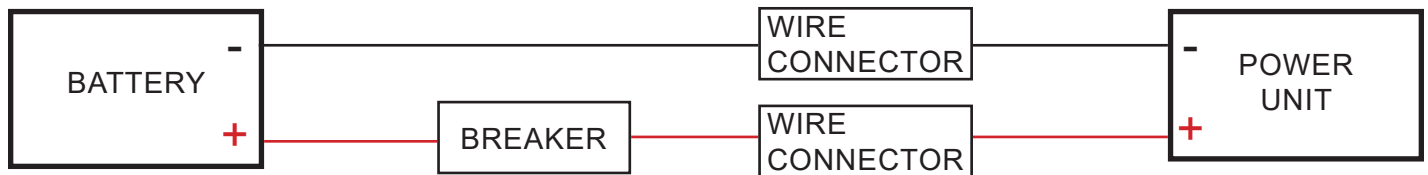

- Using a knife or wire cutters, cut the sheath of the negative (black) wire about ½". Place the wire terminal (P/N: 26-006) on the wire and crimp with wire crimpers. Verify that the wire terminal will not pull off. Remove the upper screw that attaches the starter solenoid to the pump. Replace the screw with the wire terminal sandwiched under the screw as shown in the photo below.

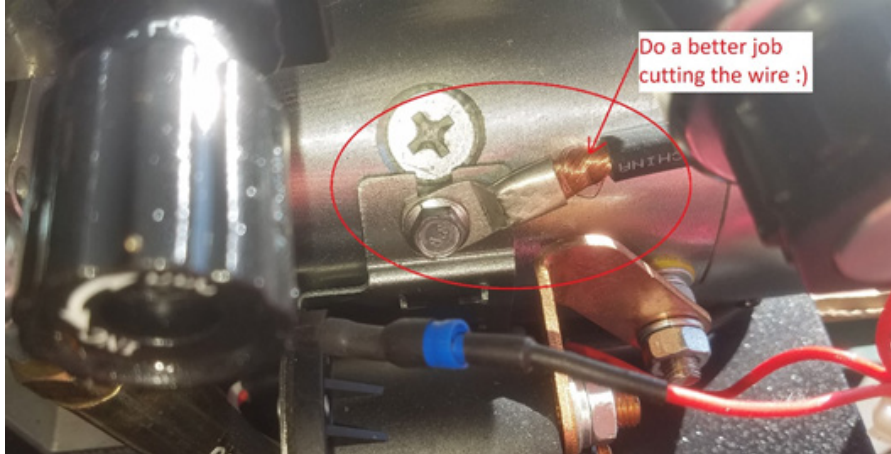

- Using a knife or wire cutters, cut the sheath of the positive (red) wire about ½". Place the wire terminal on the wire and crimp with wire crimpers. Verify that the wire terminal will not pull off. Attach the wire to the lower stud of the starter solenoid as shown below.

ASSEMBLY INSTRUCTIONS

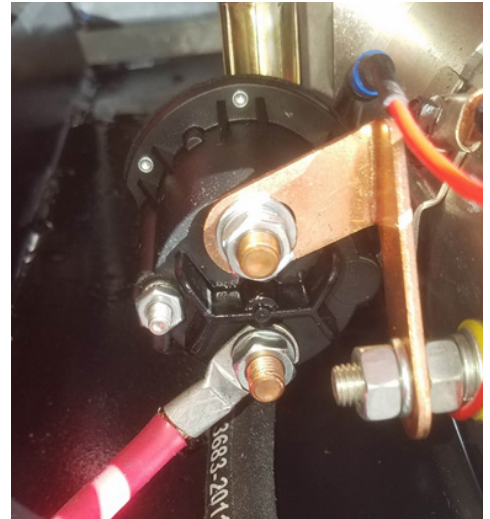

- Determine the breaker location and the length of positive wire before and after the breaker. Cut the positive (red) wire and attach a wire terminal to both ends. Attach the wire terminals to the breaker. The breaker has markings indicating which stud goes to the battery (BAT LINE) and which goes to the power unit (AUX LINE). Use a 7/16" or 11mm wrench to attach the wire lugs to the breaker.



- Cut the positive and negative wires and attach the wires to the battery of the vehicle.

ASSEMBLY INSTRUCTIONS

STEP 6:

Fill the reservoir with hydraulic fluid

Hydraulic recommendation:

ISO Viscosity Grade 22-46 cSt @ 40°C hydraulic fluid is recommended. Anti-wear, anti-foaming & rust inhibitor additives are recommended.

ATF can be used for colder climates. ATF Dexron III does not have anti-foaming agents in the fluid. Fluid aeration and cavitation can occur. Be cautious when adding fluid to the reservoir. The oil should be clean and free of impurities.

Fill the reservoir to the top line on the dipstick during initial setup. After air has been cycled out of the system fill the reservoir to the fill line.

Only fill the reservoir with the hydraulic cylinder retracted.



WARNING:

Do not mix different grades and types of hydraulic fluid.

Do not use synthetic, biodegradable or water base hydraulic fluids.



DANGER:

Never loosen a hydraulic connection under pressure. Doing so can result in a hydraulic injection and can result in catastrophic failure of the truckbed bale spear resulting in equipment damage, severe injury or death.

STEP 7:

Attach the guard

- Tuck the wires and hydraulic hoses close to the pump and place the steel guard over the pump. Attach the guard to the frame using the supplied M8 x 12mm bolts, washers and lock washers using a ½" wrench.

INSTALLATION INSTRUCTIONS

This bale spear is for use with truck beds that have a 2-5/16" ball mount for gooseneck trailers. It can be used in box truckbeds, or flatbeds with exposed or recessed balls. It can accommodate balls that are 40-54" from the rear of the bed.

- Remove the tailgate from the vehicle, refer to the vehicle's owners manual for removal.
- Place the assembly on the truckbed with the angle iron of the frame against the rear of the truck bed.
- Slide the insert tube (P/N: 26-021) out from the main frame (P/N: 26-011) and place it over the hitch ball. Slide the insert tube as far as it will go inside the main frame and tighten the locking bolt on the main frame to hold the insert tube in place.
- Attach the recessed hitch coupler (P/N: 26-022) to the insert tube prior to the previous step if your vehicle uses a recessed gooseneck ball.
- Place the spears in the spear frame (P/N: 26-023) and secure with the provided hardware.

If your vehicle does not have a gooseneck ball, use the the direct frame mounting (P/N: 26-002)

OPERATION INSTRUCTIONS



DANGER

DANGER:

Always drive with the hay spears raised unless spearing a bale.

- Approach the flat side of a single round bales with the spears as close to mid-height of the bale as possible.
- Penetrate a single bale making sure that the bale does not interfere with the vehicle truckbed, which could cause damage to the vehicle.
- Raise the bale spears and slowly drive to the destination.
- Lower the bale and drive straight forward until the spears are clear of the hay bale.



WARNING

WARNING:

The weight and position of hay bales puts a large amount of leverage on the truck. The load will affect steering and handling, drive slowly and carefully.

The vehicle suspension may bottom out due to the leverage and heavy load of hay bales. Stiffening up the rear suspension of the vehicle may be necessary.

Always lift a single hay bales with both hay spears. Damage will occur when a bale is lifted with one spear.

MAINTENANCE

Maintenance:

Hydraulic oil change is required after the initial 100 operation hours. Routine oil change should be performed every 3000 hours or 2 years after initial change.

Check hydraulic fluid level regularly before operation.

Check electrical connections regularly for corrosion on all connections and battery cables.

Load test battery often before use.

Cleaning:

Never pressure wash or hose down the power unit. The DC motor is not sealed, extended exposure to moisture will cause premature failure.

Spray light amounts of cleaner/degreaser on the power and dry with compressed air and/or rag.

Remove the red cap from the power unit tank breather cap and clean the filter element with dishwashing soap and water. Make sure the filter element is completely dry before reinstalling it back on the breather cap.

TROUBLE SHOOTING



WARNING

This information is intended for use by a service technician who is familiar with hydraulic components and understands the required safety precautions.



WARNING

Tampering or adjusting the relief valve will void warranty and could cause catastrophic failure which could result in equipment damage, severe injury or death.



WARNING

Shorting of the electrical system can occur during installation or servicing. Electrical components can cause sparks and/or fire which can lead to property damage, personal injury or death. ALWAYS disconnect the battery prior to installing, servicing or repairing of the power unit.

SYMPTOMS	Possible Cause	Correction	Notes
System inoperative	Dead or low battery	Load test battery	Charge or replace battery
	Poor ground	Ground battery directly to DC motor	Use jumper cables to jump ground only
	Dirty contacts in hand control	Clean contact in hand control with eraser	Cleaning contacts with abrasive material will cause frequent failure
	Corrosion on battery terminals	Inspect battery cables & clean battery terminals	Use of dielectric grease will prevent corrosion buildup
	Start solenoid failure	Jump start solenoid	Replace solenoid
	Rust in DC motor	Bypass start solenoid	If motor doesn't run after bypassing start solenoid, remove rear cover of motor for quick inspection.

TROUBLE SHOOTING

SYMPTOMS	Possible Cause	Correction	Notes	
Motor runs, cylinder not extending	Low battery / poor ground	Load test battery	Charge or replace battery	
	Dirty contacts in hand control	Clean contact in hand control with eraser	Cleaning contacts with abrasive material will cause frequent failure	
	Directional valve issue	Check for bent valve stem	Replace valve if stem is bent	
		Ensure coil is energizing	Double check you are getting power to coil before replacing	
		Remove valve and inspect O-rings	Replace O-rings if damaged	
		Check cross drilled holes between O-rings of valve for debris	Replace valve if spool is not shifting (for most directional valves the spool will cover half of the cross drilled holes when valve is at its rest or activated positions)	
		Ensure valve is shifting (use dipstick push on valve spool to shift valve. Look through cross drilled holes between O-rings ensuring valve is shifting)		
	Pump not priming	Remove check valve plug & activate motor momentarily to prime		
Relief valve	If relief valve is bypassing check pressure gage to ensure valve is set at proper setting as marked on power unit	Double check with equipment manufacturer ensuring the manufacturer did not adjust pressure setting at factory.		
Cylinder	Check to see if fluid is passing through the rod seals to tank	Rebuild or replace the cylinder if fluid is passing through the cylinder without moving the rod		

TROUBLE SHOOTING

Possible	Possible Cause	Correction	Notes
Motor runs, cylinder is not retracting	Dead or low battery	Load test battery	Charge or replace battery
	Poor ground	Ground battery directly to DC motor	Use jumper cables to jump ground only
	Coil on solenoid valve not activating	Ensure power is getting to coil, check all electrical connections and check for magnetism	Replace coil if you are getting power to the coil but it is not energizing.
		Check ground wire or valve stem. For loose connections or corrosion. (If coil is single wire lead, check the contacting point where solenoid rests on valve stem for corrosion)	
		Loose wire in quick connector or control box	
		Clean contact in hand control with eraser	
	Debris in screen of load holding valve (motor would be running and bypassing over relief valve)	Remove load holding valve. Inspect screen & valve for debris. (DO NOT REMOVE VALVE FOR INSPECTION IF SYSTEM IS UNDER PRESSURE)	Use dipstick on power unit to manually shift the valve. This is accomplished by inserting the dipstick in the nose of the valve and applying pressure. Replace valve if it doesn't shift.
	Debris in flow control valve if present	Remove flow control valve & inspect valve for debris.	Top of valve is threaded, use 1/4-20 bolt to remove flow control valve.
	Directional valve issue	Check for bent valve stem	Replace valve if stem is bent
		Ensure coil is energizing	Double check you are getting power to coil before replacing
		Remove valve and inspect O-rings	Replace O-rings if damaged
		Check cross drilled holes between O-rings of valve for debris	Replace valve if spool is not shifting (for most directional valves the spool will cover half of the cross drilled holes when valve is at its at rest or activated positions)
		Ensure valve is shifting (use dipstick push on valve spool to shift valve. Look through cross drilled holes between O-rings ensuring valve is shifting)	
Relief valve	If relief valve is bypassing check pressure gage to ensure valve is set at proper setting as marked on power unit	Double check with equipment manufacturer insuring the manufacturer did not adjust pressure setting at factory.	
Cylinder	Check to see if there is hydraulic pressure in the lines	If there is no pressure in lines and cylinder will not retract replace or repair cylinder	

TROUBLE SHOOTING

SYMPTOMS	Possible Cause	Correction	Notes
Reservoir overflows when lowering	Low fluid level	Add fluid to reservoir when cylinder is fully retracted	Before running power, unit ensure all air bubbles have dissipated to prevent further aeration of fluid
	Loose inlet	Remove reservoir & tighten or replace inlet tube on pump	
	Reservoir too small for hydraulic system	Consult equipment manufacturer for correct reservoir size	

SYMPTOMS	Possible Cause	Correction	Notes	
Struggles to lift load	Dead or low battery	Load test battery	Charge or replace battery	
	Poor ground	Ground battery directly to DC motor	Use jumper cables to jump ground only	
	Directional valve is not completely shifting	Check for bent valve stem	Replace valve if stem is bent	Replace valve if spool is not shifting (for most directional valves the spool will cover half of the cross drilled holes when valve is at its at rest or activated positions)
		Check cross drilled holes between O-rings of valve for debris	Ensure valve is shifting (use dipstick push on valve spool to shift valve. Look through cross drilled holes between O-rings ensuring valve is shifting)	
	Debris in screen of load holding valve	Remove load holding valve. Inspect screen & valve for debris. (DO NOT REMOVE VALVE FOR INSPECTION IF SYSTEM IS UNDER PRESSURE)	Use dipstick on power unit to manually shift the valve. This is accomplished by inserting the dipstick in the nose of the valve and applying pressure. Replace valve if it doesn't shift.	
	Rust in motor	Bypass start solenoid	If motor doesn't run at a higher RPM after bypassing start solenoid, remove rear cover of motor for quick inspection.	
Worn seals in cylinder	Packing on piston of cylinder could be bad and be wedged against bore of cylinder	Have cylinder tested by certified technician		

SPECIFICATIONS

OVERALL DIMENSIONS

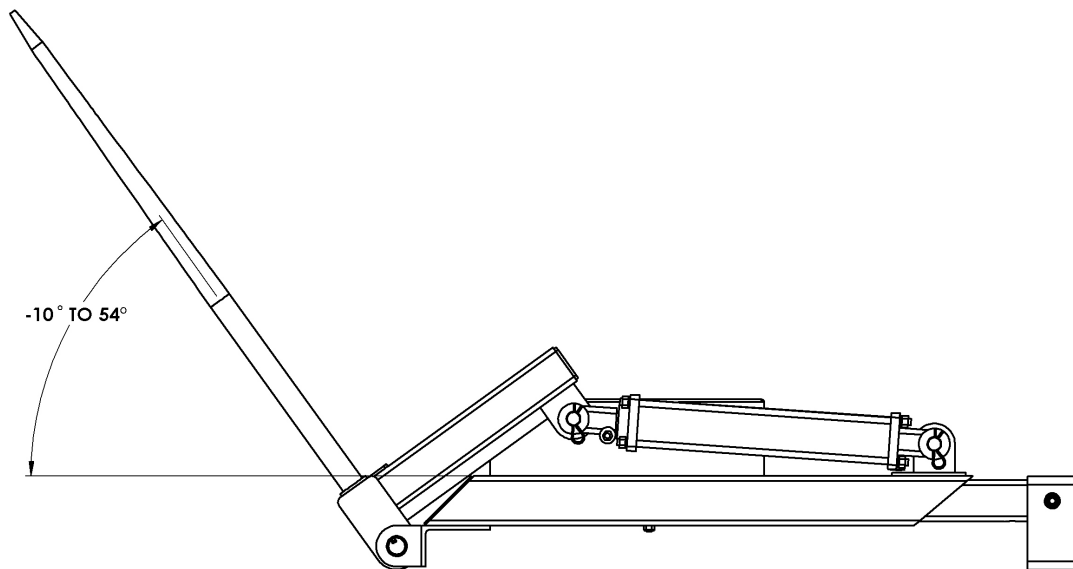
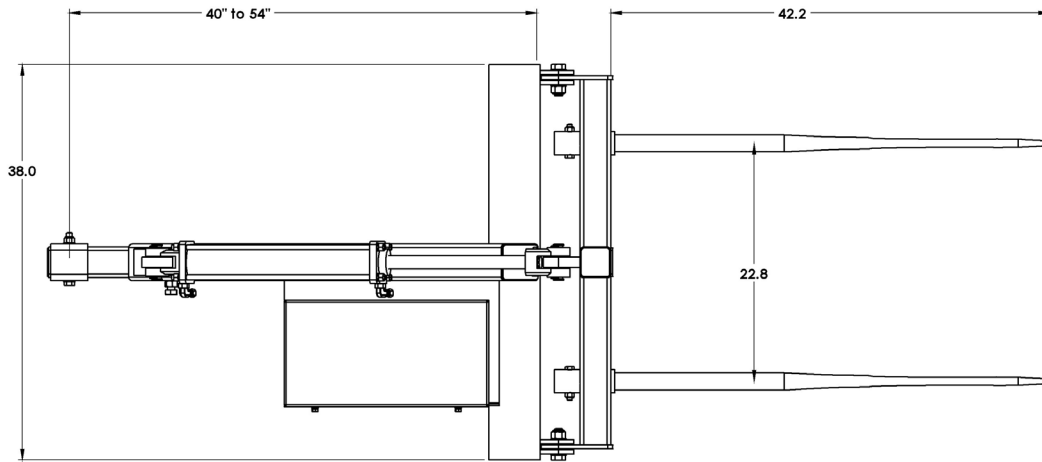

HYDRAULIC CYLINDER

DIAMETER (IN)	STROKE (IN)	LENGTH (IN)	PIN SIZE (IN)
3	16	26	1

HYDRAULIC POWER UNIT

MODEL	VOLTAGE (V)	POWER (KW)	OIL TANK (L)	PRESSURE (PSI)

WARRANTY

IMPORTANT NOTICE

We, the manufacturer, reserve the right to change the product and/ or specifications in this manual without notification. The manual is for information usage only and the pictures and drawings depicted herein are for reference only.

Warranty

AGKNX makes no express warranty for this product except those specifically set forth herein. AGKNX warrants its products to be free from defect in design, material and workmanship for a period of 6 months from original date of purchase, and to be suitable for and to perform in accordance with the use(s) and specifications stated in product materials.

EXCLUSION OF IMPLIED WARRANTIES: AGKNX MAKES NO WARRANTY OF MERCHANTABILITY OF THE GOODS SOLD UNDER THIS AGREEMENT. AGKNX MAKES NO WARRANTY OF FITNESS FOR A PARTICULAR PURPOSE OF THE GOODS SOLD.

Warranty does not cover normal wear, misuse, neglect, abuse, improper maintenance, overload beyond rated capacity, accidents, cosmetic defects, consumables, non-authorized replacement parts or accessories, operation with inadequate supply of hydraulic oil, improper fluid types or unauthorized adjustments.

Warranty Repair and Service

If a defect in a product is discovered and is covered by this warranty, Tool Tuff Direct will have the option to repair, refurbish or replace any warranted item(s), such option to be exercised in AGKNX sole discretion. This warranty inures to the benefit of the original purchaser only, is non-transferable, and has no cash value. Call our customer service department at **303-278-0664** for warranty questions.

Record the information below for future reference.

Model No. _____

Serial No. (found on the power unit tank) _____

Date of Purchase _____

Place of Purchase _____

For Service or Questions:
Call 303-278-0664



REGISTRATION

Acceptance of responsibility:

I (purchaser) have read the Operation Manual and Limited Warranty or someone has read and explained all instructions to me. I understand this warranty does not cover any labor and that all disputes will be settled by binding arbitration. Warranty void if any attempt to repair or replace defective parts has been made by unauthorized personnel. The mark next to each item below confirms my acceptance of responsibility for the use and maintenance of this truck bed bale spear kit. I understand that I alone am responsible for the proper maintenance, care and safe operation of this truckbed bale spear.

- Received, read and understand the Operation Manual
- Understand the safety warnings
- Specifications accepted
- Operations understood
- Maintenance requirements understood

I (purchaser) understand that persons who have not read and understand the operations manual should not be allowed to use the machinery. Children should not operate or be near the equipment. Anyone operating the truck bed bale spear must have read the safety and operations manual. Is this truck bed bale spear used in a business:

No: _____ Yes, business type: _____

Owner / Purchaser Signature: _____

The warranty may be refused if the registration is not legible, completed and signed. It is the responsibility of the purchaser to assure that the registration form is received.

REGISTRATION

WARRANTY VOID IF REGISTRATION IS NOT POST MADE WITHIN 15 DAYS OF PURCHASE.

Mail to:
AGKNX
15000 West 44th Ave, Suite B
Golden, CO 80403

Serial #: _____
Purchase Date: _____
Purchased From: _____
Purchaser: _____
Purchaser's Address: _____
City: _____ State: _____ Zip Code: _____
Phone: _____ Email: _____

Attach a copy of receipt or proof of purchase.

Registration may be completed by scanning the Registration pages and emailing them to:
customerservice@agknx.com

For Service or Questions:
Call 303-278-0664

