



CAR FILLING



DISPENSERS



PUMPS



METERS



NOZZLE METERS



NOZZLES

TURBINOX

FEATURES

- LONG LASTING
- INDUSTRIAL APPLICATION
- STAINLESS STEEL BODY
- VERSATILE

The Piusi TURBINOX is a turbine pulse meter suitable for transferring AdBlue®. Its stainless steel body guarantees a long-lasting resistance and makes this meter perfect for plant installations.

PERFORMANCE

± 1%

ACCURACY

20 BAR

PRESSURE

**UP TO
40 L/MIN**

FLOW RATE

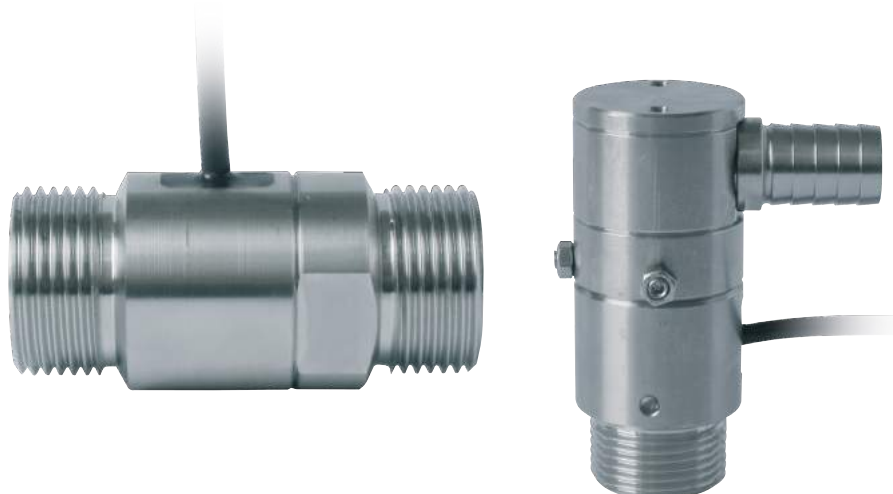

TURBINOX - TURBINOX 90°



PACKAGING

CODE	WEIGHT		PACKAGING		
	KG	LBS	MM	INCH	PCS/BOX
FOO420000A	0,5	1,1	80X80X75	3,1X3,1X3	1
FOO420001A	0,5	1,1	80X80X75	3,1X3,1X3	1
FOO410000	1,2	2,6	225X125X150	8,9X4,9X5,9	1



FILTRATION



FLUID MONITORING



HOSE REELS



ACCESSORIES



MERCHANDISE



AIR



ANTIFREEZE



AdBlue®



BIODIESEL



DIESEL



FOOD



GASOLINE



GREASE



KEROSENE



OIL



WATER



WINDSCREEN

CHARTS

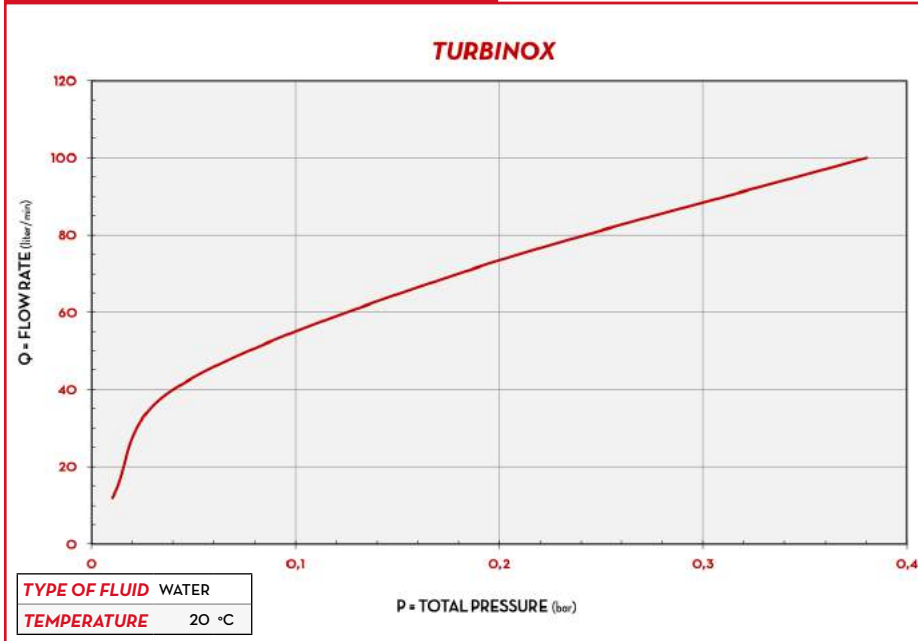

IN THE BOX

- TURBINOX METER
- INSTRUCTION MANUAL

DETAILS



DIMENSIONS

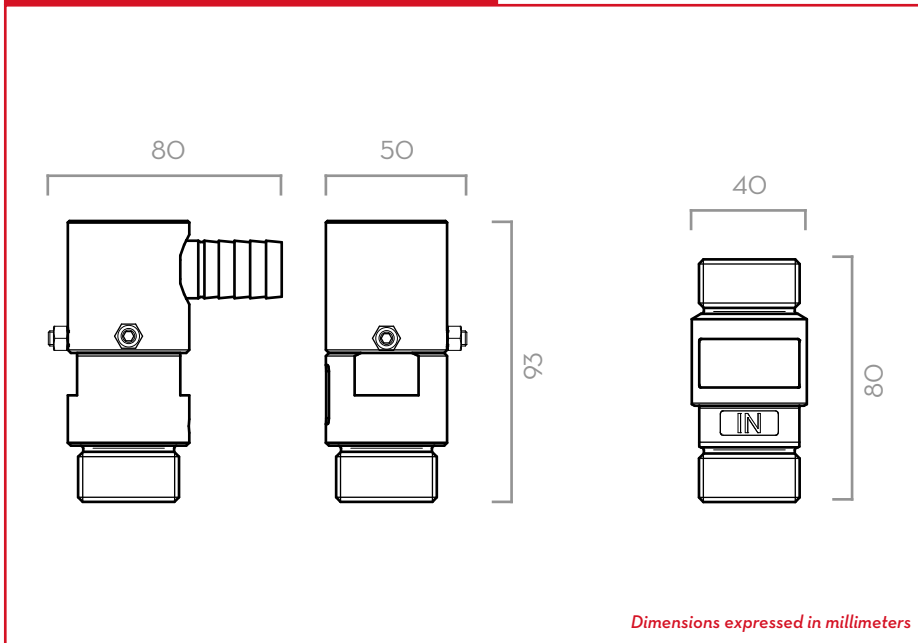

MATERIALS

- BODY: STAINLESS STEEL
- TURBINE: TECHNOPOLYMER

TECHNICAL DATA

CODE	DESCRIPTION	FLUIDS TYPE	FLOW-RATE		PRESSURE		DISPLAY	PULSE OUT (P/L)	
			L/MIN	GPM	BAR	PSI		PULSE VERSION	DISPLAY VERSION
FO042000A	TURBINOX INLINE PULSE METER		10 - 40	2,6-10,6	20	290	NO	88	-
FO042001A	TURBINOX 90° TURBINE PULSE METER		10 - 40	2,6-10,6	20	290	NO	88	-
FO0410000	TURBINOX 90° TURBINE PULSE METER W/DISPLAY UREA		10 - 40	2,6-10,6	20	290	YES	88	1 - 100

TURBINOX