



KITS



PUMPS



METERS



METERED NOZZLES



NOZZLES



WASTE OIL EQUIPMENTS

NEXT/2

FEATURES

- ADJUSTABLE UNIT OF MEASUREMENT
- EASY BATTERIES MAINTENANCE
- AAA STANDARD BATTERY
- SHOCK-ABSORBING PROTECTION
- ON-SITE CALIBRATION

The PIUSI NEXT/2 meter is an oval gear meter suitable for the delivery of low, medium and high viscosity oils. Its particular size allows the meter to count at high flow rates.

PERFORMANCE

UP TO 6-60 L/MIN	MAX 70BAR
FLOW RATE	OPERATING PRESSURE
± 0,5%	0,2%
ACCURACY	REPEATABILITY



NEXT/2



PACKAGING

CODE	WEIGHT		PACKAGING			
	KG	LBS	MM	INCH	PCS/PALLET	PCS/BOX
FOO486150	0,6	1,3	115X160X135	4,5X6,3X5,3		1



FILTRATION



FLUID MONITORING



TANK MONITORING



HOSE REELS



ACCESSORIES



MERCHANDISE



AIR



ANTIFREEZE



AdBlue®



BIODIESEL



DIESEL



FOOD



GASOLINE



GREASE



KEROSENE



OIL



WATER



WINDSCREEN

CHART

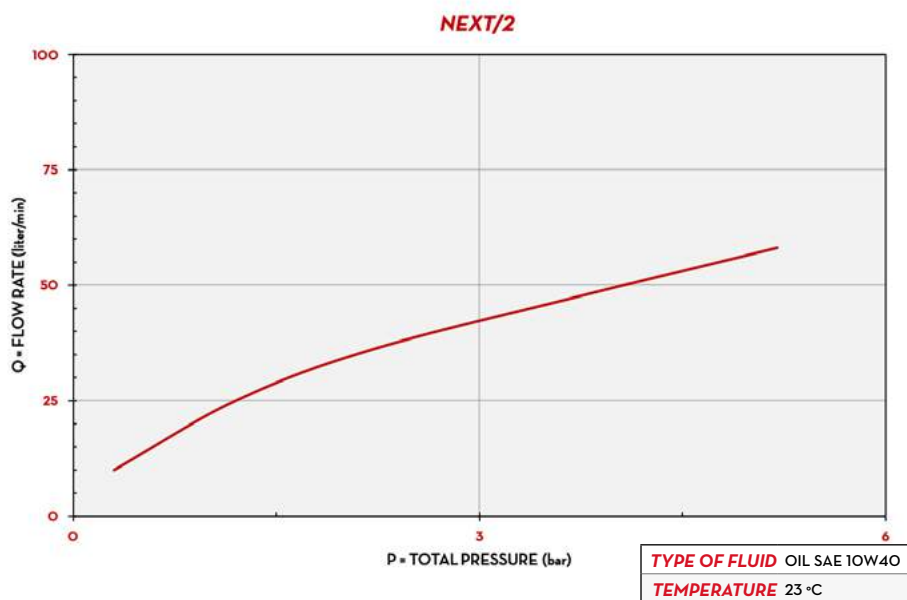

DIMENSIONS

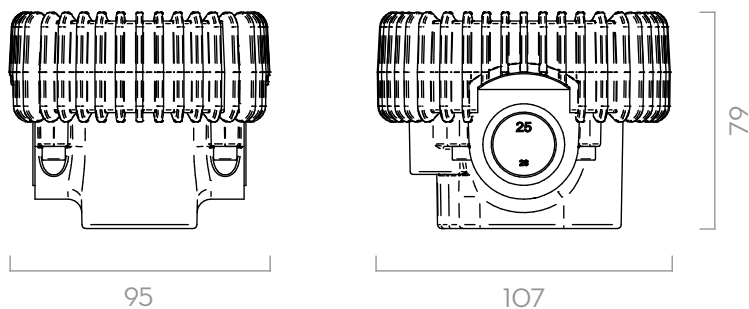

Dimensions expressed in millimeters

IN THE BOX

- NEXT/2 METER
- INSTRUCTION MANUAL

DETAILS



MATERIALS

- BODY: ALLUMINIUM
- GEARS: TECHNOPOLYMER

TECHNICAL DATA

CODE	DESCRIPTION	FLUIDS TYPE	FLOW RATE		WORKING PRESSURE		BATTERY INCLUDED AAA N°2 2X1.5 V	INLET	OUTLET
			L/MIN	GPM	BAR	PSI			
FOO486150	NEXT 2 METER .2" BSP		6 - 60	1,58 - 158	70	994	YES	3/4" BSP	3/4" BSP

NEXT/2