

# *Illustrated Parts Manual*

## **RL255/257/2510**

### **25" Commercial Reel Mower**

Parts for the Original Trimmer Mowers and California Trimmer Mowers (one in the same, really) are interchangeable since 1941. Therefore if you are servicing a 25" commercial Trimmer mower, the parts contained within this book will fit your mower.



# **EVERGREEN**

## **TURF EQUIPMENT**

1028 4<sup>th</sup> Street SW, Bldg A • Auburn, WA 98001 • Phone: (253) 333-3345 • Fax: (253) 414-1293

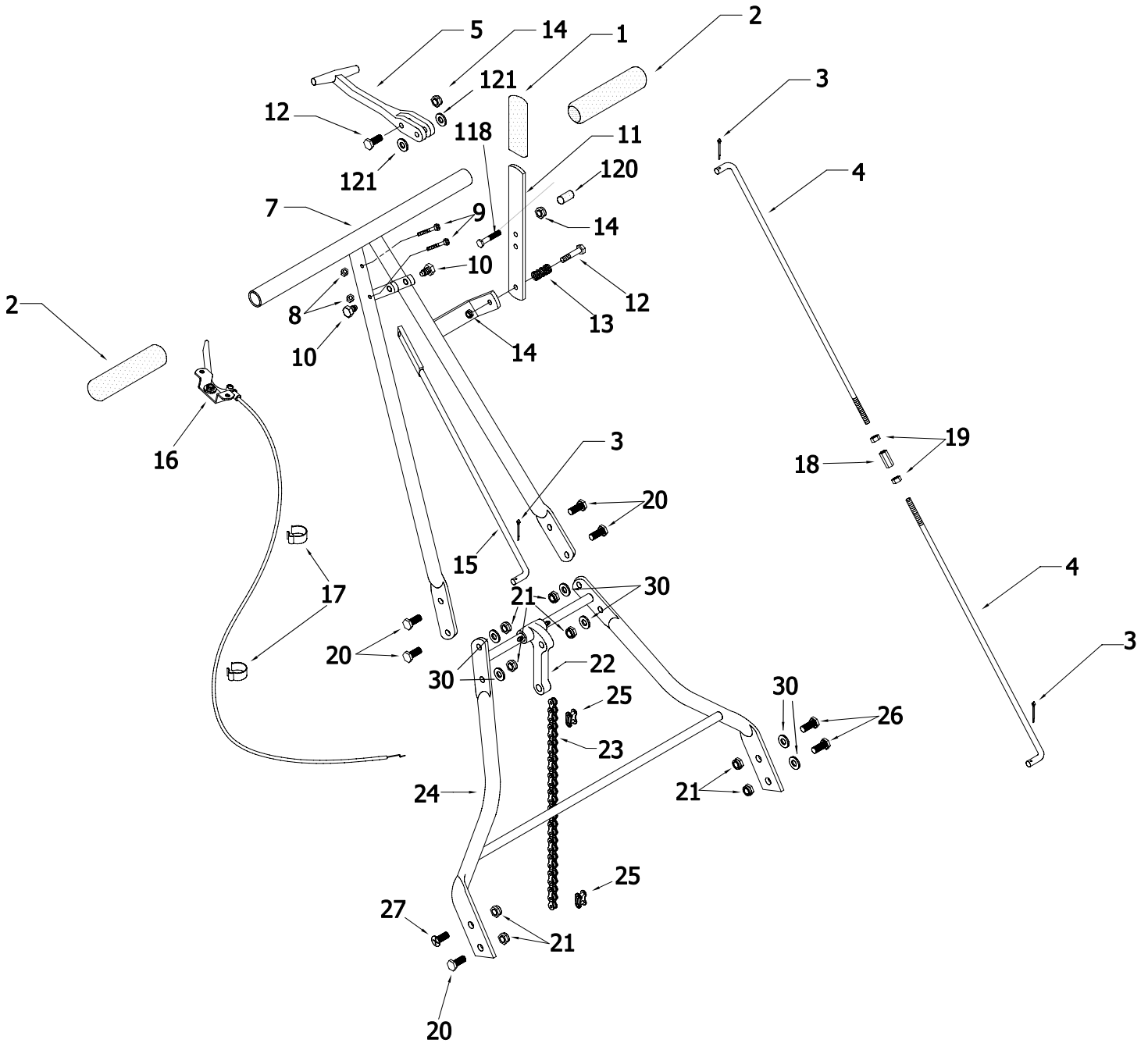

# PARTS INFORMATION

# RL-255/257-GX160

## HANDLE & CONTROLS - FIGURE 1

ITEM	PART NUMBER	DESCRIPTION	QTY	COMMENTS
1	H0423	GRIP, FLAT	1	
2	25502	GRIP, HANDLE 20/25"	2	
3	931	PIN, COTTER	3	
4	25507	ROD, CLUTCH	2	
TBD	25507-HD	HEAVY-DUTY CLUTCH ROD KIT, 3-PIECE	1	Will not flex, bend or brake
5	H0503	HANDLE, ROLLER LIFT	1	
7	25501ST-12	HANDLE, TOP, 12" WIDE	1	Grips not included
7	25501ST-16	HANDLE, TOP, 16" WIDE	1	Grips not included
8	919	NUT, 10-32	2	
9	901	BOLT, 10-32 x 1 1/4 PH PAN	2	
10	H0504	BOLT, TRUNNION, 5/16-18	2	
11	25515	HANDLE, CLUTCH	1	
12	905	SCREW, 1/4-28 x 1 1/4 HEX CAP	2	
13	H0425	SPRING CLUTCH & HANDLE HEIGHT	1	
14	944	NUT, 1/4-28 THIN NYLOCK	3	
15	25510	ROD, LIFT	1	
16	H0508	THROTTLE LEVER ASSY, 20-25"	1	
17	947	SPRING, CLIP	2	Holds throttle cable to handle (pipe)
18	951	NUT, 5/16-24 COUPLING	1	Adjusting nut for clutch rods
19	921	NUT, 5/16-24 FINISH	2	
20	909	BOLT, 5/16-24 x 3/4" HX G5 Z	5	
21	922	NUT, 5/15-24 THIN NYLOCK	8	
22	25512	TOGGLE	1	Not replaceable on later models
23	25609	CHAIN, ROLLER LIFT 20-25", 40x32	1	Fits 20" and 25" commercial units
24	25501SB	HANDLE, BOTTOM, 25"	1	25" only
25	25806	LINK, CONN #40	2	
26	907	BOLT, 5/16-24 x 5/8, HEX G5 Z	2	
27	941	SCREW, 5/16-24 x 3/4 FLAT PHILLIPS	1	
30	928	WASHER, 5/16 SAE FLAT Z	6	
118	H0933	BOLT, HANDLE STOPPER	1	
120	H0913	CAP, PLASTIC (CLUTCH ROD STOPPER)	1	
121	25906	WASHER, TRUNNION BOLT	2	

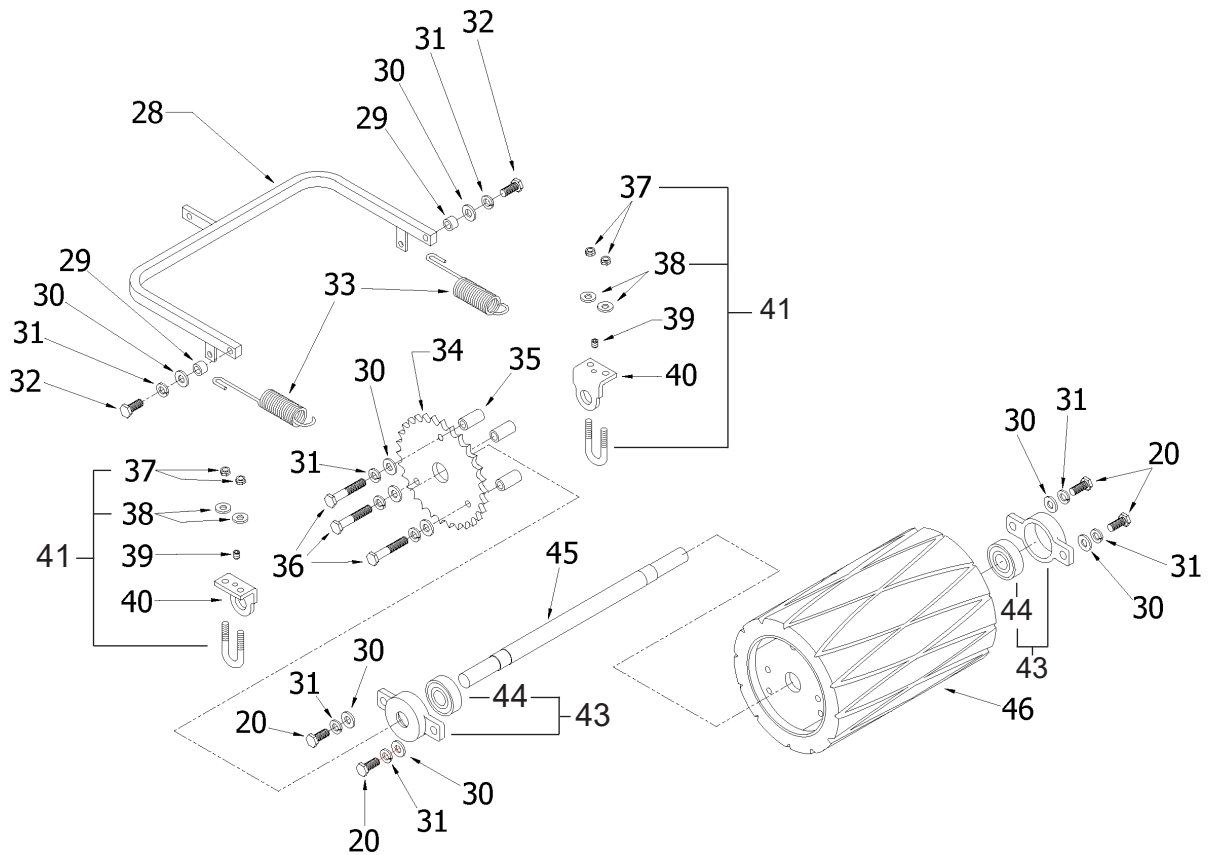

ITEM	PART NUMBER	DESCRIPTION	QTY	COMMENTS
20	909	BOLT, 5/16-24 x 3/4" HX G5 Z	4	
28	25607	ROLLER YOKE, 20/25"	1	
29	H0608	BUSHING, YOKE	2	
30	928	WASHER, 5/16 SAE FLAT Z	9	
31	927	WASHER, 5/16 SPLIT LOCK	9	
32	910	BOLT, 5/16-24 x 7/8 HX G5 Z	2	
33	H0610	SPRING, ROLLER	2	
34	25605	SPROCKET, ROLLER, LARGE, 30T	1	
35	25606	SPACER, SPROCKET	3	
36	913	BOLT, 5/16-24 x 1 3/4 HX G5 Z	3	
37	920	NUT, NYLOCK, THICK, 1/4-28	4	
38	948	WASHER, 1/4 SAE FLAT Z	4	
39	934	SET SCREW, 1/4-20 x 1/4 SOC SET	2	
40	H0604	CLAMP, ROLLER	2	
41	603	U-BOLT, 1/4-28	2	Includes #37, #38, not #39 or #40
43	25304	HOLDER, BEARING 2-EAR W/NSK BRG	2	
44	25324	BEARING, SEALED	2	
45	25602	SHAFT, ROLLER 20/25"	1	
46	25601	ROLLER 20/25"	1	

## Engine Mounting Hardware

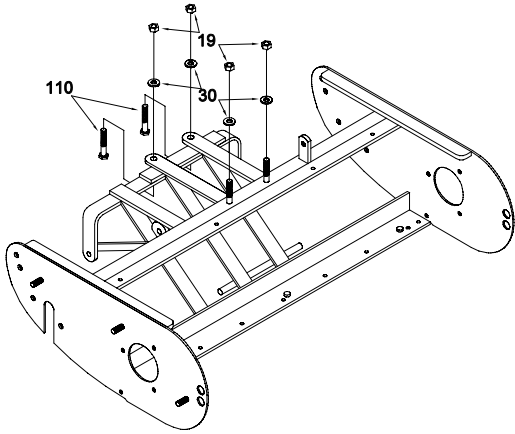

Older mowers without chain tensioners can use engine shims to reduce slack in the chain.

Order #

#25811 Engine Shim, Thin (1/8")

#25812 Engine Shim, Thick (3/16")

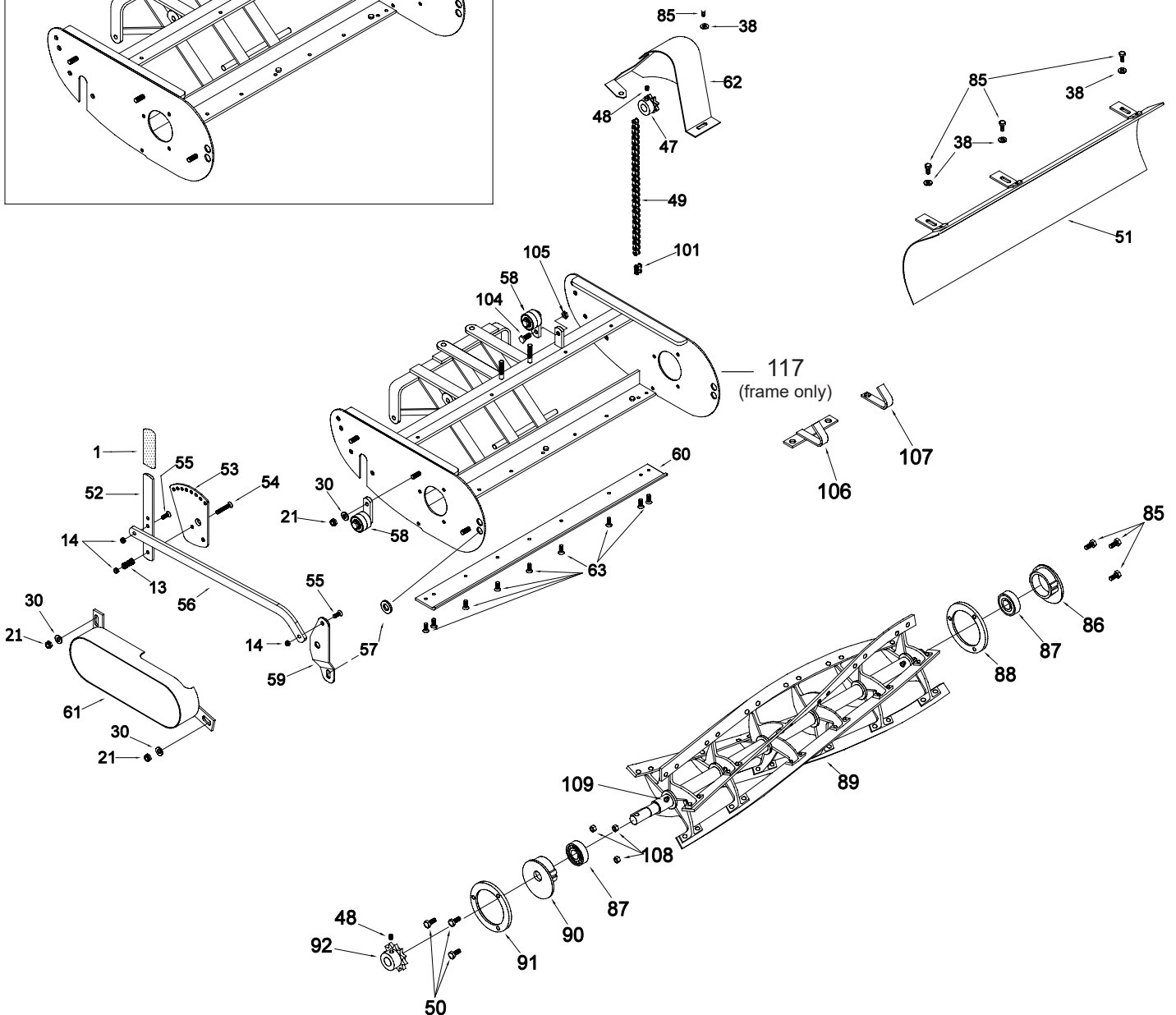

# PARTS INFORMATION

# RL-255/257-GX160

FRAME, BED KNIFE, GUARDS, BLADE • FIGURE 3

ITEM	PART NUMBER	DESCRIPTION	QTY	COMMENTS
1	H0423	GRIP, FLAT	1	
13	H0425	SPRING CLUTCH & HANDLE HEIGHT	1	
14	944	NUT, 1/4-28 THIN NYLOCK	3	
19	921	NUT, 5/16-24 FINISH	4	
21	922	NUT, 5/16-24 THIN NYLOCK	3	
30	928	WASHER, 5/16 SAE FLAT Z	7	
38	948	WASHER, 1/4 SAE FLAT Z	4	
47	25824	SPROCKET, ENGINE (STD), 8T x 3/4	1	3.51 MPH w-8 tooth roller sprocket
47	25817	SPROCKET, ENGINE (ALT), 9T x 3/4	1	3.95 MPH w-8 tooth roller sprocket
47	25819	SPROCKET, ENGINE (ALT), 10T X 3/4	1	4.39 MPH w-8 tooth roller sprocket
47	25821	SPROCKET, ENGINE (ALT), 11T x 3/4	1	4.83 MPH w-8 tooth roller sprocket
48	935	SET SCREW	2	Order #935HD for crankshaft keyway
49	25407	CHAIN, ENGINE, 20-25", 40x56	1	Fits 20" and 25" commercial units
50	904	BOLT, 1/4-28 x 5/8 HX G5 Z	3	
51	25402	SHIELD, GRASS	1	25" only
52	H0422	HANDLE, HEIGHT ADJUSTMENT	1	
53	H0421	PLATE, HEIGHT ADJUSTMENT	1	
54	942	SCREW, 1/4-28 X 1-1/2 PHIL FL	1	
55	943	BOLT, 1/4-28 x 3/4 FL SOC P	2	
56	H0426N	CONNECTOR, CURVED	1	For straight bar order H0426
57	930	WASHER, 1/2 SAE FLAT, ZINC	1	Placed between frame and bracket
58	25825	TENSIONER, CHAIN	2	
59	H0424	BRACKET, FRONT	1	
60	25401	BED KNIFE, 25"	1	
61	H0410	GUARD, REEL CHAIN	1	
62	25408	GUARD, ENGINE CHAIN	1	
63	902	SCREW, CUTTER BAR	9	
85	903	BOLT, 1/4-28 x 1/2 HX G5 Z	7	
86	25203	BEARING HOLDER, REEL, LEFT	1	
87	H0202	BEARING, REEL, ALL	2	Sealed on inside
88	25208	CLAMP RING, THREADED 20/25"	1	
89	25201-5	BLADE REEL, 25" x 5 BLADE	1	25" only
89	25201-7	BLADE REEL, 25" x 7 BLADE	1	25" only
89	25201-10	BLADE REEL, 25" x 10 BLADE	1	25" only
90	25204	BEARING HOLDER, REEL, RIGHT	1	
91	25209	CLAMP RING, UNTHREADED 20/25"	1	
92	H0820	SPROCKET, REEL, 11T x 5/8	1	
101	25806	LINK, CONNECTOR #40	1	#40 half link p/n 25807
104	100-002	BOLT, 5/16-18 x 3/4 HX G5 Z	1	
105	130-002	NUT, LOCK, 5/16-18	1	
106	25803H	HOOK, CATCHER, 20/25", HONDA	1	
107	H0803	HOOK, CATCHER, 20/25", BRIGGS	1	
108	920	NUT, 1/4-28	3	
109	H0207	FITTING, GREASE, M6 x 1	2	
110	914	BOLT, ENGINE MOUNTING	2	
117	25902	FRAME, 25"	1	Bare frame, painted dark green
N/A	25911	ENGINE SHIM (THIN)	1	Not shown in illustration
N/A	25912	ENGINE SHIM (THICK)	1	Not shown in illustration

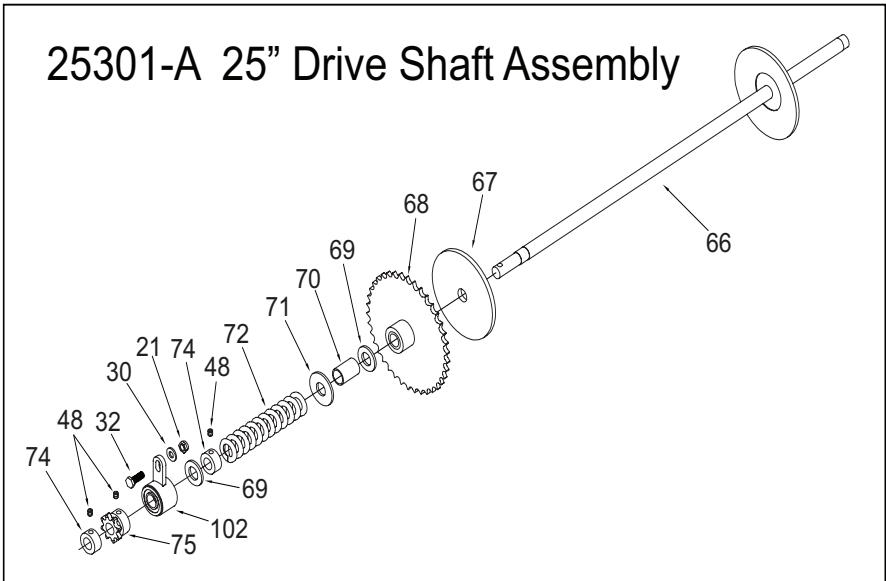
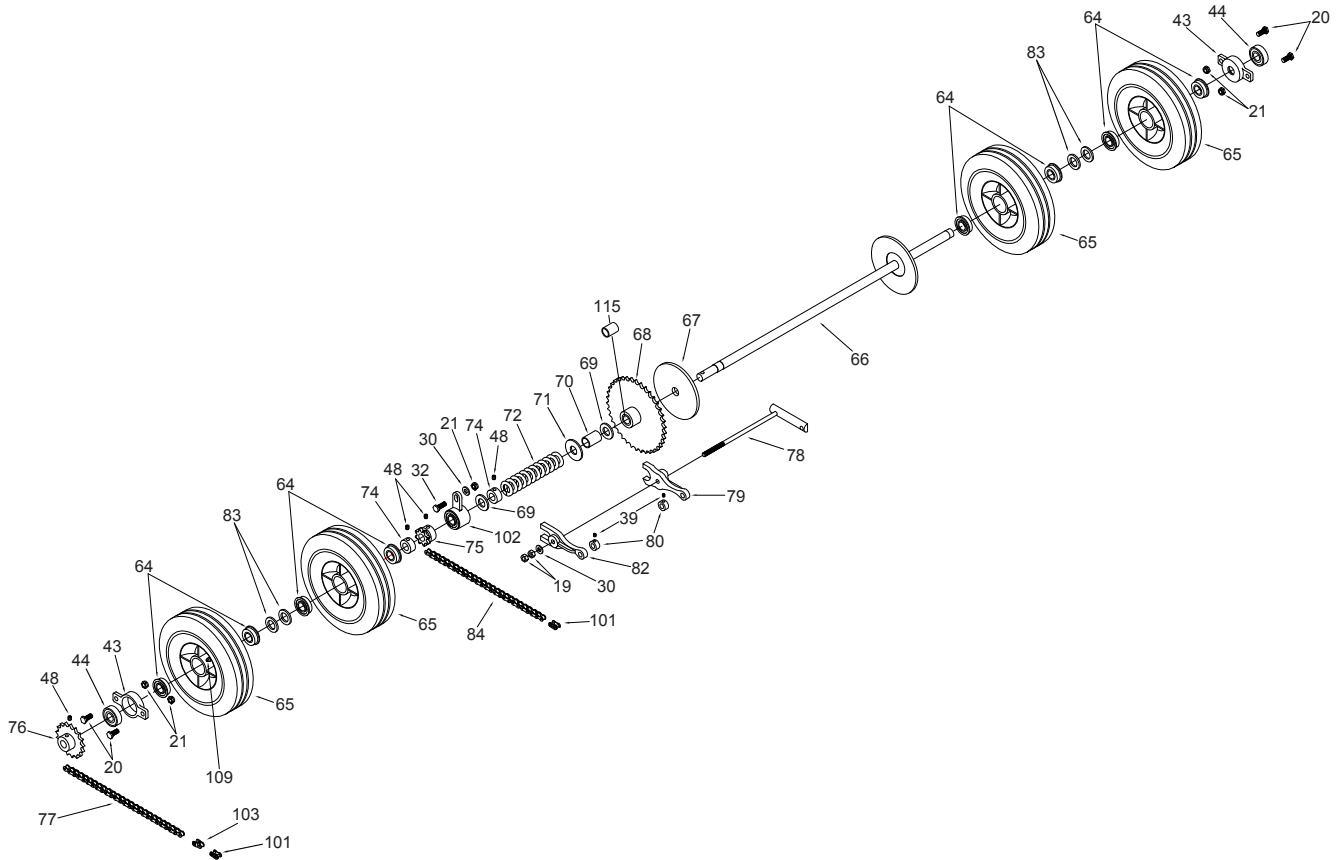

# PARTS INFORMATION

# RL-255/257-GX160

## DRIVE SHAFT, WHEELS, REEL, CHAIN • FIGURE 4

ITEM	PART NUMBER	DESCRIPTION	QTY	COMMENTS
19	921	NUT, 5/16-24 FINISH	2	
20	909	BOLT, 5/16-24 x 3/4 HX G5 Z	4	
21	922	NUT, 5/15-24 THIN NYLOCK	5	
30	928	WASHER, 5/16 SAE FLAT Z	2	
32	910	BOLT, 5/16-24 x 7/8 HX G5 Z	1	
39	934	SET SCREW, 1/4-20 x 1/4	2	
43	25304	BEARING HOLDER	2	Includes 25324 bearing (installed)
44	25324	BEARING, SEALED	2	
48	935	SET SCREW	4	
64	25307	BEARING, WHEEL 20/25"	10	Also used in 25322 Steady Rest (2)
65	25306	TIRE ASSY W/BEARING, 20/25"	4	
66	25301	SHAFT, DRIVE, 25"	1	25" only
67	25311	LINING, CLUTCH	1	
68	25318	SPROCKET, DRIVE, 39T W/OILITE	1	
69	25312	WASHER SMALL HARD	2	
70	25314	SPACER, CLUTCH	1	
71	25313	WASHER LARGE HARD	1	
72	25316	SPRING, CLUTCH	1	
74	25315	COLLAR, SET, 20/25"	2	
75	25823	SPROCKET, ROLLER, SMALL (STD) 8T x 11/16	1	
75	25317	SPROCKET, ROLLER, SMALL (ALT) 9T x 11/16	1	
76	H0310	SPROCKET, REEL, 17T x 5/8	1	
77	25206	CHAIN, REEL, 20-25", 40x46	1	Fits 20" and 25" commercial units
78	25321	BOLT, ADJUSTING	1	
79	25320	FORK, LARGE	1	
80	25419	COLLAR SET, 3/8	2	
82	25319	FORK, SMALL	1	
83	25323	SPACER, WHEEL	4	
84	25611	CHAIN, ROLLER, 20-25", 40x38	1	Fits 20" and 25" commercial units
101	25806	LINK, CONNECTOR #40	2	
102	25322	REST, STEADY	1	
103	25807	LINK, HALF #40	1	
109	H0207	FITTING, GREASE, M6 x 1	4	
115	25302	OILITE BUSHING	1	



# PARTS INFORMATION

# RL-255/257-GX160

## CASTERS, TIE ROD • FIGURE 5

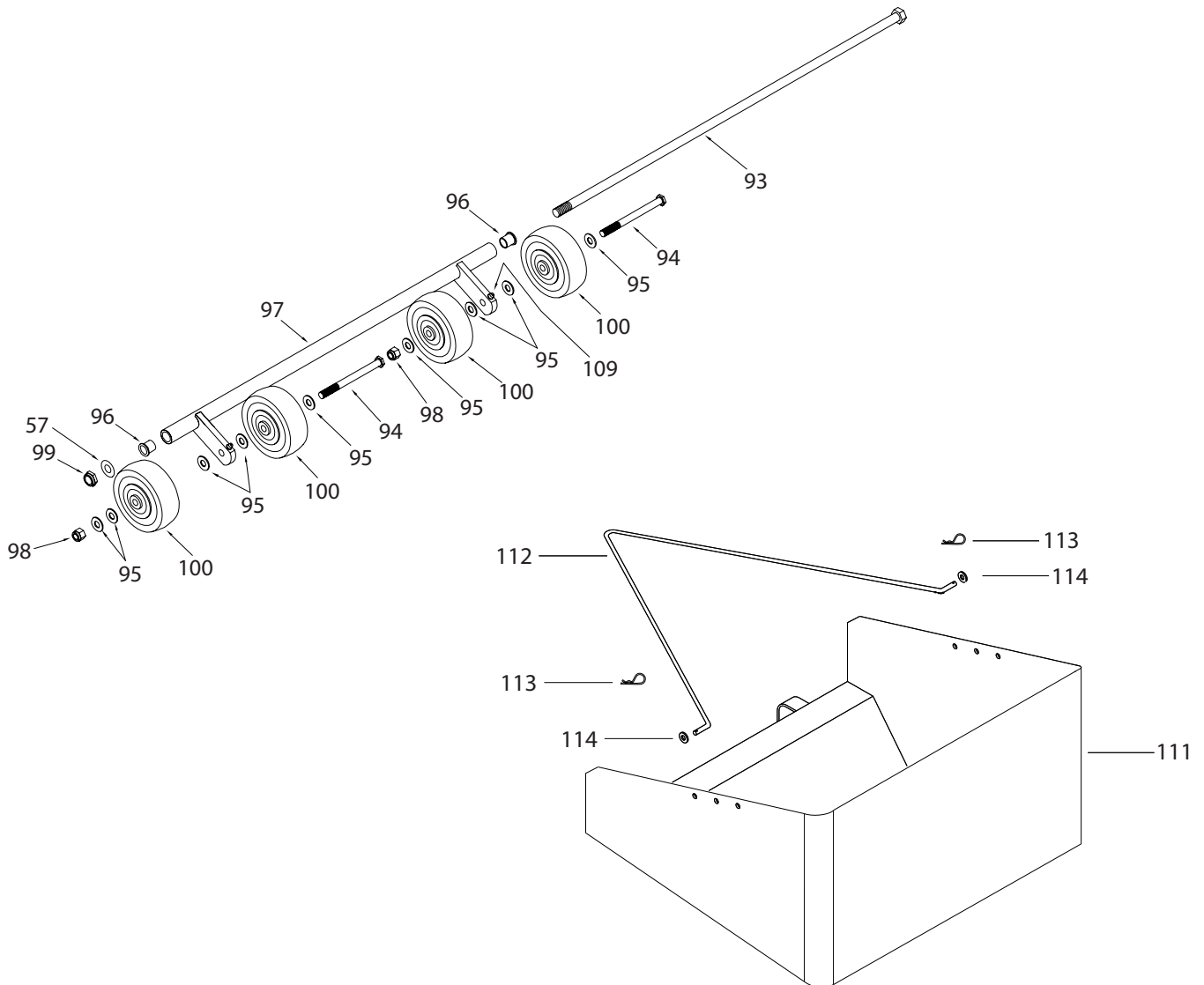

ITEM	PART NUMBER	DESCRIPTION	QTY	COMMENTS
57	930	WASHER, 1/2 SAE FLAT, ZINC	1	Placed between frame and bracket, Fig 3
93	25403	ROD, TIE 25"	1	25" only
94	918	BOLT, 3/8-16 x 5 HEX CAP GR5	2	25" only
95	929	WASHER, 3/8 SAE FLAT Z	9	
96	H0106	BUSHING, CASTER BAR	2	
TBD	970	SLEEVE, CASTER (12.5mm O.D.)	4	Not shown in illustration
97	25101	BRACKET, CASTER 25"	1	25" only, includes zerck fittings
98	908	NUT, 3/8-16 NYLOCK Z	2	
99	924	NUT, 1/2-20 NTE NYLON Z	1	
100	25102-4	CASTER SET (4)	1	Set of 4, plastic
100	25102-4D	CASTER SET, DARNELL (4)	1	Set of 4, rubber (see Figure 8)
109	H0207	FITTING, GREASE, M6 x 1	2	Grease fittings used on earlier models
111	25801	CATCHER ASSY, W/BAIL 25"	1	Plastic catcher, includes #112, #113, #114
112	H0802	BAIL, GRASS CATCHER	1	
113	960	PIN, CLEVIS	2	
114	948	WASHER, 1/4 SAE FLAT Z	2	



### **FR-25 Front Roller, 25"**

The FR-25 front roller replaces the caster bar and casters on your 25" Cal Trimmer mower. There are several advantages. First, this adds a little weight to the front of the mower which is desirable for rougher yards. It also makes the blade cut at the highest contour of the yard and prevents the casters from dipping into flower beds. Finally, you get the stripe in the lawn because it lays the grain of the grass in the same direction that you are mowing. The height adjustment and level of height is the same as the original caster wheels.



### #H0907 Backlapping Kit

Backlapping does not replace the need to grind your reel and bed knife, especially if you have dents or other kinds of blade damage. However, if your blades are in good shape and you want to re-establish the surfaces of the bed knife to reel orientation, this is a good solution. It requires some patience but good instructions are included. The kit also includes a drill adapter, a 10 ounce container of #80 back lapping compound, a replacement sprocket (#H0820) and a durable paint brush. To summarize, backlapping is to run the blades backwards after applying grinding compound. This requires some grinding, then adjusting, more grinding, then adjusting but once you are done you can cut a very thin piece of paper which is the goal.

**P/N 25102-4 CASTER SET, DARNELL (4 casters)**



Optional Darnell casters provide a smooth yet durable / long lasting ride for your California Trimmer mower.

Decal Set, Order #25900



#25907



## P/N 980 - SPRING COMPRESSOR TOOL

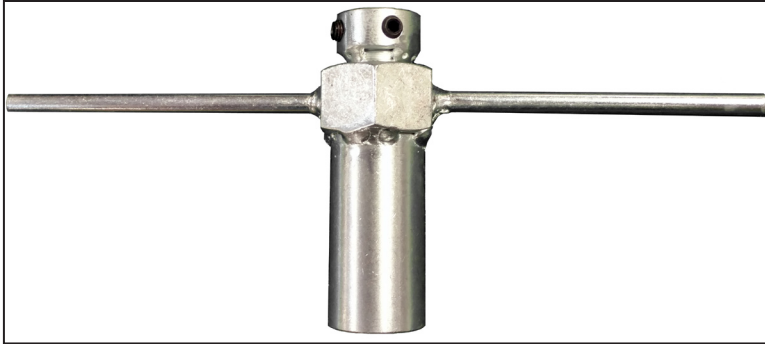

This tool is used for compressing the clutch spring when the installing it on to the drive shaft.

**STEP 1:**

Once all of the components are in place on the drive shaft: clutch lining, sprocket, bushing, washers, spring and collar, place the tool on to the shaft against the collar next to the spring.

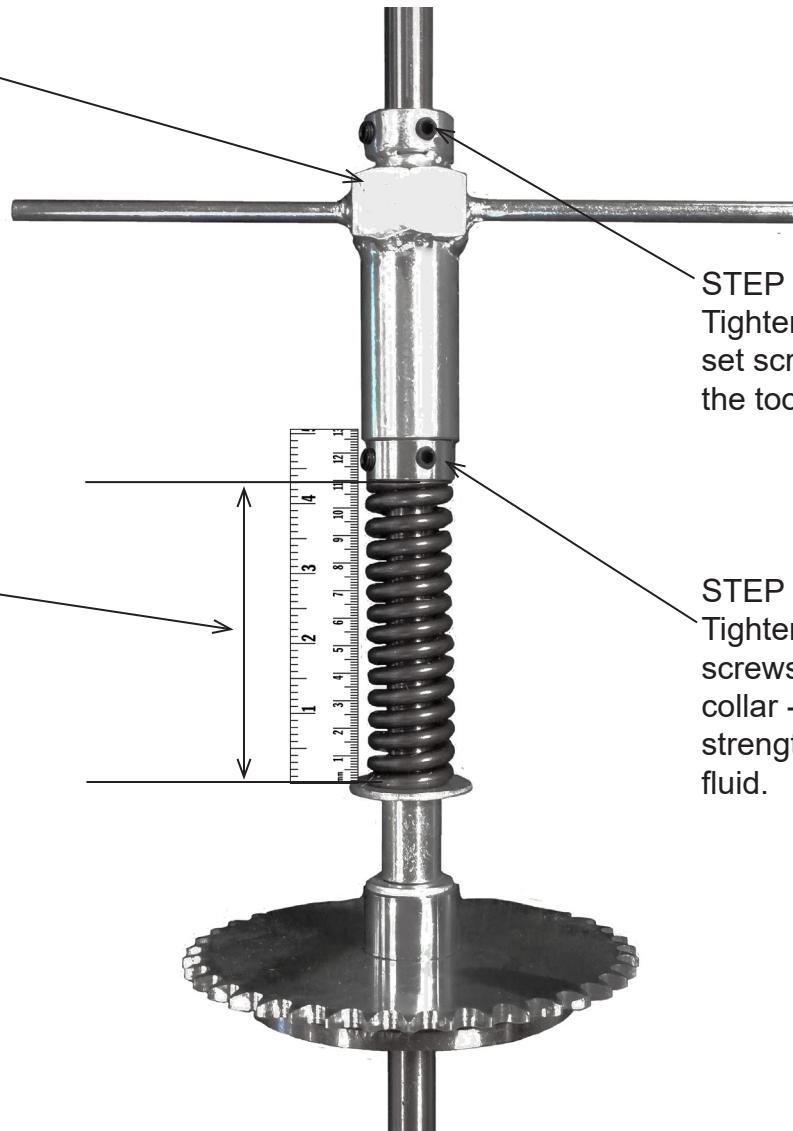
**STEP 2:**

Tighten the collar set screws to secure the tool in place.

**STEP 3:**

Rotate the tool clockwise to begin compressing the spring and continue until it has reached a length of: 4-3/8" (4.375 in. / 111.125 mm).

**STEP 4:**

Tighten the set screws in the collar - use medium strength thread lock fluid.

**STEP 5:**

Loosen the set screws and remove the tool.