

n°	Cod.	Description	Qt.	Dis.	Kg
1	400715/1	STOP ROD 4S	1	12252	3.59
2	5011613	SCREW TPSCEI M16x30	1		0.07
3	400715	STOP ROD - S	1	12620	2.56
4	400292	STOPPER SET	2	12653	0.53
5	5330001	HANDLE	2	-	0.29

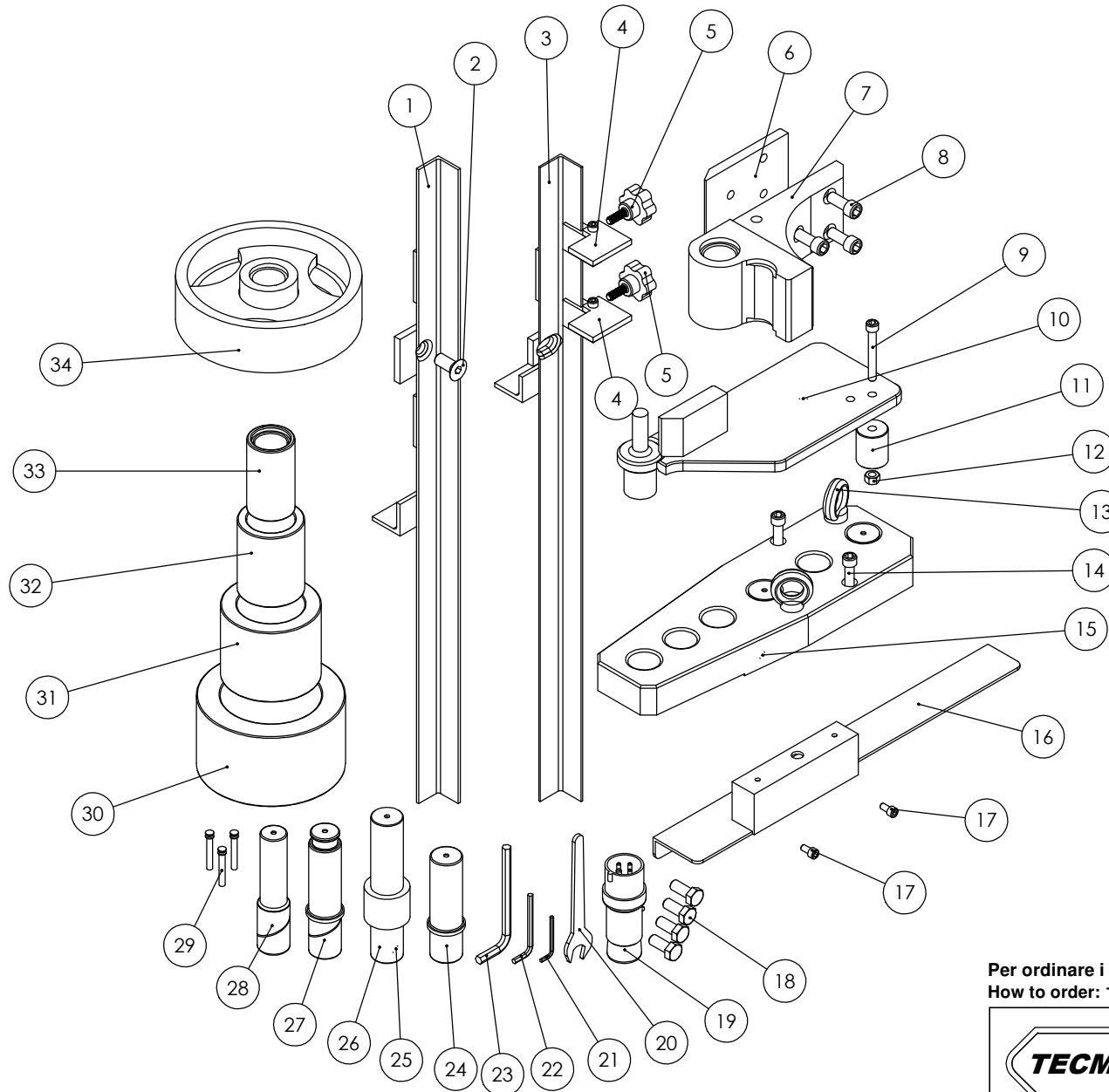

n°	Cod.	Description	Qt.	Dis.	Kg
6	400913	SQUARE PLATE	1	11869	1.47
7	400780	BENDING SQUARE	1	11070	12.66
8	5011410	SCREW TCE M14x35	3		0.07
9	5011041	SCREW TCE M10x80	1		0.06
10	400708	STIRRUP TOOL	1	12242	8.2
11	400706	FIXING PIN FOR STIRRUP TOOLING	1	11901	0.49
12	5021001	NUT M10	1		0.01
13	5011403	EYEBOLT M14	2		0.24
14	5011223	SCREW TCE M12x55	2		0.06
15	400789	COMPLETE ARM	1	-	23.8
16	400966	EXTENCION PROTECTION	1	12365	2.68
17	5010807	SCREW TCE M8x16	2		0.01
18	5011406	SCREW TE M14x35	4		0.07
19	5350082	PLUG	1		0.2
20	5052201	WRENCH 22	1		0.15
21	5050401	HEX KEY 4	1		0.01
22	5050601	HEX KEY 6	1		0.03
23	5051001	HEX KEY 10	1		0.14
24	400707	BENDING PIN Ø42	3	11328	1.70
25	400792	PERNO SLITTE CON BRACCIO (S)	1	11004	2.86
26	400792	PERNO SLITTE CON BRACCIO (4S)	2	11004	2.86
27	400930	BENDING PIN Ø42	1	11640	1.98
28	400763	BENDING PIN Ø35	1	11662	1.58
29	400775	INVERSION PIN 50	3	11724	0.02
30	400712	BENDING BUSH Ø192	1	11375	13.53
31	400711	BENDING BUSH Ø130	1	11665	6.30
32	400710	BENDING BUSH Ø87	2	11664	2.50
33	400713	BENDING BUSH Ø62	4	11663	1.37
34	400-U070	BENDING BUSH Ø240	1	11496	10.91
34	400-U071	BENDING BUSH Ø270	1	11497	12.6
34	400-U072	BENDING BUSH Ø300	1	11498	13.1
34	400-U073	BENDING BUSH Ø328	1	11499	18.8
34	400-U074	BENDING BUSH Ø365	1	11500	21.6
34	400-U085	BENDING BUSH Ø380	1	11501	23.5
34	400-U075	BENDING BUSH Ø400	1	10399	26.1
34	400-U082	BENDING BUSH Ø450	1	10401	29.1

Per ordinare i ricambi riferire: 1. Modello macchina 2. Disegno 3. Codice articolo
 How to order: 1. Machine model 2. Dis. number 3. Code number



Accessori **PF 48 -S-4S**

Dis. **13616**
 Data: **26.11.19**